

# E10

EN

## Powerful and connected, for first-class sterilisation



**Euronda**<sup>®</sup>  
Pro System



*Superior products, quality and service.*  
[WWW.LSRHEALTHCARE.COM.AU](http://WWW.LSRHEALTHCARE.COM.AU)

# E10

## Powerful and connected, for first-class sterilisation

- |    |  |    |   |
|----|--|----|---|
| 4  | <b>E10</b><br>Powerful and connected,<br>for first-class sterilisation         | 18 | <b>Accessories</b><br>Starter kit<br>Tests<br>Optional tray holders   |
| 6  | <b>Performance</b><br>The best Euronda sterilization,<br>how you want it       | 20 | <b>Traceability and retrieving</b><br>Print Set 1<br>Print Set 2<br>Print Set 3<br>E-WiFi<br>E-Data & E-Memory software |
| 8  | <b>Design</b><br>A new dimension<br>in aesthetic appeal                        | 21 | <b>Water treatment systems</b><br>Aquaosmo<br>Aquafilter 1 to 1<br>Aquadist<br>Aquadbox                                 |
| 10 | <b>Innovation</b><br>Technology at people's service                            | 24 | <b>Sterilisation cycles<br/>and personal functions</b>  |
| 12 | <b>Traceability</b><br>A new comprehensive<br>traceability system              | 26 | <b>Technical data and<br/>technical specifications</b>  |
| 14 | <b>Ergonomics</b><br>Total harmony between operator,<br>device and environment |    |   |
| 16 | <b>Safety</b><br>Guaranteed quality<br>throughout its working life             |    |   |

# Euronda Pro System

## Products, Process, Protection



### Cleaning



**Thermal  
disinfection**

Eurosafe 60



**Ultrasonic  
washing**

Eurosonic® 4D  
Eurosonic® 3D  
Eurosonic® Energy  
Eurosonic® Micro

### Packing



**Thermosealing**

Euromatic®  
Euroseal® Valida  
Euroseal® Infinity  
Euroseal®  
Euroseal® 2001 Plus



**Sterilization  
rolls**



**Euroseal®  
Check**

Euronda Pro System is a Total Protection System for clinics that has been developed to ensure the safety of staff, patients, instruments and working environments. The steps of the sterilization process - from collection to storage - can be successful only if carried out properly.

Thanks to the Pro System line, it is possible to implement a cutting-edge, effective and efficient protocol that can be followed on a regular basis and increase the safety of a practice while optimizing its resources.



## Sterilization



### Autoclaves

E10  
EXL  
E9  
E8



### Tests



### Traceability / Retrieving



### Water treatment

Aquaosmo  
Aquafilter 1 to 1  
Aquadist  
Aquabox

# E10

Powerful and connected,  
for first-class sterilisation



After years of research, we have developed an autoclave that combines all of the most important characteristics for clinics worldwide: performance, efficiency, functionality and design. E10 offers better performance in less time. It guarantees exceptional drying and minimizes water and energy consumption. It is not only attractive and quiet (< 50 dB) but also intelligent: innovative technology makes E10 a simple, intuitive autoclave that can cater to the everyday needs of every clinic.



### **Performance**

The top Euronda sterilization system is powerful, it guarantees excellent drying and it is eco-friendly.



### **Innovation**

The new E-Touch, E-Light, E-Timer, E-Help and E-Backup systems put technology at people's service.



### **Design**

E10's sophisticated, contemporary design brings aesthetic to a new stage.



### **Ergonomics**

Increasingly user-friendly, with total harmony between the operator, the device and the working environment.



### **Traceability**

The standard connectivity solutions and the print set options offer comprehensive, expandable traceability.



### **Safety**

New systems guarantee exceptional sterilization quality at all times, from installation to maintenance.

A more powerful vacuum pump, a new instant steam generator and an optimized drying cycle make E10 the best performing Euronda sterilizer ever.



# Performance

## The best Euronda sterilization, how you want it



### Best ever performance

Best ever performance: The vacuum pump is twice as powerful as the one in E9 and E8 autoclaves and the drying cycle is faster, making E10 the best performing Euronda sterilizer ever. The new steam generator instantly produces the steam for the sterilization chamber, optimizing the water consumption in accordance with the load, making further cuts to the sterilization time and actually improving the quality of the steam generated.



### Customization

First and foremost, E10 is a Class B autoclave that can run five different type B cycles (121°C, 134°C, 134°C Prion, 134°C Rapid and 134°C Rapid Prion) in full compliance with EN 13060 standard, as well as three test cycles (Vacuum, Helix, and Bowie and Dick). In addition, thanks to the password-activated Personal functions, it is also possible to run Light cycles (type N cycles - N134 and N121) and Light & Stock cycles (type S cycles - S134 and S121).



### Eco-Friendly

Fast and efficient at the same time. The Euronda Pro System technology assesses the actual size of each load and adapts the sterilization settings to guarantee savings in terms of water, energy and time.



E10's polished, contemporary design is so attractive that you can proudly put it on display. A unique touch is added by the front of the device, which comes in an anthracite tone and takes autoclave aesthetics to a new level with its bold style. The 4" colour touch-screen display and the innovative coloured LEDs of the E-Light system give it a distinctive splash of colour. Every last detail of E10 was conceived to make it attractive and practical at the same time.

**Euronda**  
Pro System

**E10**



# Design

## A new dimension in aesthetic appeal



### + **Sophisticated**

Solid, compact forms come together in a sophisticated, contemporary design with an anthracite front that adds a bold touch. It is so attractive that you can proudly put it on display.

### + **Futuristic**

E10 has a futuristic feel thanks to the stunning colour on the cutting-edge 4" touch-screen display and the LED lighting system in the handle compartment.

### + **Practical design**

Even the most functional features of E10 are designed to be not only attractive but also practical and effective.

# Innovation

## Technology at people's service



### E-Touch

Users can instantly take control thanks to the extremely user-friendly, cutting-edge 4" colour touch screen display, which features a new set of clear, simple icons. The user interface has been specially designed to make everyday tasks faster and more efficient for the operator.



### E-Help

This innovative guidance system helps operators to choose the right cycle for the instruments that they want to sterilize. Consequently, assistants can rest assured that they are selecting the most suitable cycle and there is no risk of making mistakes.



## E-Light

As well as adding visual appeal and helping to highlight the handle, the extremely useful, LED-based E-Light “luminous progress bar” in the handle compartment changes colour as it moves through the different stages of the sterilization cycle, providing you with valuable information at a glance.

### Green light

End cycle, load sterile

### Yellow light

End cycle, load wet for prompt use

### Red light

Load not sterile



## E-Timer

Make the most of your time! Thanks to the innovative E-Timer, you can set tests and sterilization cycles to start at whatever time you like, allowing you to save time and start the working day at full speed.

# Traceability

## A new comprehensive traceability system

E10 features a new comprehensive and expandable traceability system. Full details of all sterilization cycles can be saved on an SD Card and transferred to a computer with the standard Ethernet connection and WiFi (optional). If other devices from the Euronada Pro System (such as Eurosafe 60, Euromatic® and Euroseal® Valida) are connected to the computer, the whole sterilization process can be monitored, validated and traced automatically. The E-Data system can connect one or more autoclaves to your management software for even more effective tracing of all cycles. In addition, with three different types of built-in printers available, E10 caters to a range of needs and allows you to save time completely safely.



**Print Set 1**  
Built-in thermal  
paper printer



**Print Set 2**  
Built-in adhesive  
label printer



**Print Set 3**  
External large-quantity  
labels printer



## Comprehensive traceability

Take your clinic into the future. You can connect a number of autoclaves and the other Pro System devices (Eurosafe 60, Euromatic® and Euroseal® Valida) to your management software, trace all data and attach the information to patient records. The E-Data software is available for both Windows and iOS and it is compatible with all of the top management systems on the market, such as Dios, Segosoft, Julie, Visident and Kodak.



## Validation and load release

This function allows users to keep a digital record of the compliance of the sterilization process in both the loading phase and the unloading phase. The operator ensures that the pouches are dry and checks their integrity and the state of the instruments, while also making sure that the sterilization parameters are satisfactory.



## Optional printers

E10's expandable traceability system caters to a range of needs, with a selection of three different optional printers. E10 can satisfy the traceability requirements of any practice and guarantee compliance with the legally established safety standards.



# Ergonomics

Total harmony between operator, device and environment





## Adaptable

Adapt your sterilization system to suit your working habits: choose freely between the 18 Litre and 24 litre versions of E10 in accordance with your practice's needs.



## Inspection<sup>®</sup> System

The tank compartment access system is extremely quick and simple. The upper cover is made of an innovative engineering plastic. It is held in place by a magnetic system which makes it easy to open at any time and enables even less proficient people to clean it easily and frequently. This guarantees safe sterilization that remains consistently effective in the long term.



## Modular structure

The side panels are made of cutting-edge materials and they are extremely easy to remove. In addition, the components inside the machine are easily accessible and positioned in a logical manner. This helps to make maintenance easier, faster and more effective.



Quick coupling  
on the front of the machine



Tank compartment  
access system



# Safety

Guaranteed quality  
throughout its working life





## Conductivity meter

The built-in conductivity meter monitors water quality and, if it is not satisfactory, E10 informs the operator with special messages on the E-Touch display.



## Dirt Control System

It is located in the hydraulic circuit and allows an exact separation of dirty and clean water. It makes the dirt easily flow in the used-water tank, so that the autoclave can work without problems.



## Air-water separator

The air-water separator device, designed and built into the tank unit, is a real “life saver” for the vacuum pump. The pumps used on machines of this level are essential to achieve proper sterilisation, but are very delicate as they are in constant contact with flows containing high temperature steam, air, dirt and chemical waste from lubricating oils found on instruments being sterilised (wands, turbines). These streams are channelled into the separator device which separates the air from the other components before they enter the vacuum pump. This phase allows the pump to operate in ideal working conditions, preserving the efficiency of the device.



## Support software

Euronda has developed a number of software applications to support technicians during the installation, diagnosis and maintenance processes. This helps to guarantee peak performance from E10 at all times while cutting assistance times and costs.

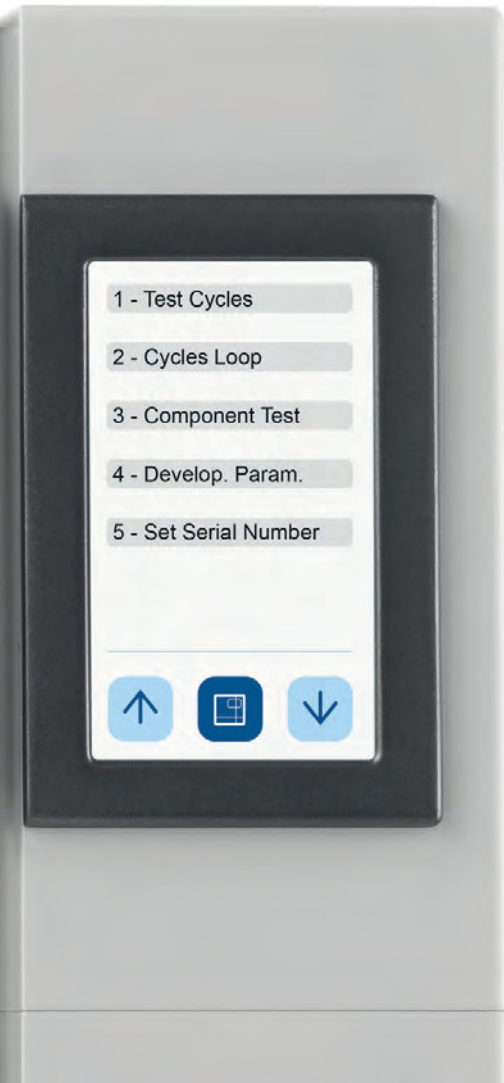

# Starter kit included

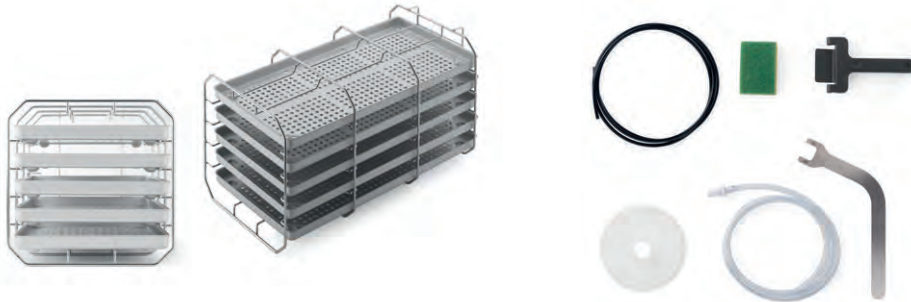

## Standard tray holder

Square profile steel tray holder with a capacity of five standard aluminium trays. If rotated by 90°, it can hold three sterilisation cassettes.

### Dimensions (wxhxd):

186 x 22 x 379 mm

### Five trays included

- Drainage pipes
- Sponge
- Tray removal handle
- Door adjustment handle
- Funnel
- Replacement bacteria filter

# Tests



## Helix Test

Test for Class B autoclaves to evaluate the capacity of penetration of the steam in hollow loads. Composed of a tube and 250 colour testers to confirm sterilization.

### Single pack

## Bowie & Dick Test

Test for Class B autoclaves to evaluate the penetration efficiency in porous loads.

### Single pack Carton of 10 pieces

## Prion Test

Test for Class B autoclaves, calibrated with the temperature, considered effective in 134°C Prion sterilization cycles (134°C x 18 minutes). Composed of 200 colour testers.

### Single pack

# Optional tray holders

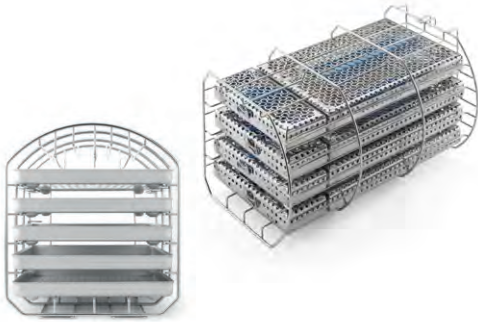

## Tray holder for sterilisation cassettes

Rounded steel tray holder designed to hold five standard aluminium trays. If rotated by 90°, it can hold four sterilization cassettes. Capacity: four 1 DIN cassettes + four 1/4 DIN cassettes.

**Trays not included**

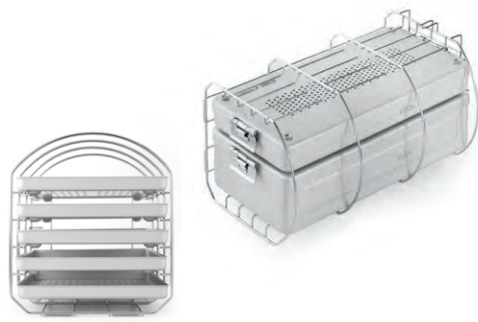

## Tray holder for sterilisation container

Rounded steel tray holder designed to hold five standard aluminium trays. If rotated by 90°, it can hold one or more sterilisation containers. Max. capacity: 190 x 152 x 380 mm (wxhxd).

**Trays not included**

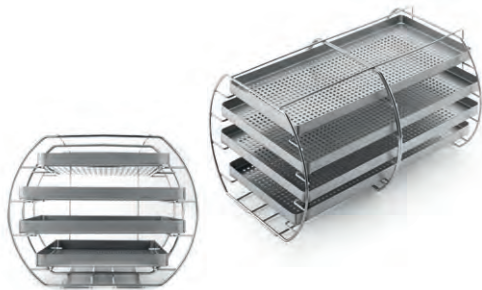

## XL tray holder kit

XL rounded steel tray holder, with a capacity of four special aluminium trays.

### **Trays dimensions (wxhxd):**

175 x 17 x 380 mm (upper and lower tray)

220 x 17 x 380 mm (central tray)

**Trays included in the kit**

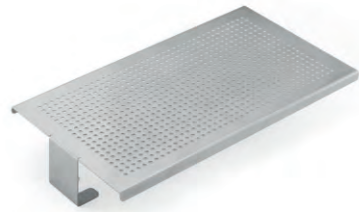

## Universal support surface

A steel support surface that is suitable for loads with greater dimensions. It can be installed directly in the boiler, after removing the tray holder provided.

### **Dimensions (wxhxd):**

194 x 53.5 x 350 mm - 24 L

194 x 53.5 x 250 mm - 18 L

# Traceability and connectivity



## Print Set 1

Built-in thermal paper printer for those who wish to print and store the results of the sterilization cycle on a paper copy. It can be installed on-board in a few simple steps on the front of the machine.



## Print Set 2

Built-in adhesive labels printer: safely tag your load. Install this simple printer device on board in a few easy steps. Save space and conveniently print your labels and bar codes.



## Print Set 3

External large-quantity labels printer for continuous production. Safely tag your load by connecting the printing device in a few easy steps. Can be used for both labels and bar codes.



## E-WiFi

Optional WiFi kit for connecting E10 and E9 autoclaves or Euroseal® Valida thermosealer to a computer, tablet or smartphone. With E-WiFi, all data are always available and updated in the computerized sterilization log. E-Link software, included in the kit, can be easily installed into a Windows or iOS operating system and allows to control up to five Euronda devices equipped with E-WiFi kit.



## E-Data & E-Memory software

E-Data software allows to link autoclaves and other Pro System Devices to your network system in order to have all the sterilization data available for your practice management software. E-Data is available for both Windows and iOS operating systems on the market, such as Dios, Segosoft, Julie, Visiodent and Kodak. E-Memory software manages the sterilization data on your computer. Thanks to this file management system you will have a complete and organized database of your sterilization process. Included in E10.

# Water treatment systems



## Aquaosmo

Aquaosmo is a system that uses reverse osmosis to produce deionized water. A complex filtering system, containing no fewer than four filters and 1 membrane, produces a large amount of water that is suitable for supplying autoclaves and all of the equipment in clinics, in accordance with the EN 13060 standard ( $<15 \mu\text{S}/\text{cm}$ ). A gun for spraying water manually can be also connected. Aquaosmo is designed to be installed together with an Aquabox and connected directly to an autoclave. It can supply up to four autoclaves at the same time if it is fitted with the special external accumulator tank kit, which has a capacity of 12 litres. Aquaosmo does not need to be connected to an electrical power supply and it can be installed directly on a work surface or inside a unit.

### It can supply:

4 autoclaves

### Water production:

1 litre of water every 20 min.

### Supply pressure:

Min. 2 / Max. 3 bars

### Conductivity of incoming water:

Max.  $650 \mu\text{S}$

### Dimensions (wxhxd):

360 x 280 x 180 mm

### Weight (empty):

5.3 Kg



**External accumulation tank**  
Included in the kit



**Aquabox**  
Included in the kit



**Nozzle**  
Not included in the kit



## Aquafilter 1 to 1

Device that produces deionized water for the autoclave, in compliance with the EN 13060 standard ( $<15 \mu\text{s}/\text{cm}$ ). It can be connected to one Euronda autoclave. Aquafilter deionises an average of 1 litre of water per minute. An indicator light shows the water conductivity level, allowing you to see at a glance when it's time to replace the resins. It can be equipped with an automatic shut-off device. It can be positioned on the worktop, inside a cabinet or it can be wall-mounted. The pack contains: two ion-exchange resin cartridges, a resin fixing tool, a water mains connection pipe, and a pipe and cable for connection to an Euronda autoclave.

**It can supply:**

1 autoclave

**Water production:**

1 L of water per min.

**Dimensions (wxhxd):**

390 x 455 x 145 mm

**Weight (empty):**

8.4 Kg





## Aquadist

Water distiller that boils water and condenses the steam to obtain distilled water. It distils 0.7 litres of water per hour. 4 litres capacity. It passes all safety tests, complying with all electromagnetic compatibility standard (2014/30/EU) and low voltage standard (2014/35/EU) requirements.

### **Water production:**

0,7 litre of water per hour

### **Dimensions (Øxh):**

230 x 360 mm

### **Weight (empty):**

3.5 Kg



## Aquabox

Aquabox is a device that allows Euronda autoclaves to be connected to an external supply of water that has already been treated. It is ideal for clinics that already have water treatment systems based on osmosis or other methods. It can be installed easily on all Euronda Class B autoclave models. Quality controls on incoming water are guaranteed for devices with conductivity meters.

### **Dimensions (wxhxd):**

100 x 100 x 50 mm

### **Weight:**

0.5 Kg



# Sterilisation cycles

	<b>B 134</b>		<b>B 121</b>		
	Solid, porous and hollow, wrapped and unwrapped		Solid, porous and hollow, wrapped and unwrapped. Particularly indicated for plastics, turbines and handpieces		
	<b>18 L</b>	<b>24 L</b>	<b>18 L</b>	<b>24 L</b>	
<b>Temperature</b>	134° c	134° c	121° c	121° c	
<b>Pressure</b>	2.05 bar	2.05 bar	1.05 bar	1.05 bar	
<b>Sterilization time</b>	4'	4'	20'	20'	
<b>Drying time</b>	15'	15'	15'	15'	
<b>Total time with standard loads*</b>	21'	24'	39'	40'	
<b>Maximum load solid/porous</b>	4.5 Kg / 1.5 Kg	6 Kg / 2 Kg	4.5 Kg / 1.5 Kg	6 Kg / 2 Kg	

# Personal functions

(Light\*\* and Light&Stock cycles\*\* can be activated on demand with a password)

	<b>S 134</b>		<b>S 121</b>		
	Sterilization of non-bagged or bagged solid products		Sterilization of non-bagged and plastic or bagged solid products		
	<b>18 L</b>	<b>24 L</b>	<b>18 L</b>	<b>24 L</b>	
<b>Temperature</b>	134°C	134°C	121°C	121°C	
<b>Pressure</b>	2.05 bar	2.05 bar	1.05 bar	1.05 bar	
<b>Sterilization time</b>	4'	4'	20'	20'	
<b>Drying time</b>	15'	15'	15'	15'	
<b>Total time with standard loads*</b>	17'	17'	29'	29'	
<b>Maximum load solid</b>	4.5 Kg	6 Kg	4.5 Kg	6 Kg	

\* Times are intended without drying. The times have a tolerance of +-5%.

\*\* All of the cycles are available unless it is not possible due to specific national legislation.

<b>B 134 prion</b>		<b>B 134 - rapid</b>		<b>B 134 prion - rapid</b>	
Prion cycle for wrapped and unwrapped solid, porous and hollow		Rapid cycle for wrapped and unwrapped solid, porous and hollow For 1 tray instruments		Rapid prion cycle for wrapped and unwrapped solid, porous and hollow For 1 tray instruments	
<b>18 L</b>	<b>24 L</b>	<b>18 L</b>	<b>24 L</b>	<b>18 L</b>	<b>24 L</b>
134° c	134° c	134° c	134° c	134° c	134° c
2.05 bar	2.05 bar	2.05 bar	2.05 bar	2.05 bar	2.05 bar
18'	18'	3'5"	3'5"	18'	18'
15'	15'	4'	4'	4'	4'
35'	37'	20'	23'	35'	37'
4.5 Kg / 1.5 Kg	6 Kg / 2 Kg	0.6 Kg / 0.2 Kg	0.6 Kg / 0.2 Kg	0.6 Kg / 0.2 Kg	0.6 Kg / 0.2 Kg

<b>N 134</b>		<b>N 121</b>	
Unwrapped solid instruments		Sterilization of non-bagged and plastic solid products	
<b>18 L</b>	<b>24 L</b>	<b>18 L</b>	<b>24 L</b>
134°C	134°C	121°C	121°C
2.05 bar	2.05 bar	1.05 bar	1.05 bar
4'	4'	20'	20'
4'	4'	4'	4'
18'	18'	33'	33'
4.5 Kg	6 Kg	4.5 Kg	6 Kg

# Technical data

	<b>E10 - 18 L</b>	<b>E10 - 24 L</b>
<b>Overall dimensions</b>	460 x 455 x 610 mm (wxhxd)	
<b>Weight</b> (machine empty with basket)	47,5 Kg	50,5 Kg
<b>Power supply</b>	230 V 50/60 Hz	
<b>Absorbed current</b>	2300 W 10 A	
<b>Operating temperature</b>	+5 - +40°C	
<b>Operating altitude</b>	≤ 2000 m a.m.s.l *	
<b>Minimum depth of the support surface</b>	500 mm	
<b>Minimum width of the support surface</b>	460 mm	
<b>Minimum space above the tank</b>	0 mm leaving the loading cap free	
<b>Noise level</b>	50 dB	
<b>Weight per support area</b> (tank full and chamber with max. load)	47,5 + 8,5 + 4,5 = 60,5 Kg Load on each foot: 15,125 Kg	50,5 + 8,5 + 6 Kg = 65 Kg Load on each foot: 16,25 Kg
<b>Operating range</b>	Indoor use - Relative humidity 85% Maximum line-voltage deviation ±10% Installation category II - Pollution level 2	
<b>Average water consumption per cycle</b>	300 ml	
<b>Tank capacity</b> (clean water / used water)	5 / 3.5 litres	

\* For altitudes higher than 2000m, please contact Euroonda SPA

## Safety Device

- Overpressure protection
- Accidental door opening protections
- Process appraisal system
- Real-time self diagnostic system

## Compliance with harmonised standards

EN 13060  
EN 14971  
EN 61010-1  
EN 61010-2-040  
EN 61326  
EN 13445

## Documentation

- User Manual
- Declaration of conformity chamber
- Declaration of conformity autoclave
- Warranty Certificate
- Installation chart
- Servicing handbook

## Certification information

- E10 Autoclave compliant with Directive 93/42/EC and addenda.
- Class II b device
- Chamber compliant with PED Directive 2014/68/EC
- Company certification: ISO 9001, ISO 13485
- CE Type Ref: E10- 18 L, E10- 24 L

# Technical Specifications

## Overall required space (mm)

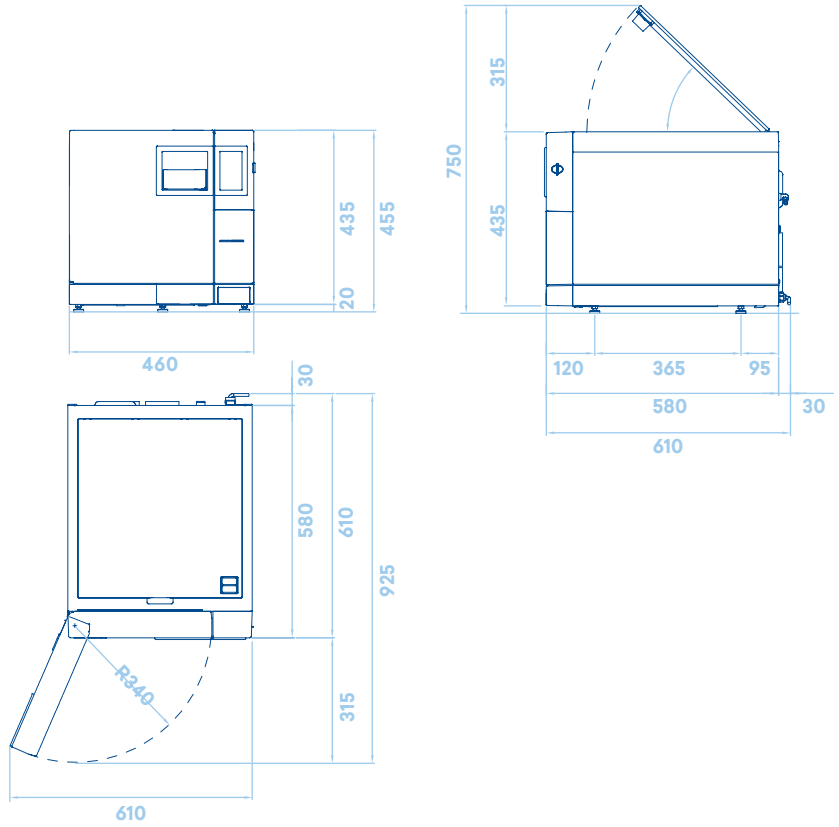

## Sterilization chamber sizes (mm) E10 - 18 L

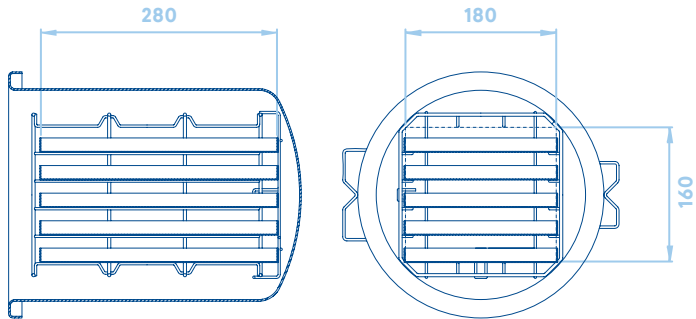

## Sterilization chamber sizes (mm) E10 - 24 L

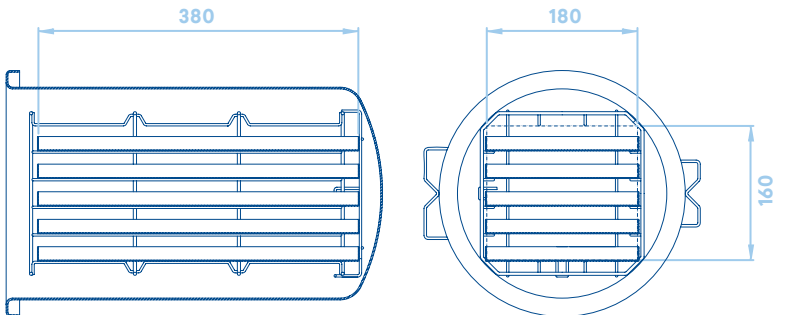

## **Euronda Spa® 2020**

This catalogue  
cannot be copied,  
scanned or reproduced  
by any means.  
All rights reserved.

Picture, description,  
quoting, dimension  
and technical data  
have to be considered  
as purely indicative.

While maintaining the  
basic characteristics  
of the product, the  
manufacturer reserves  
the right to make  
modifications at  
any time with the sole  
aim of improvement.



*Superior products, quality and service.*

WWW.LSRHEALTHCARE.COM.AU

Distributed by LSR Healthcare Pty Ltd

[www.lsrhealthcare.com.au](http://www.lsrhealthcare.com.au)

[enquiries@lsrhealthcare.com.au](mailto:enquiries@lsrhealthcare.com.au)

1300 859 767

**Euronda**<sup>®</sup>