

FEATURES

- Fan cooling, 0-10°C
- Power coated steel interior and exterior
- Self-evaporating water tray
- 2 x vertical internal LED lights and canopy LED light
- Digital control with led display, auto-defrost
- Double layer glass door, tempered glass
- Self-closing door with lock and key
- 4 strong castors, front 2 with brakes



P380WA



P1000WB-A

INFORMATION	P380WA	P1000WB-A
Capacity	380L	1000L
Power	300W	550W
Voltage	220V~240V/50Hz	220V~240V/50Hz
Working Temp	0°C~+10°C	0°C~+10°C
Ambient Temp	38°C	38°C
Dimensions(mm)	W606 x D620 x H1940,75kg	W1130 x D720 x H2023,142kg
Packaging Dimensions(mm)	W645 x D665 x H2005,80kg	W1180 x D770 x H2100,160kg
RRP	\$1,295.00	\$2,295.00

CE MEPS



2 YEARS WARRANTY ON ALL PARTS & LABOUR
* EXTRA 2 YEARS WARRANTY ON PARTS WHEN YOU REGISTER WITH US ONLINE

BOTTOM MOUNTED REFRIGERATORS

P380WA

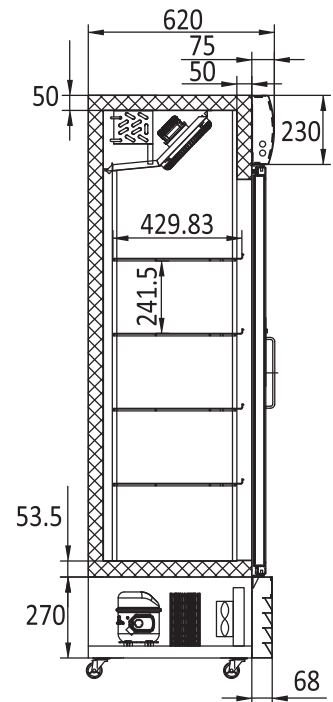
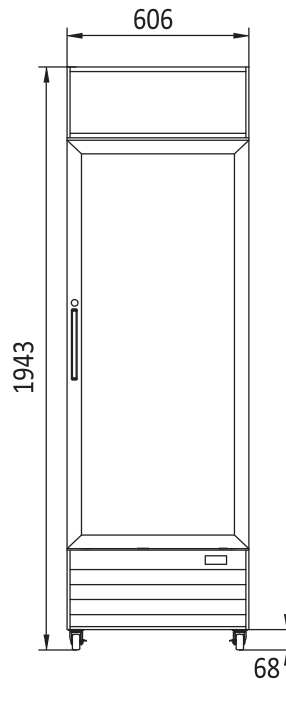
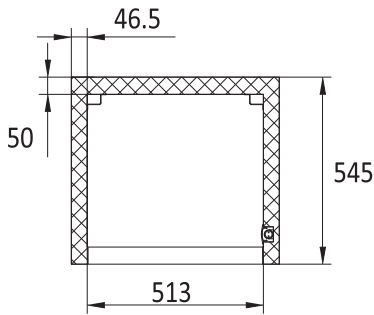

P1000WB-A

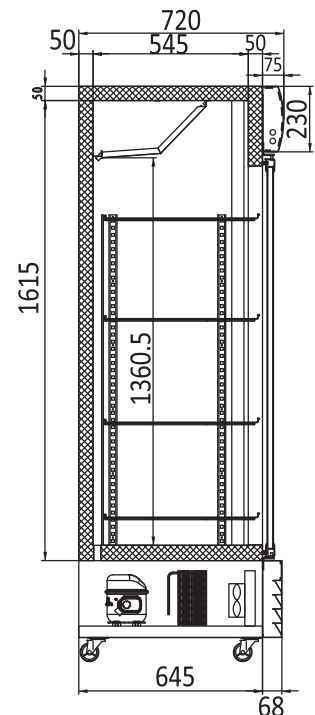
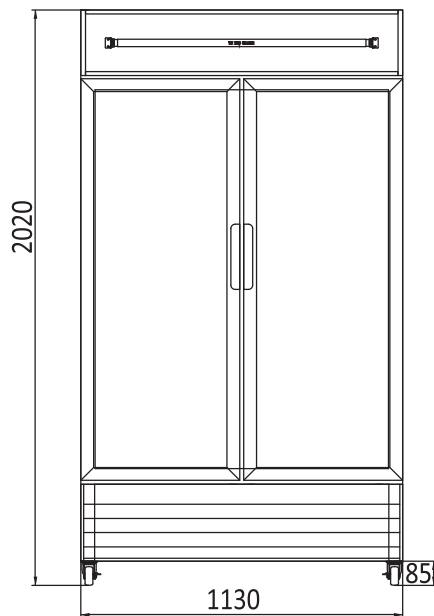
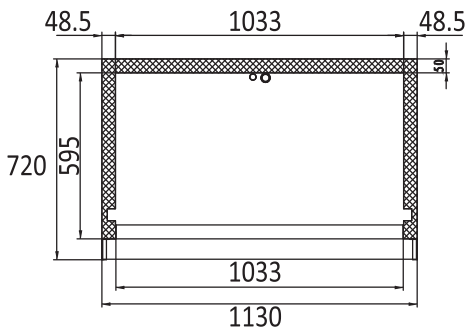

CE MEPS



+



2 YEARS WARRANTY ON ALL PARTS & LABOUR
 * EXTRA 2 YEARS WARRANTY ON PARTS WHEN YOU REGISTER WITH US ONLINE