

CC1W Wireless Load Cell



product description

The model CC1W is revolutionary new wireless pump off control load cell. The CC1W utilizes the same design attributes as our established CC1 but eliminates the need for the cable connection.

The load cell is powered by a readily available D-cell battery that can power the unit for 12 – 18 months.

The technology behind the CC1W sets it apart from all wireless products currently available in the market. The primary advantage is an extremely low power consumption, which is able to deliver a continuous flow of data, high signal strength and a long battery life. In addition, the CC1W offers built-in position sensing capabilities, which is synchronized with the load measurement, eliminating the need for hall effect sensors or inclinometers.

The CC1W is made up of two parts, the load cell and a base unit.

The load cell has a fixed signal transmitter, with an easy access enclosure for battery replacement. The base unit is mounted and wired to the pump control system, allowing the load cell to transmit encrypted data wirelessly.

The body of the CC1W is based on our proven CC1 load cell, which is manufactured from stainless steel and hermetically sealed.

applications

Pump off control (polished rod load cell)

key features

Capacity of 30 klb (13.6 t) & 50 klb (22.7 t)

UL Approved Class 1, Div 1

100 readings per second

Position sensing capability

12 - 18 month battery life

High signal strength with encryption

IP67 and rated for use in -70° to 175°F (-55° to 80°C)

Fatigue rated to a minimum 50,000,000 life cycle

accessories

Spherical washers

Load plates

Magnetic mount, post mount or DIN rail mount for base unit



specifications

Maximum capacity (E_{max})	lbf	30k & 50k
Rated load output	m/V/V	2.00 ± 0.5%
	mA (optional)	4-20
Rated position output	% FS (Stroke)	± 0.5% (TBC)
Nonlinearity	% FS	± 0.25
Hysteresis	% FS	± 0.25
NonRepeatability	% RO	±0.1
Static Error Band	% FS Max	± 0.50
Compensated Temperature Range	°F (°C)	-14° - 150° (-25° to 65°)
Safe Operating Temperature Range	°F (°C)	-70° - 175° (-55° to 80°)
Temperature Effect on Zero	%RO/°F Max	± 0.005
Temperature Effect on Output		± 0.002
Zero Balance	% RO Max	± 1
Safe, axial load	% Capacity Max	200
Deflection at Capacity	inch nom	0.005
Load cell weight	lb nom	4.5
Fatigue Rating (compression)	Cycles Min @ Capacity	50,000,000
Shock Rating	g	Up to 500g
Vibration Rating	MIL-STD-810G	514.6; 516.6
Sensor construction	17-4 PH Stainless Steel	
Protection according EN60529	IP67 or higher	

Electronics

Remote & base transceiver units matched	Mac ID	(32bit) Specific; no external connection - paired unit
Data rate	Readings/sec	100
Radio frequency	GHz	2.405 to 2.470
Radio Channels	Selectable (*)	14
Telemetry Range	Feet (Meters) (*)	100 - 1000 (30-300)
RF Power Output- Remote Unit	dBm (*)	Min = 13.0dBm, Max = 15.5dBm
RF Power Output- Base Unit	dBm (*)	Min = 16.0dBm, Max = 17dBm
Battery Life	Min @ 100 rps (**)	12 - 18 months
Battery Type	Remote Battery	(TL-5930/F) Lithium D Cell, 3.6VDC, 19Ah
Housing Material	Grivory GV-5H (Glass reinforced plastic)	

Base Unit

Power Supply	VDC, mA	12 - 24 ; Min. 250mA
External Ref. (Virtual Excitation) Voltage	VDC	4.8-10.1
Virtual Bridge Resistance	Ω	700
Housing Material	Die-cast Aluminium	

(*) 2-3dBm; Telemetry range will change according to site RF Channel Settings

(**) Battery Life changes as per RF output; latency; Temp; antenna distances etc.



product dimensions (mm)

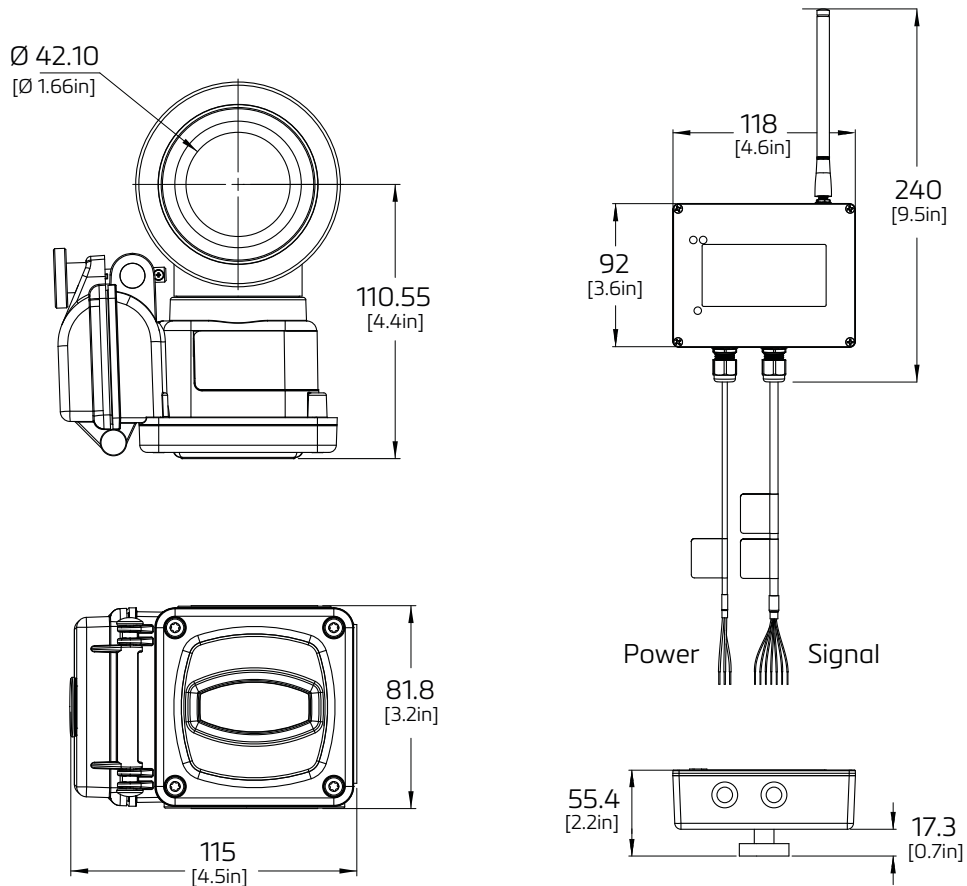

wiring (base unit)

Wiring connections for base unit as follows. Load cell powered by battery. See user manual for full details.

Caution! Base unit is not intended to meet safety certifications. Use appropriate safety procedures when installing.

Power cable

Black	Ground
Yellow	Shield
Red	12 to 24VDC

Signal cable

Red	Vref +
Green	Sig +
White	Sig -
Black	Vref -
Yellow	Shield
Gray	Sig 2 +
Violet	Sig 2 -

Specifications and dimensions are subject to change without notice.