



全自動

Fully Automatic

超硬鎢鋼圓鋸切斷機

Tungsten Carbide Circular Sawing Machine

THC
SERIES



多樣鋸切能力
Variety Sawing Capacity

CE ISO-9001:2008

THC
SERIES



TCT



全自動超硬鎢鋼圓鋸切斷機

Fully Automatic **Tungsten Carbide** Circular Sawing Machine

高速超硬鎢鋼圓鋸切斷機，對於鋼材做精密切斷，速度快、效率高、表面光滑、精度高，對各種實心棒、角鋼做最完美切斷，鋼管採用HSS鋼圓鋸切斷。而THC-NA系列專作為鋁金屬實心棒、角鋁材、鋁管切斷。

The THC series High Speed Tungsten Carbide Sawing Machine is designed and engineered to create optimum cutting performance. It features high speed, efficiency, and accuracy and also smooth surface of cut. The THC series is especially ideal for cutting solid bars and angular steel.

Also suitable for cutting Stainless Steel & Steel pipe by using a HSS sawblade.

The THC-NA series is especially ideal for cutting aluminum solid bars, angular aluminum, and aluminum pipe.

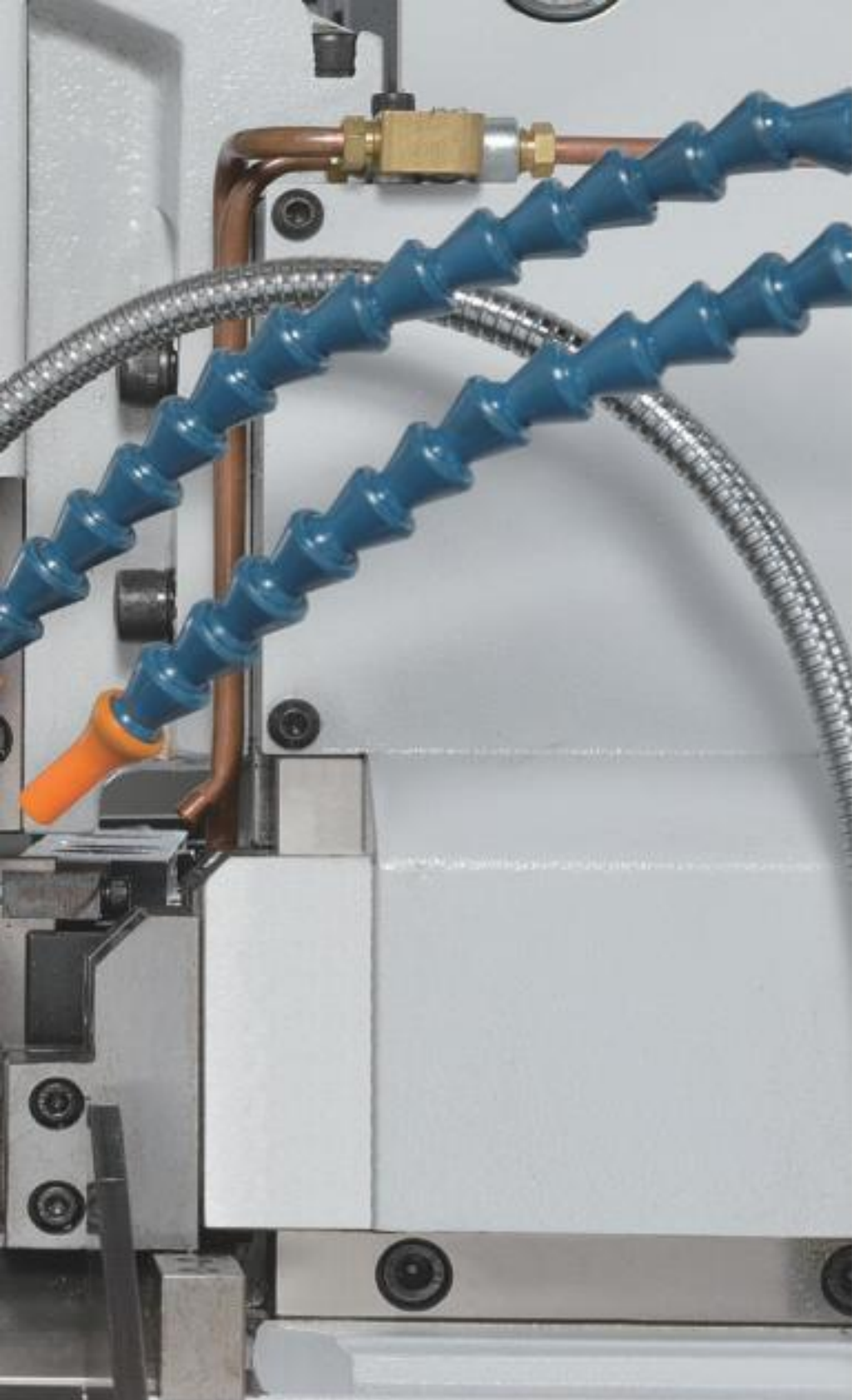

























Optimum Sawing Capacity 最佳的切鋸能力

- 多樣切鋸能力
- 切鋸面平滑
- 配備最齊全
- 精度最高
- 速度最快
- 效率提升





















- Variety Sawing Capacity
- Smooth Surface
- Fully Equipped
- High Accuracy
- High Speed
- High Efficiency



機型 Model

機型 Model	送料 Transmission	切斷 Cutting Motion	
	伺服馬達驅動 滾珠螺桿送料 Servo-motor Drive Ball Screw Feed	頭部油壓進給切斷 Hydraulic Driven Sawhead Feed for Cutting Motion	頭部伺服馬達驅動 滾珠螺桿進給切斷 Sawhead Driven by Servo-motor Ball Screw Transmission for Cutting
 THC-A70NC			
 THC-B70NC			
 THC-B76NC			
 THC-B90NC			
 THC-BNA102NC			 鋁銅切斷 Aluminum Copper Cutting
 THC-A101NC			
 THC-B101NC			
 THC-A130NC			

機型 Model

機型 Model	送料 Transmission	切斷 Cutting Motion	
	伺服馬達驅動 滾珠螺桿送料 Servo-motor Drive Ball Screw Feed	頭部油壓進給切斷 Hydraulic Driven Sawhead Feed for Cutting Motion	頭部伺服馬達驅動 滾珠螺桿進給切斷 Sawhead Driven by Servo-motor Ball Screw Transmission for Cutting
THC-B130NC 			
THC-A150NC 			
THC-B150NC 			
THC-A165NC 			
THC-B165NC 			
THC-NA168NC 		 鋁銅切斷 Aluminum Copper Cutting	
THC-BNA168NC 			 鋁銅切斷 Aluminum Copper Cutting

倒角 Chamfering

◀ 輸送 Connecting

◀ 切斷 Cutting

全自動化整廠設備
Complete Workflow Planning



標準配備提高您的產能 Standard Equipped High Capacity



標準配備 Std.	刀具間隙 補償裝置 Sawblade Gap Compensation Device	刀具偏擺 防震錫鋼墊塊 Tungsten Pad for Sawblade Run-out	殘屑清除 鋼絲滾輪 Chip Removing Steel Brush Wheel	刮板式 排屑裝置 Scraper Type Chip Conveyor	噴霧式 冷卻裝置 Mist Cooling Device	切削液 冷卻裝置 Cutting Fluid Cooling Device	角材 滑動裝置 Angular Steel Slicing Device	工作燈 Work Light
機型 Model								
THC-A70NC								
THC-B70NC	✓	✓	✓	✓	✓	✓	✓	✓
THC-B76NC								
THC-B90NC								
THC-BNA102NC	—	✓	—	✓	✓	✓	✓	✓
THC-A101NC								
THC-B101NC								
THC-A130NC								
THC-B130NC	✓	✓	✓	✓	✓	✓	—	✓
THC-A150NC								
THC-B150NC								
THC-A165NC								
THC-B165NC								
THC-NA168NC	—	✓	✓	✓	✓	✓	—	✓
THC-BNA168NC	—	✓	—	✓	✓	✓	—	✓

P6A

手積排列料架
Manual Stack Line Up Loader
(THC-130NC)



自動油壓舉料
Automatic
Hydraulically
Operated
Material
Lifting

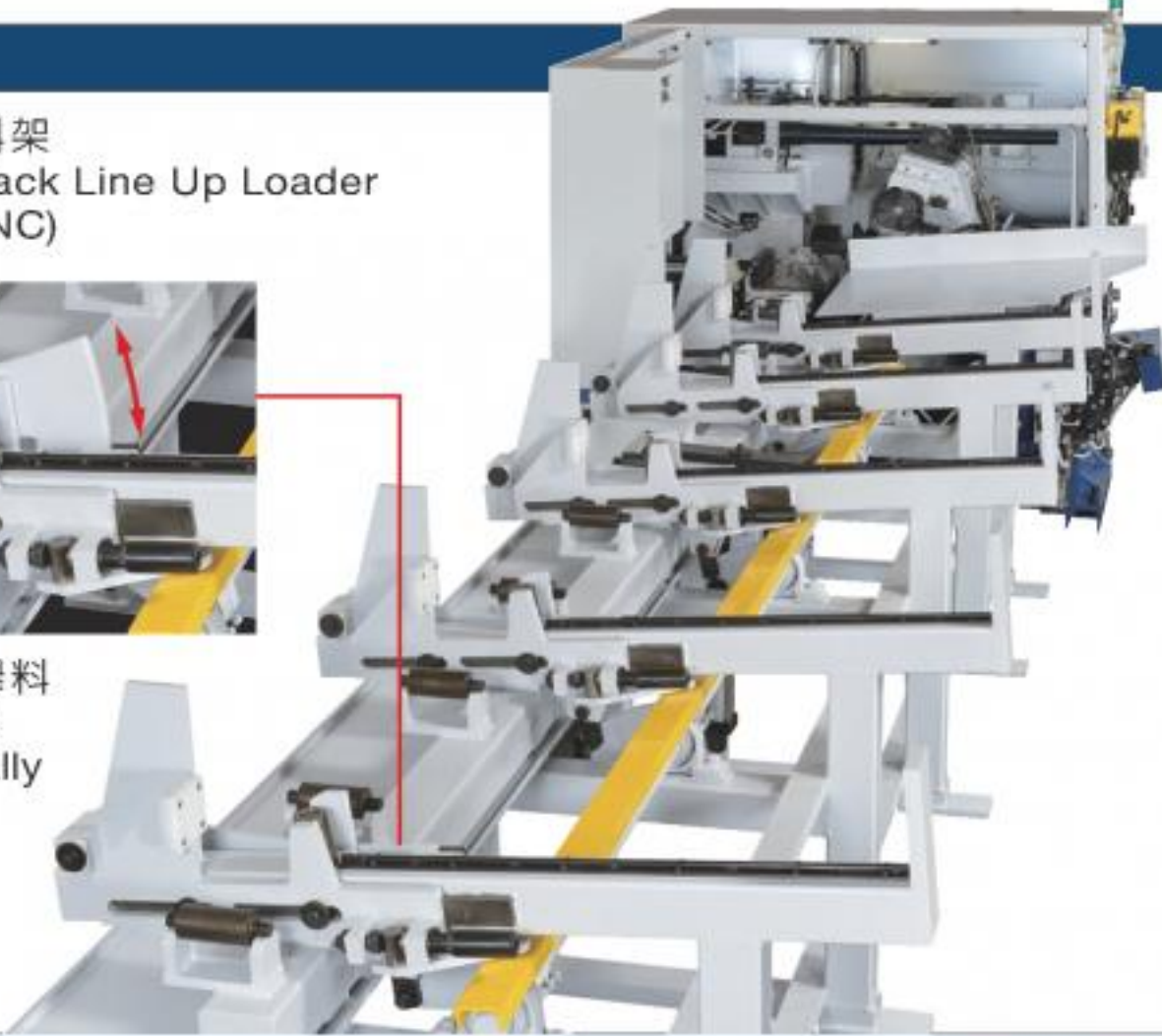

P6B

POD
觸控螢幕操作面盤
Touch Sensing Screen



- 主畫頁
Menu Display
- 自動執行畫頁
Auto Run Display
- 機台監視畫頁
Machine Monitor Display
- 手動操作畫頁
Manual Operation Display
- 設定畫頁
Setting Display
- 多國語言
Multi-lingual

P6C

線性滑軌 Linear Slides

滾珠螺桿 Ball screw

(THC-B90NC)

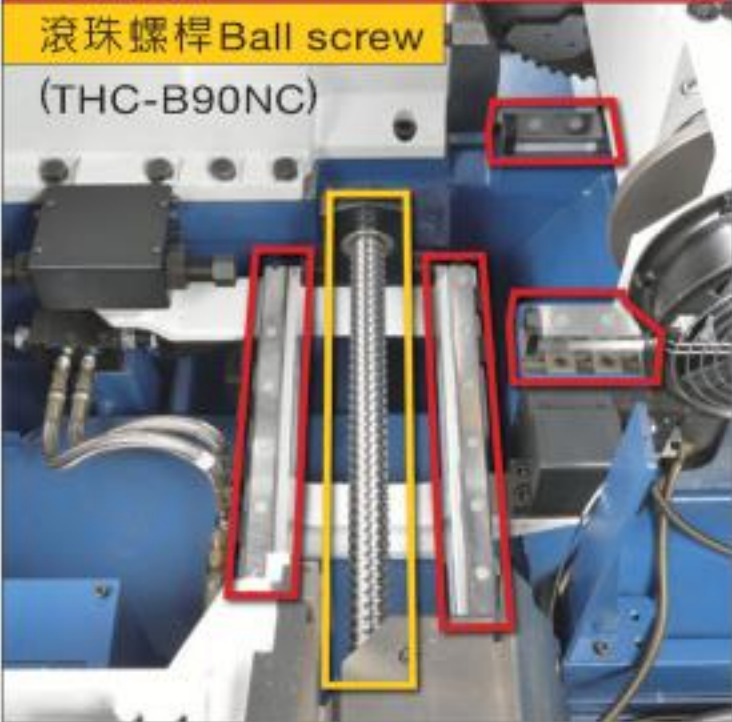

P6D

伺服馬達滾珠螺桿驅動送料
Feed System is Driven by
Servo-motor With Ball
(THC-B130NC)



P6E

噴霧潤滑裝置
Mist Lubrication
Device



P6F

頭料、尾料與工件自動分料
Head and Tail Pcs are Separated
with Workpieces Automatically

Automatic material outfeed +
The first and second workpieces
are outfed separately.

Head and end pieces are
outfed at left and right sides.



P6G

刮板式排屑裝置
Chain Type
Chip Conveyor



選購配備滿足您的需求 Optional Equipment Meet Your Needs

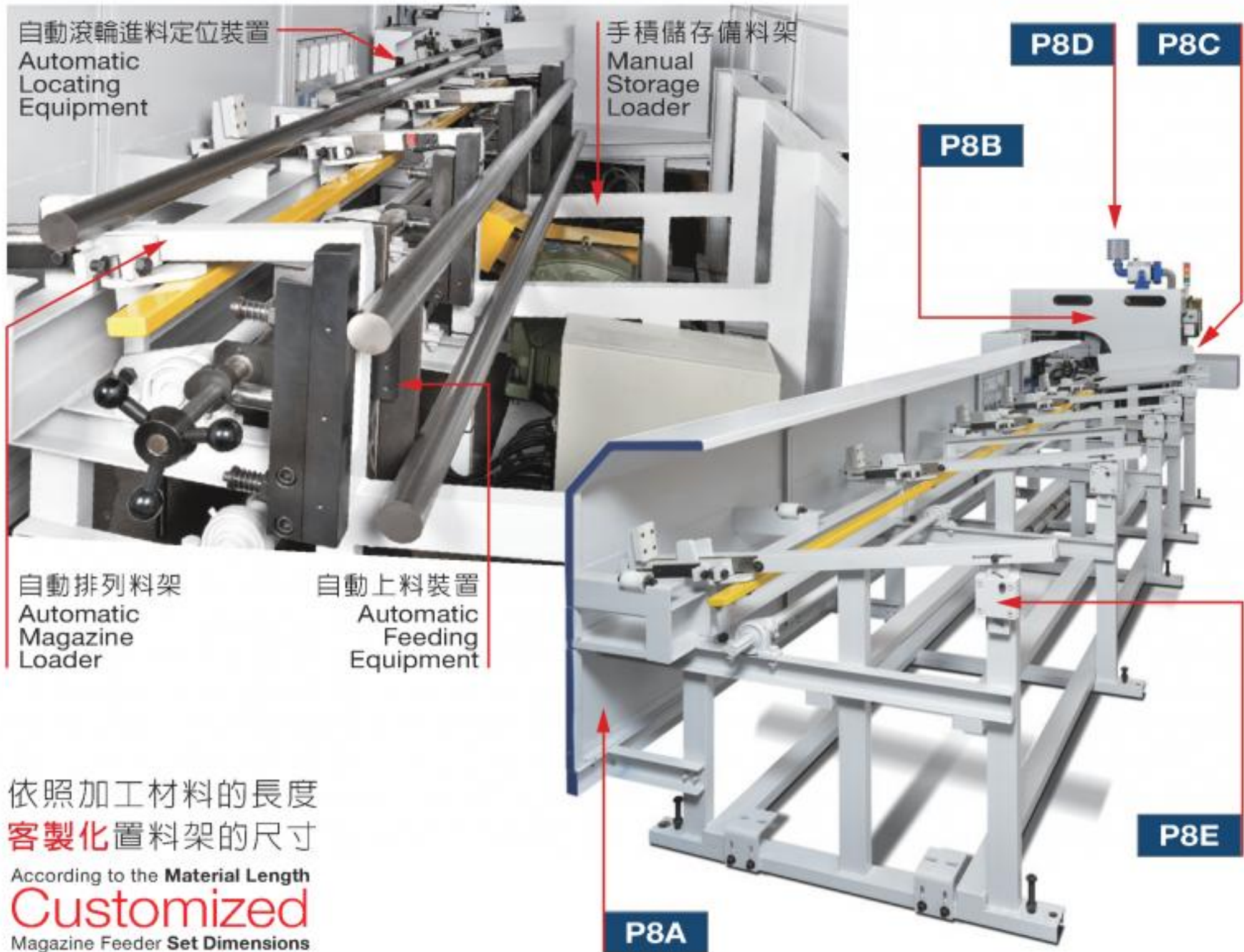

依照加工材料的長度
客製化置料架的尺寸

According to the **Material Length**
Customized
Magazine Feeder **Set Dimensions**

選購配備 Opt.	TCT 超硬鎢鋼 圓鋸片 Carbide Sawblade	HSS 高速鋼 圓鋸片 Sawblade	TIP 鋼鋁鎢鋼 圓鋸片 Aluminum Carbide Sawblade	鋁屑 集塵設備 Aluminum Dust Collector	油霧回收機 Oil Mist Collector	切削液 Cutting Fluid	角材 滑動裝置 Angular Steel Slicing Device	自動滾輪 出料裝置 Automatic Roller Out Feeding Device	手積儲存 備料架 Manual Storage Loader	自動 上料裝置 Automatic Feeding Equipment	自動 排列料架 Automatic Magazine Loader	自動滾輪 進料定位裝置 Automatic Locating Equipment
機型 Model												
THC-A70NC												
THC-B70NC	✓	✓	-	-	✓	✓	-	✓	✓	✓	✓	✓
THC-B76NC												
THC-B90NC												
THC-BNA102NC	-	-	✓	✓	✓	✓	-	✓	✓	✓	✓	✓
THC-A101NC												
THC-B101NC	✓	✓	-	-	✓	✓	✓	✓	✓	✓	✓	✓
THC-A130NC												
THC-B130NC												
THC-A150NC												
THC-B150NC	✓	-	-	-	✓	✓	✓	✓	✓	✓	✓	✓
THC-A165NC												
THC-B165NC												
THC-NA168NC	-	-	✓	✓	✓	✓	✓	✓	✓	✓	✓	✓
THC-BNA168NC												

P8A

送料安全保護蓋
Feeding Safety Guard



半罩式送料安全保護蓋
Feeding Safety Guard



全罩式送料安全保護蓋
Fully Feeding Safety Guard

P8B

HSS 高速鋼圓鋸片
Circular Saw Blade



TCT 超硬鎢鋼圓鋸片
Extra Hard Tungsten Carbide
Circular Saw Blade



P8C

自動滾輪出料裝置
Automatic Roller
Out Feeding Device
150~350mm



P8D

油霧回收機
Oil Mist Collector



P8E

角材助滑動裝置
Angular Steel Slide
Assistance Device



參考鋸刃外徑與材料外徑

Cutting Capacity for Various Workpiece Shape

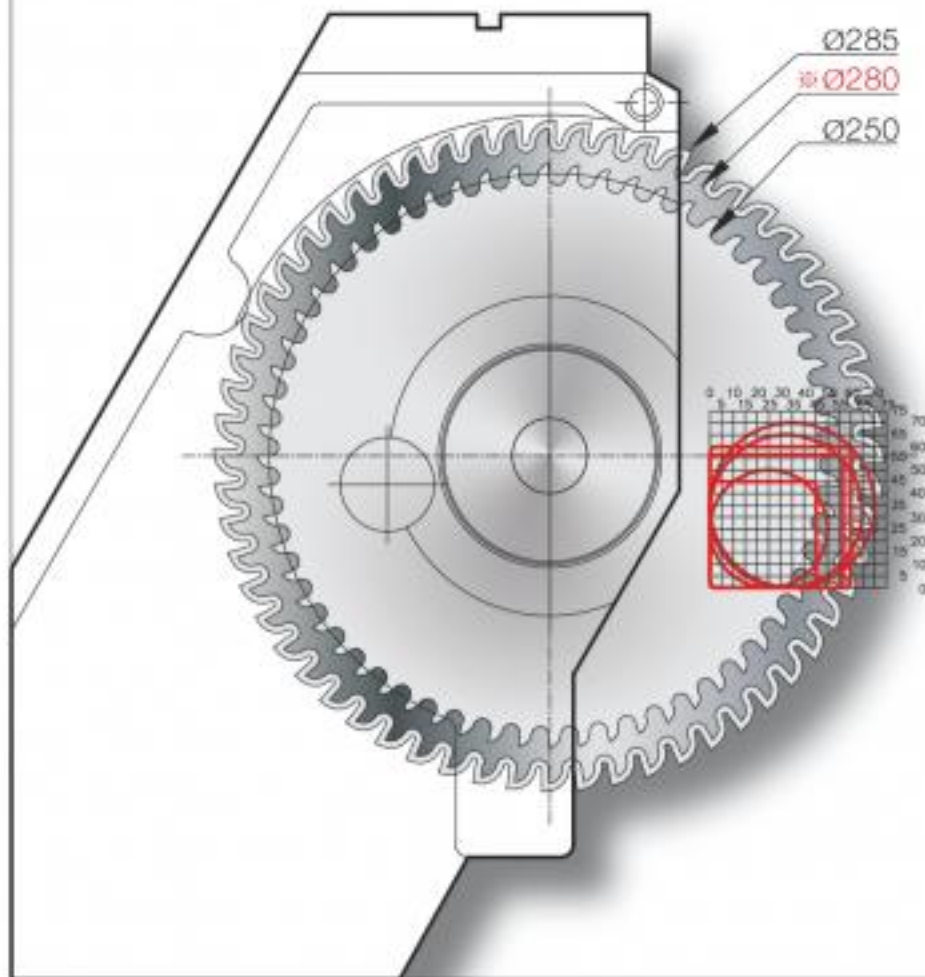

THC-A70NC / THC-B70NC

材質: 鋼 管材厚度: ≤2.5 ~ 3.5mm以上
Material: Steel Pipe Thickness: ≤2.5 - 3.5mm

鋸刃外徑 Sawblade Dia.	● ○	■ □	▬ □
Ø250	Ø50	45 x 45	40 x 45
*Ø280	Ø65	57 x 57	52 x 60
Ø285	Ø70	60 x 60	55 x 60

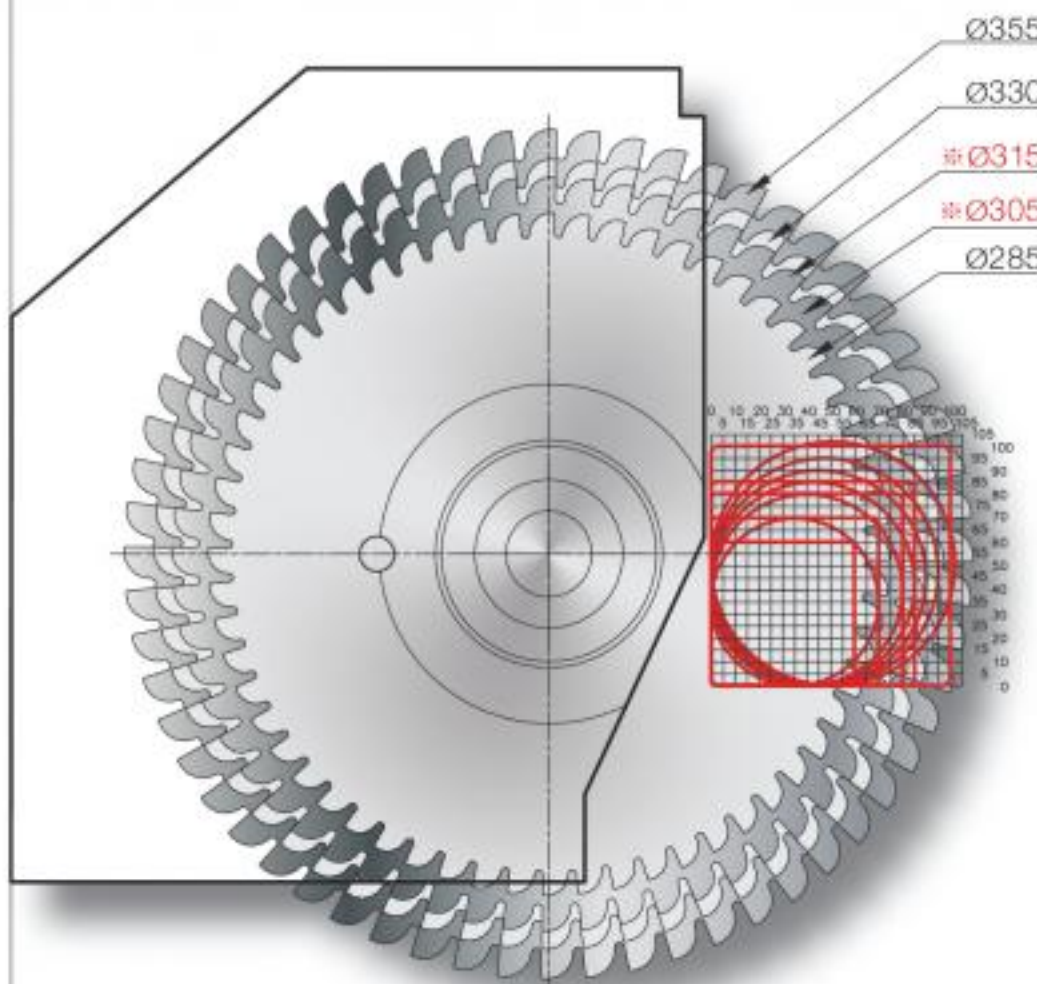

THC-B76NC

材質: 鋼 管材厚度: ≤2.5 ~ 3.5mm以上
Material: Steel Pipe Thickness: ≤2.5 - 3.5mm

鋸刃外徑 Sawblade Dia.	● ○	■ □	▬ □
Ø285	Ø72	60 x 60	55 x 60

THC-B90NC

材質: 鋼 管材厚度: ≤2.5 ~ 4.5mm以上
Material: Steel Pipe Thickness: ≤2.5 - 4.5mm

鋸刃外徑 Sawblade Dia.	● ○	■ □	▬ □
Ø285	Ø70	60 x 60	55 x 60
*Ø315	Ø85	80 x 80	75 x 80
Ø330	Ø90	85 x 85	80 x 85

THC-BNA102NC

材質: 鋁 管材厚度: ≤2.5 ~ 5.5mm以上
Material: Aluminum Pipe Thickness: ≤2.5 - 5.5mm

鋸刃外徑 Sawblade Dia.	● ○	■ □	▬ □
*Ø305	Ø80	70 x 70	65 x 70
Ø355	Ø102	100 x 100	95 x 100

※ 特別鋸刃外徑 (選購配備)
Sawblade Diameter (Optional)

○ 圓管
Round Pipe

□ 方管
Square Pipe

▭ 長方管
Rectangle Pipe

● 圓形材
Round Bar

■ 方形材
Square Bar

▬ 長方形材
Rectangle Bar

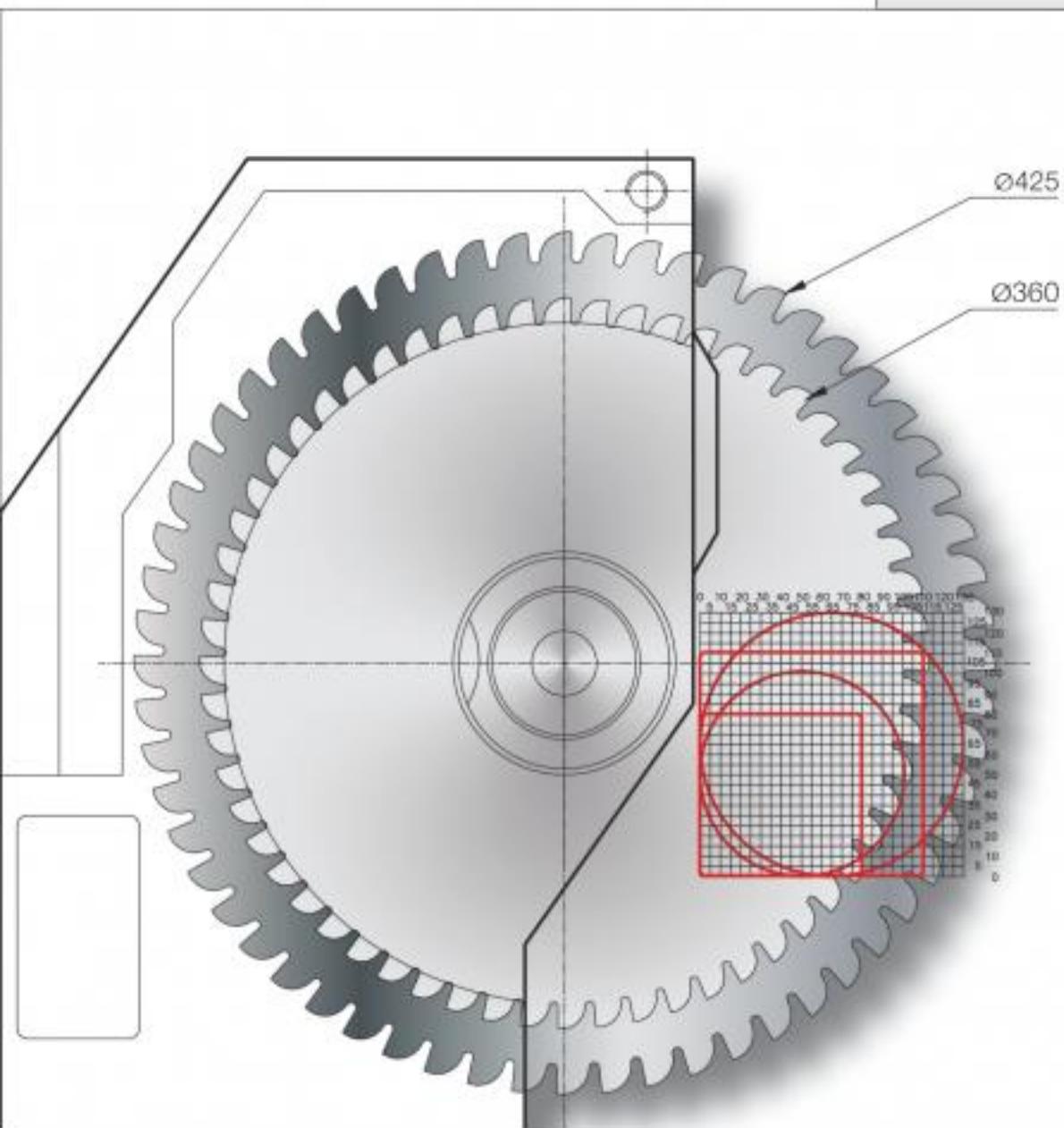

THC-A101NC / THC-B101NC

材質: 鋼 管材厚度: ≤2.5 ~ 5.5mm以上
Material: Steel Pipe Thickness: ≤2.5 ~ 5.5mm

鋸刃外徑 Sawblade Dia.	● ○	■ □	▭ ▭
Ø360	Ø102	80 x 80	75 x 80

THC-A130NC / THC-B130NC

材質: 鋼 管材厚度: ≤5.0 ~ 6.0mm以上
Material: Steel Pipe Thickness: ≤5.0 ~ 6.0mm

鋸刃外徑 Sawblade Dia.	● ○	■ □	▭ ▭
※ Ø360 Ø425	Ø102 Ø130	80 x 80 110 x 110	75 x 80 100 x 110

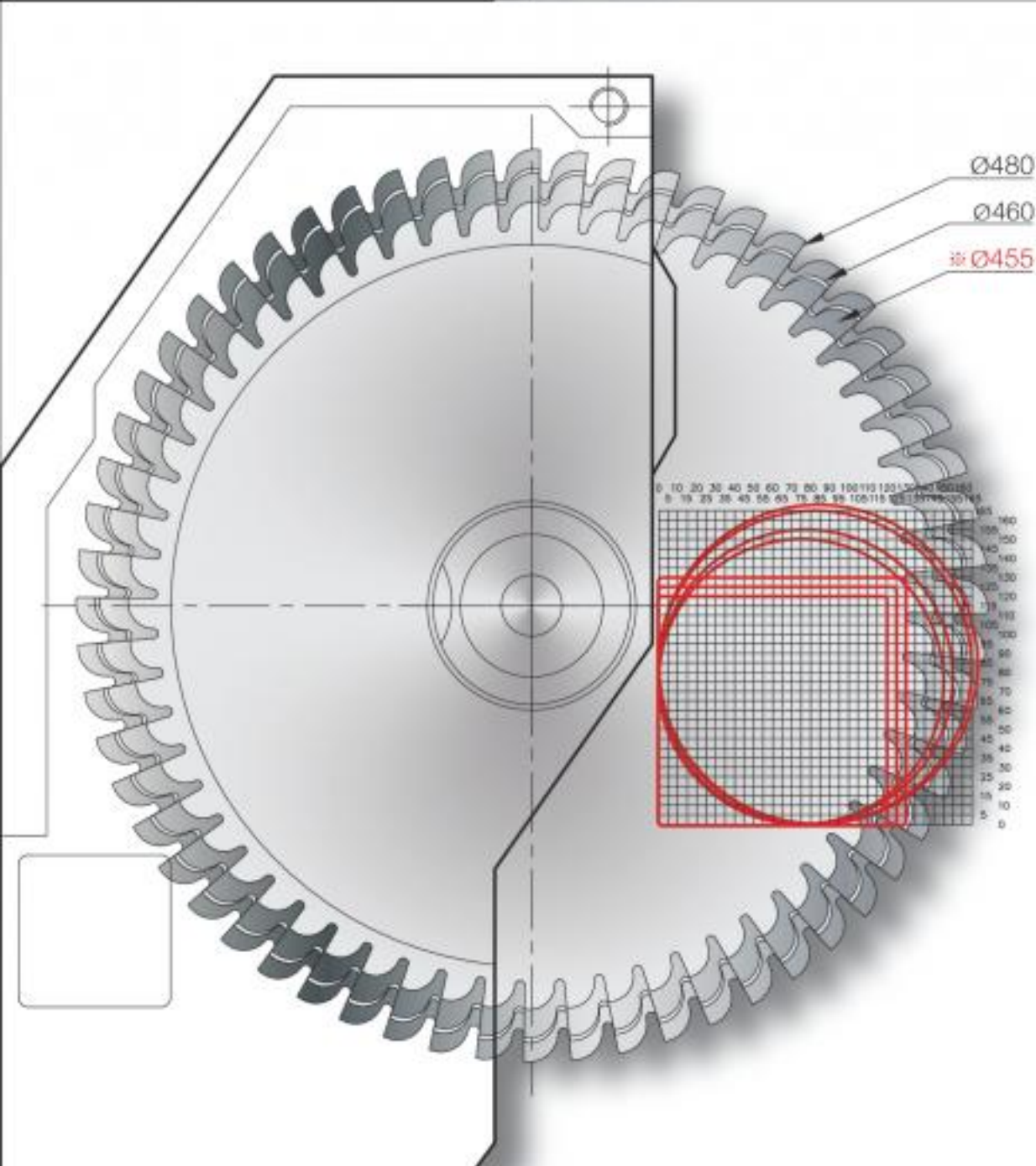

THC-A150NC / THC-B150NC

材質: 鋼 管材厚度: ≤6.0 ~ 8.0mm以上
Material: Steel Pipe Thickness: ≤6.0 ~ 8.0mm

鋸刃外徑 Sawblade Dia.	● ○	■ □	▭ ▭
Ø460	Ø155	125 x 125	115 x 125

THC-A165NC / THC-B165NC

材質: 鋼 管材厚度: ≤6.0 ~ 8.0mm以上
Material: Steel Pipe Thickness: ≤6.0 ~ 8.0mm

鋸刃外徑 Sawblade Dia.	● ○	■ □	▭ ▭
※ Ø460 Ø480	Ø155 Ø165	125 x 125 130 x 130	115 x 125 120 x 130

THC-NA168NC / THC-BNA168NC

材質: 鋁 管材厚度: ≤8.0 ~ 11.0mm以上
Material: Aluminum Pipe Thickness: ≤8.0 ~ 11.0mm

鋸刃外徑 Sawblade Dia.	● ○	■ □	▭ ▭
※ Ø455 Ø480	Ø150 Ø168	120 x 120 130 x 130	110 x 120 120 x 130

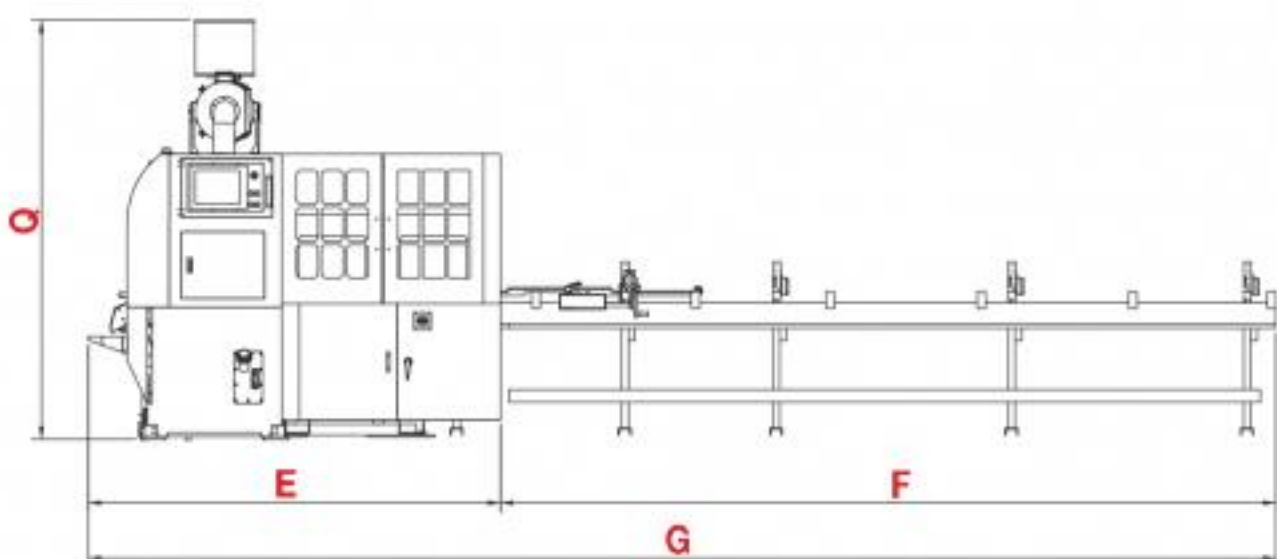
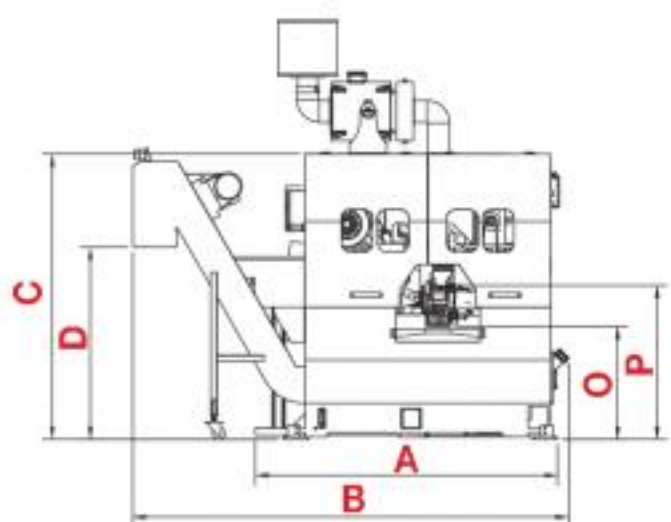
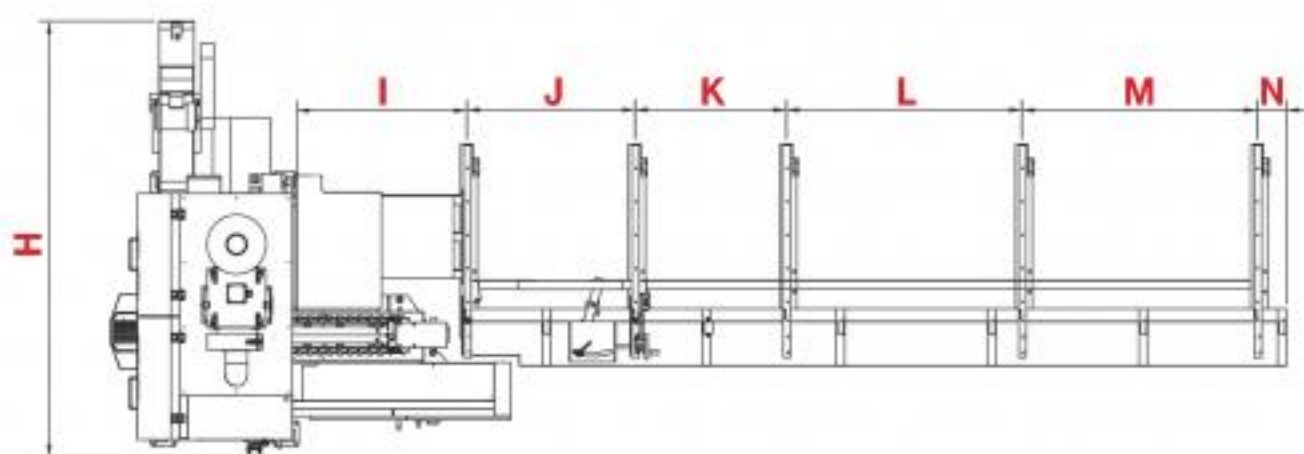

機型 Model	A	B	C	D	E	F	G	H	I	J	K	L	M	N	O	P	Q
THC-A70NC																	
THC-B70NC	1745	2515	1803	1150	2282	4592	6874	2515	946	1000	900	1400	1400	187	600	900	2600
THC-B76NC																	
THC-B90NC	1796	2515	1697	1150	2450	4611	7061	2515	946	1000	900	1400	1400	187	600	906	2492
THC-BNA102NC																	
THC-A101NC																	
THC-B101NC																	
THC-A130NC																	
THC-B130NC																	
THC-A150NC	1765	2900	1837	1150	2500	4200	6700	2900	990	750	1050	1200	1200	330	550	910	2632
THC-B150NC																	
THC-A165NC																	
THC-B165NC																	
THC-NA168NC																	
THC-BNA168NC																	

機型	Model		THC-A70NC THC-B70NC	THC-B76NC
鋸切能力	Cutting Capacity		TCT超硬鎢鋼圓鋸片 / HSS 高速鋼圓鋸片 TCT carbide sawblade / HSS sawblade	
棒材	Round Solid Bar	mm	● 10-70 (Ø8-10 Opt.選配)	● 15-72 (Ø10-Ø15 Opt.選配)
角材	Square Solid Bar	mm	■ 10-57	■ 10-60
長方形	Rectangle	mm	■ 10-57	■ 10-60
圓管	Round Pipe	mm	○ 10-70 (Ø8-10 Opt.選配)	○ 10-72
方管	Square Pipe	mm	□ 10-57	□ 10-60
先端切斷長度最大	Maximum Length of Head Cut	mm	10-60	10-60
尾端殘材長度	Waste Material Length at Tail End	mm	65-(65 + * 切斷長度Cutting length)	55-(55 + * 切斷長度Cutting length)
送料長度	Feeding Length	mm	5-600 連續循環動作Continuous cycles	
手積排列料架承載	Manually Stack Line-up Loader Capacity	kg	2500	3000
材料長度	Material Length	mm	2000-6000	2000-6000
置料長度	Material Loading Width	mm	950	950
機械規格	Machine Specifications			
使用TCT超硬鎢鋼圓鋸片 TCT Carbide Sawblade			Ø250-Ø285 × t2.0	Ø285 × t2.0 (Std.標準) Ø315 × t2.25 (Opt.選配)
銷孔+孔徑	Pin Holes + Bore	mm	4 × Ø11 × PCD63 × Ø32	4 × Ø11 × PCD63 × Ø32
使用TIP鋁鎢鋼圓鋸片 TIP Aluminum Carbide Sawblade		mm	—	—
銷孔+孔徑	Pin Holes + Bore	mm	—	—
使用HSS高速鋼圓鋸片 HSS Sawblade		mm	Ø250-Ø285 / t1.5-2.5	Ø285-Ø315 t1.5-t2.25
主軸馬達	Spindle Motor	kw	7.5 (10HP)	9 (12HP)
主軸轉速	Spindle Speeds	rpm	17-200	50-180
變頻器	Frequency Inverter	kw	11 (15HP)	11 (15HP)
油壓馬達	Hydraulic Pump Motor	kw	2.2 (3HP)	2.2 (3HP)
油壓壓力	Operation Pressure	mpa	7mpa 70kg / cm ²	7mpa 70kg / cm ²
油壓油容量	Oil Tank Capacity	L	約 100	約 120
氣壓壓力	Air Pressure	mpa	0.4-0.6mpa 4-6kg / cm ²	0.4-0.6mpa 4-6kg / cm ²
定寸送料方式	Feed Drive		AC 伺服馬達(1.3kw 或 1.5kw) + 精密滾珠螺桿 AC servo-motor (1.3kw or 1.5kw) and precision ball screw	
頭部驅動方式	Sawhead Drive		A. 油壓驅動進給切斷 Material feeding and cutting is driven by hydraulic system	—
			B. AC 伺服馬達(1.8kw 或 2.0kw) + 滾珠螺桿驅動進給切斷 (選配) AC Servo-motor (1.8kw or 2.0kw) + Ball screw transmission for cutting	
送料夾鉗	Feeding Vise		平行油壓式 Horizontal hydraulic type	
主夾鉗	Main Vise		平型油壓式 / 上壓油壓式各一組 Horizontal and vertical hydraulic type , one set each	
機械尺寸與重量	Machine Dimensions And			
尺寸	Machine Size	mm	6650 x 1450 x 1560	6860 x 1889 x 1530
重量(機台+料架)	Weight (Machine + Feeder)	kg	2500	2500

機型	Model		THC-B90NC	THC-BNA102NC
鋸切能力	Cutting Capacity		TCT 超硬錫鋼圓鋸片 HSS 高速鋼圓鋸片 TCT carbide sawblade HSS sawblade	TIP 鋁錫鋼圓鋸片 TIP aluminum carbide sawblade
棒材	Round Solid Bar	mm	● 15-90	● 20-101
角材	Square Solid Bar	mm	■ 15-80	■ 20-90
長方形	Rectangle	mm	▬ 15-80	▬ 20-90
圓管	Round Pipe	mm	○ 15-90	○ 20-101
方管	Square Pipe	mm	□ 15-80	□ 20-90
先端切斷長度最大	Maximum Length of Head Cut	mm	10-60	10-60
尾端殘材長度	Waste Material Length at Tail End	mm	55-(55 + π 切斷長度Cutting length)	
送料長度	Feeding Length	mm	5-600 連續循環動作Continuous cycles	
手摺排列料架承載	Manually Stack Line-up Loader Capacity	kg	3000	3000
材料長度	Material Length Mm	mm	2000-6000	2000-6000
置料長度	Material Loading Width	mm	950	950
機械規格		Machine Specifications		
TCT 超硬錫鋼圓鋸片	TCT Carbide Sawblade		Ø285 x 2.0-Ø330 x 2.25	—
銷孔+孔徑	Pin Holes + Bore	mm	4 x Ø11 x PCD63 x Ø32	—
TIP 鋁錫鋼圓鋸片	TIP Aluminum Carbide Sawblade	mm	—	Ø305-Ø335 (t2.2-3.0 Std. 標準)
銷孔+孔徑	Pin Holes + Bore	mm	—	4 x Ø11 x PCD63 x Ø25.4 (Ø32 Opt. 選配)
HSS 高速鋼圓鋸片	HSS Sawblade	mm	Ø285-Ø330 / t2.0-2.5	—
主軸馬達	Spindle Motor	kw	9 (12HP)	11 (15HP)
主軸轉速	Spindle Speeds	rpm	50-180	2600-3500
變頻器	Frequency Inverter	kw	11 (15HP)	11 (15HP)
油壓馬達	Hydraulic Pump Motor	kw	2.2 (3HP)	2.2 (3HP)
油壓壓力	Operation Pressure	mpa	7mpa 70kg / cm ²	7mpa 70kg / cm ²
油壓油容量	Oil Tank Capacity	L	約 120	約 120
氣壓壓力	Air Pressure	mpa	0.4-0.6mpa 4-6kg / cm ²	0.4-0.6mpa 4-6kg / cm ²
定寸送料方式	Feed Drive		AC 伺服馬達(1.3kw 或 1.5kw) + 精密滾珠螺桿 AC servo-motor(1.3kw or 1.5kw) and precision ball screw	
頭部驅動方式	Sawhead Drive		AC 伺服馬達(1.8kw 或 2.0kw) + 精密滾珠螺桿驅動進給切斷(選配) AC servo-motor(1.8kw or 2.0kw) + Precision ball screw transmission for cutting (Opt.)	
送料夾鉗	Feeding Vise		平行油壓式 Horizontal hydraulic type	
主夾鉗	Main Vise		平行油壓式 / 上壓油壓式各一組 Horizontal and vertical hydraulic type , one set each	
機械尺寸與重量		Machine Dimensions and Weight		
尺寸	Machine Size	mm	6860 x 1889 x 1530	6860 x 1889 x 1530
重量(機台+料架)	Weight (Machine + Feeder)	kg	2800	2800

THC-A101NC THC-B101NC	THC-A130NC THC-B130NC	THC-A150NC THC-B150NC	THC-A165NC THC-B165NC	THC-NA168NC THC-BNA168NC
TCT超硬鎢鋼圓鋸片 HSS高速鋼圓鋸片 TCT carbide sawblade HSS sawblade	TCT超硬鎢鋼圓鋸片 HSS高速鋼圓鋸片 TCT carbide sawblade HSS sawblade	TCT超硬鎢鋼圓鋸片 TCT carbide sawblade sawblade		TIP 銅鋁鎢鋼圓鋸片 TIP aluminum carbide
● 25-100 ■ 25-76 ■ 25-76 ○ 25-100 □ 25-76	● 25-130 ■ 25-110 ■ 25-110 ○ 25-130 □ 25-110	● 50-150 ■ 50-110 ■ 50-100 — — — —	● 70-165 ■ 70-130 ■ 80-120 ○ 70-168 □ 70-130	● 70-168 ■ 70-130 ■ 80-120
10-50	10-50	10-50	10-50	10-50
85-(85 + π 切斷長度Cutting length) 5-640 連續循環動作Continuous cycles		85-(85 + π 切斷長度Cutting length) 5-640 連續循環動作Continuous cycles		
3600	3600	4600	4600	4600
3000-6000 900	3000-6000 900	3000-6000 900	3000-6000 900	3000-6000 900
Ø360 x 2.3 x 12.6 (t2.5-2.7)	Ø425 x 2.3 x 12.7 (t2.5-2.7 Std. 標準) Ø360 x 2.3 x 12.6 (t2.5-2.7 Opt. 選配)	Ø460 x 2.3 x 12.7 Ø460 x 2.3 x 12.7 (Opt. 選配)	Ø480 x 2.3 x 12.7 (Std. 標準)	—
4 x Ø14 x PCD80 & 4 x Ø11 x PCD63 x Ø32 / Ø40 / Ø50		4 x Ø21 x PCD90 x Ø50	4 x Ø21 x PCD90 x Ø50	—
— —	— —	— — — —	Ø480 x 12.7-3.6 4 x Ø21 x PCD90 x Ø32	
Ø360 x 12.5-3.5	Ø360-Ø425 x 12.5-3.5	— —	—	
4 x Ø11 x PCD63 x Ø32 / Ø40 / Ø50		—		
11 (15HP) 12-120 15 (20HP)	11 (15HP) 12-120 15 (20HP)	11 (15HP) 30-90 15 (20HP)	11 (15HP) 30-90 15 (20HP)	15 (20HP) 1300-3400 18.5 (25HP)
3.7 (5HP) 7mpa 70kg / cm ² 約 150 0.4-0.6mpa 4-6kg / cm ²	3.7 (5HP) 7mpa 70kg / cm ² 約 150 0.4-0.6mpa 4-6kg / cm ²	3.7 (5HP) 7mpa 70kg / cm ² 約 150 0.4-0.6mpa 4-6kg / cm ²	3.7 (5HP) 7mpa 70kg / cm ² 約 150 0.4-0.6mpa 4-6kg / cm ²	3.7 (5HP) 7mpa 70kg / cm ² 約 150 0.4-0.6mpa 4-6kg / cm ²
AC 伺服馬達(1.8kw 或 2.0kw) + 精密滾珠螺桿 AC servo-motor(1.8kw or 2.0kw) and precision ball screw		AC 伺服馬達(1.8kw 或 2.0kw) + 精密滾珠螺桿 AC servo-motor(1.8kw or 2.0kw) and precision ball screw		
A. 油壓驅動進給切斷 Material feeding and cutting is driven by hydraulic system B. AC伺服馬達(2.9kw 或 3.5kw) + 精密滾珠螺桿驅動進給切斷 (選配) AC Servo-motor(2.9kw or 3.5kw) + Precision ball screw transmission for cutting (Opt.)		A. 油壓驅動進給切斷 Material feeding and cutting is driven by hydraulic system B. AC伺服馬達(2.9kw 或 3.5kw) + 精密滾珠螺桿驅動進給切斷 (選配) AC Servo-motor(2.9kw or 3.5kw) + Precision ball screw transmission for cutting (Opt.)		
平行油壓式 Horizontal hydraulic type		平行油壓式 Horizontal hydraulic type		
平型油壓式 / 上壓油壓式各一組 Horizontal and vertical hydraulic type , one set each		平型油壓式 / 上壓油壓式各一組 Horizontal and vertical hydraulic type , one set each		
6700 x 2200 x1900	6700 x 2200 x1900	6700 x 2200 x1900	6700 x 2200 x1900	6700 x 2200 x1900
3500 + 1500	3500 + 1500	4000 + 1600	4000 + 1600	4000 + 1600



THC
SERIES

鋒和機械

Fong Ho Machinery

圓鋸切斷機專業製造

Circular Sawing Machine Professional Manufacture

台灣總公司

鋒和機械工業股份有限公司

台灣省台中市大里區文心南路1191巷12號

Fong Ho Machinery Industry Co.,Ltd.

Tel: 886-4-2406-6769 Fax: 886-4-2406-8858

No. 12, Lane 1191, Wen-Shin South Road,
Tali Dist., Taichung City 41258, Taiwan

www.fongho.com.tw fongho@ms26.hinet.net



中國CHINA
臺灣TAIWAN

中國工廠 台資企業

鋒和機械(張家港)有限公司

中國江蘇省張家港市南豐經濟技術開發區204國道南豐段015號

Fong Ho Machinery (Zhang Jia Gang) Co.,Ltd.

Tel: 0512-5827-0871 Fax: 0512-5827-0876

Tel: 0512-5827-0872 Fax: 0512-5827-0869

No. 015, Nanfeng Segment, 204 Guodao Road,
Economic Development Zone, Zhang Jia Gang,
Jiang Su Province, China

www.fongho.com.cn gsmachine@163.com

中國營銷服務處

廣東 Tel: 0769-8531-3418 Fax: 0769-8531-3419

北京 Tel: 0316-332-2189 Fax: 0316-599-2698

上海 Tel: 021-5437-6048 Fax: 021-5437-6049

寧波 Tel: 0574-8715-6528 Fax: 0574-8715-6875

昆山 Tel: 0512-5737-2050 Fax: 0512-5737-2051

廈門 Tel: 0592-638-6223 Fax: 0592-638-6225

Agents