



I-9120

1-port CAN Programmable Module

Features

- Support WP-9x21-CE7 (driver for LinPAC and XPAC will be Available Soon)
- Allow user to program user-defined firmware in I-9120
- 2500 Vrms photo-isolation protection on CAN side
- Compatible with CAN specification 2.0 parts A and B
- Provide default baud rate: 10k, 20k, 50k, 125k, 250k, 500k, 800 k, 1 M bps
- Allow user-defined baud rate
- Utility tool for downloading user-defined firmware and updating default firmware
- Provide eVC++4.0, VC6, VC++ 2005, C#.net 2005, VB.net 2005 demos and library



Introduction

The CAN (Controller Area Network) is a serial communication bus especially suited to interconnect smart devices to build smart systems or sub-system. It efficiently supports distributed real-time control with a very high level of security. In CAN networks, there is no addressing of subscribers or stations in the conventional sense, but instead prioritized messages are transmitted. As standalone CAN controller, I-9120 with WinPAC-9000-CE7 series MCU (main control unit) represents an economic solution. It has one CAN communication port with 5-pin screw terminal connector, and is useful for a wide range of CAN applications. Besides, I-9120 uses the new Phillips SJA1000T and transceiver 82C250, which provide both CAN 2.0A and 2.0B specific, re-transmission function, bus arbitration and error detection. Combining the benefits of WinPAC-9000-CE7 series MCU without increasing the CPU loading heavily, it could be a powerful multi CAN port programmable device server by driving the program in the 186 CPU of I-9120. It can also communicate with other kinds of communication interface, such as RS-232/RS-485/Ethernet ports to be a programmable device server. Therefore, users can design the various applications between different communication protocols.

Applications

Energy Storage System

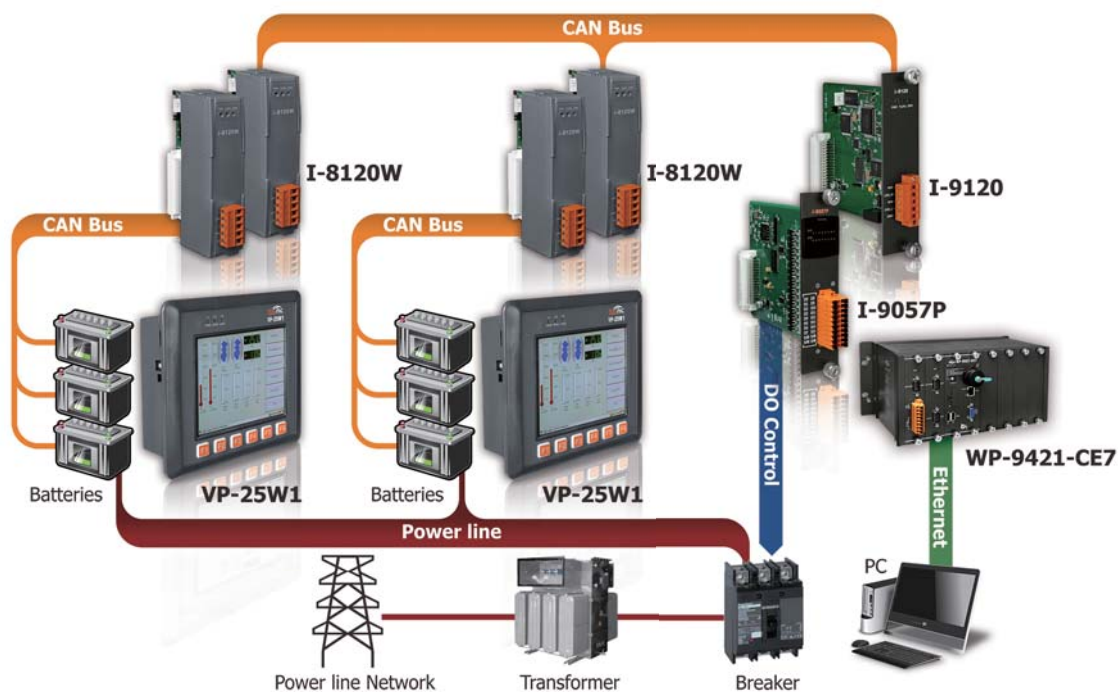

Specifications

Hardware	
CPU	80186, 80 MHz or compatible
SRAM/Flash/EEPROM	512 KB / 512 KB / 16 KB
DPRAM	8 KB
Watchdog	Watchdog IC
ESD Protection	2 kV class A
CAN Interface	
Controller	NXP SJA1000T with 16 MHz clock
Transceiver	NXP 82C250
Connector	5-pin screw terminal block (CAN_GND, CAN_L, CAN_SHLD, CAN_H, N/A)
Baud Rate (bps)	10 k, 20 k, 50 k, 125 k, 250 k, 500 k, 800 k, 1 M (allow user-defined baud rate)
Isolation	3000 VDC for DC-to-DC, 2500 Vrms for photo-couple
Terminal Resistor	Switch for 120 Ω terminal resistor
Specification	ISO-11898-2, CAN 2.0A and CAN 2.0B
LED	
Round LED	PWR LED, RUN LED, ERR LED
Software	
Driver	WP-9000-CE7
Library	TC/BC/TC++/BC++, eVC++ 4.0, VC++ 2005, C#.net 2005, VB.net 2005
Power	
Power supply	Unregulated +10 ~ +30 VDC
Protection	Power reverse polarity protection, Over-voltage brown-out protection
Power Consumption	1.5 W
Mechanism	
Dimensions	31mm x 134mm x 144mm (W x L x H)
Environment	
Operating Temp.	-25 ~ 75 $^{\circ}$ C
Storage Temp.	-30 ~ 80 $^{\circ}$ C
Humidity	10 ~ 90% RH, non-condensing

Ordering Information

I-9120	1-port Programmable CAN Module (Parallel Bus Type) (RoHS)
---------------	---

Accessories

CA-0904	4-pin connector & 9-pin Female D-sub cable, for CAN/Profibus (300V)
----------------	---

Pin Assignments

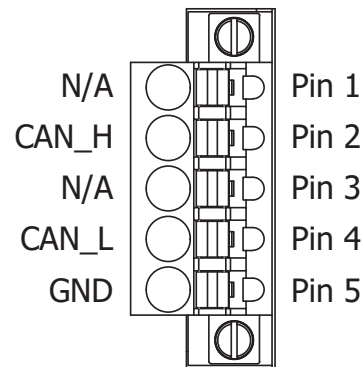

Pin No.	Signal	Description
1	N/A	Non-available
2	CAN_H	CAN_H bus line (dominant high)
3	N/A	Non-available
4	CAN_L	CAN_L bus line (dominant low)
5	GND	CAN ground

Dimensions (Units: mm)

