



General Description:

The Culinaire® Banquet Cart uses a unique heating system that incorporates gentle radiant heat. The gentle radiant heat prevents food from drying out, which can happen in standard designs or those with fan-forced circulation. There is no water required and because the food is retaining its natural moisture it maintains flavour and consistency.

With fully sealed interiors and concealed elements, the carts are hygienic and easy to clean.

Model:

Code: CH.CBC.1211

Code explanation:

CH = Culinaire Heated
CBC = Culinaire Banquet Cart
1211 = Capacity = 12 x 1/1 GN pans or
or 6 x 2/1 GN pans

e.g.: for specification and ordering

Culinaire: **CH.CBC.1211**

www.TotalCommercialEquipment.com.au 08 8363 5282



Features and Benefits:

- Mobile cart with gentle heating system utilising evenly heated aluminium internal panels for long term food holding capacity
- Venting system for holding moist or crisp product
- Removable silicone gasket to cabinet face for ease of cleaning and reduced risk of damage by trays and racks
- Full stainless steel interiors including easy clean-out base
- Sturdy stainless steel pull/push handles to both sides means cart can be easily moved by two staff together
- Supplied with plug and lead, with plug tidy to hold plug neatly in place when not in use
- Non marking bumpers to base, preventing accidental damage to the cart or walls and furniture
- Large non marking castors for easy manoeuvrability
- Easy open lockable handle
- Includes 4 x 2/1 GN sized chrome plated shelves and 6 pairs of tray slides
- Full digital controls with easy to see temperature readout compliant to HACCP standards
- 304 grade stainless steel construction throughout for exceptional longevity – unlike units with corrodible steel frames

Due to continuous product research and development, the information contained herein is subject to change without notice

Specification:

Construction:

- 304 grade 1.2mm stainless steel in No.4 satin finish
- Double skinned construction, insulated on all sides
- Supplied with 4 chrome plated steel wire shelves
- Heavy-duty 125mm castors with brakes to two castors
- Heavy-duty latch and hinges

Controls:

- On/Off switch with indicator light
- Thermostatically controlled elements
- Digital controller

Electrical:

- Unit supplied with plug and lead

Product Details:

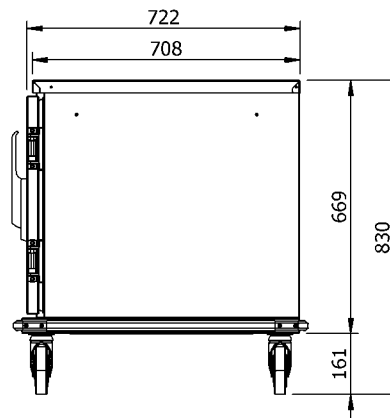
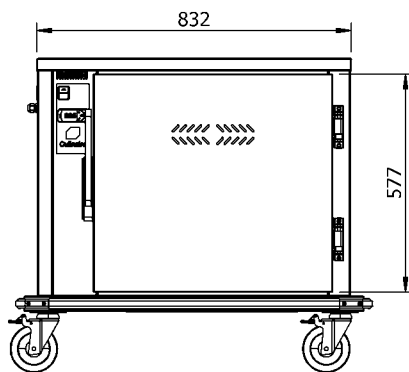
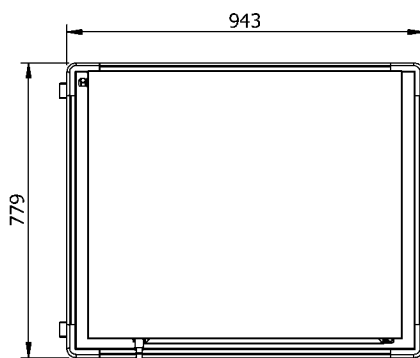

www.TotalCommercialEquipment.com.au 08 8363 5282



Technical Data:

Model	Power	Packaged Size
CH.CBC.1211	240v 1Ø 3.5A 840w	1032 x 922 x 1030

Due to continuous product research and development, the information contained herein is subject to change without notice