

1.0	machine connection: drain connection hose, DN 22 hose fitted as odour trap in interior of machine
1.1	drain (max. 750 mm above finished floor level), DN 50
2.0	Machine connection: fresh water supply, G 3/4"
2.2	Soft cold water 10°C, DN 15, G 3/4 a max. 0,54 mmol/l CaCO ₃ (max. 3°dH) Flow rate: min. 8 l/min electrical conductivity 70 - 1000 µS/cm Minimum flow pressure: 100 kPa / 1.0 bar in front of solenoid valve Maximum pressure: 500 kPa / 5.0 bar in front of pressure reducer stopcock and fine screen ≤ 25 µm
3.0	Machine connection: electrical connection cable 5G 10mm ²
3.1	electricity supply to the machine: 3N PE 400V ~ 50Hz nominal current / - capacity: 31.0 A / 20.1 kW Fuse protection: 32 A ⚡ Voltage equalising cable The master switch must be provided on site
	Note: Electrical equipment suitable for supply voltage: 3N PE 380-415 V 50 Hz / 1N PE 220-240 V 50 Hz
6.0	Heat load of warewash area The values apply for the following room conditions: Room temperature 22 °C, rel. humidity 55 % ☒ Recommended suction area according to German EN 16282 or any local regulations have to be observed to determine ventilation of wash areas The total heat load includes 6.1
6.1	Heat load of the machine in normal washing operation: for 25 programme cycles/h total 3.0 kW, perceptible 2.6 kW, latent 0.4 kW
	For the total space load, all other space loads must be considered. The space ventilation must be designed in accordance with EN 16282.

all cables, pipes etc leaving machine 1,0 m

the position of the connection piping can also be mirror-inverted!

Machine Equipment

- (A) Entry height
- (D) Rinse agent pipe and suction lance
- (E) Detergent dosing unit with suction lance
- Automatic hood system
- Automatic basket detection
- AirConcept (Exhaust air heat recovery)
- Feeding table on site
- Discharge table on site
- GiO MODULE (integrated) M2
- GiO pre-filter on the right-hand side of the machine

⚠ Please observe the installation indications of the additional document MP_T-INFO-GIO_M2_M-iClean-H_EN.pdf

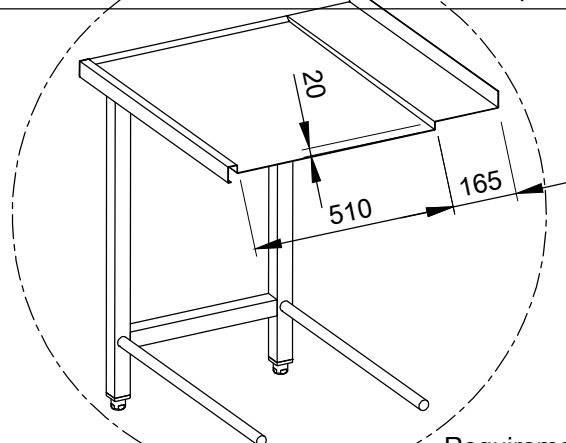

Requirement for local table profile

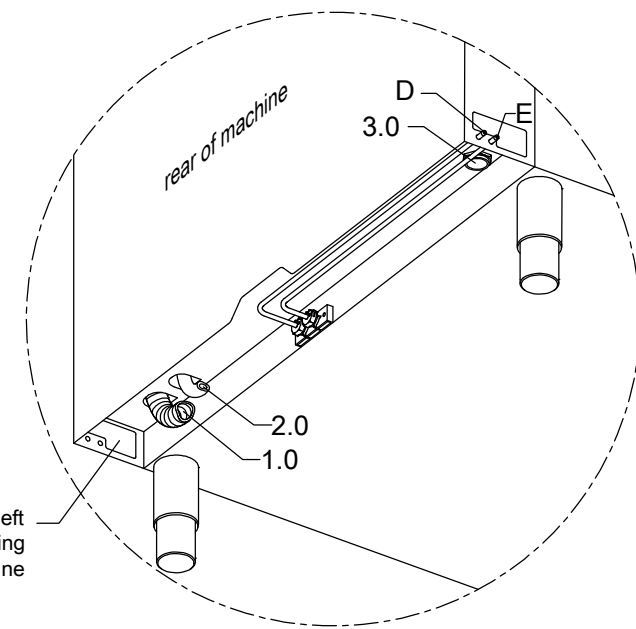
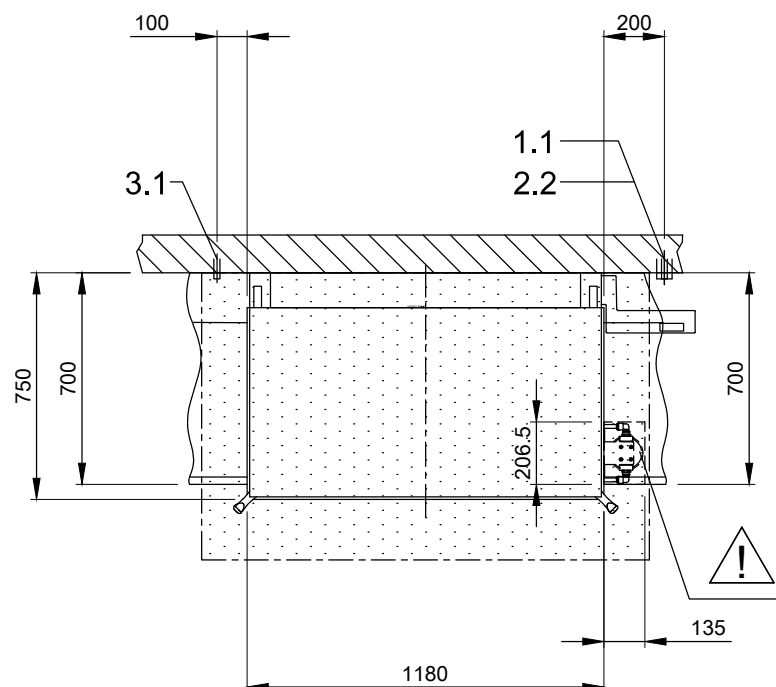
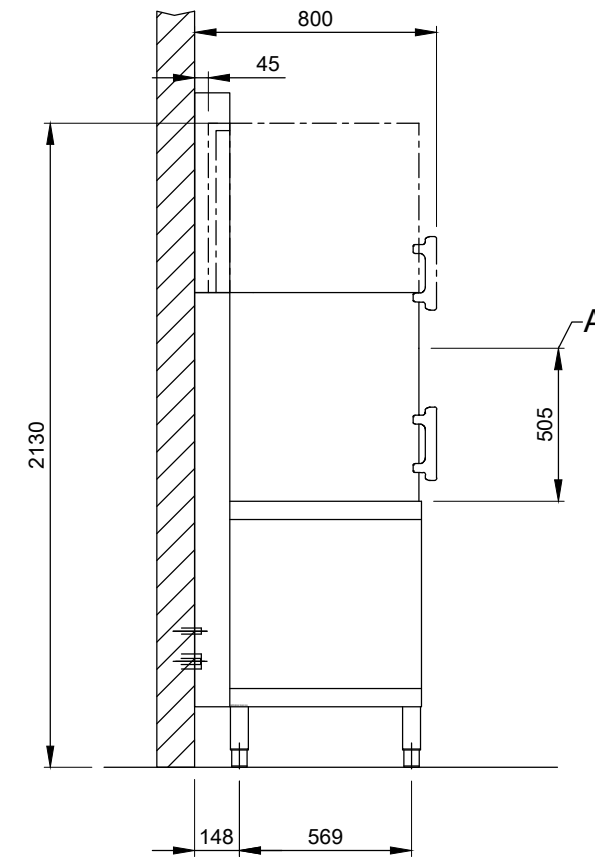
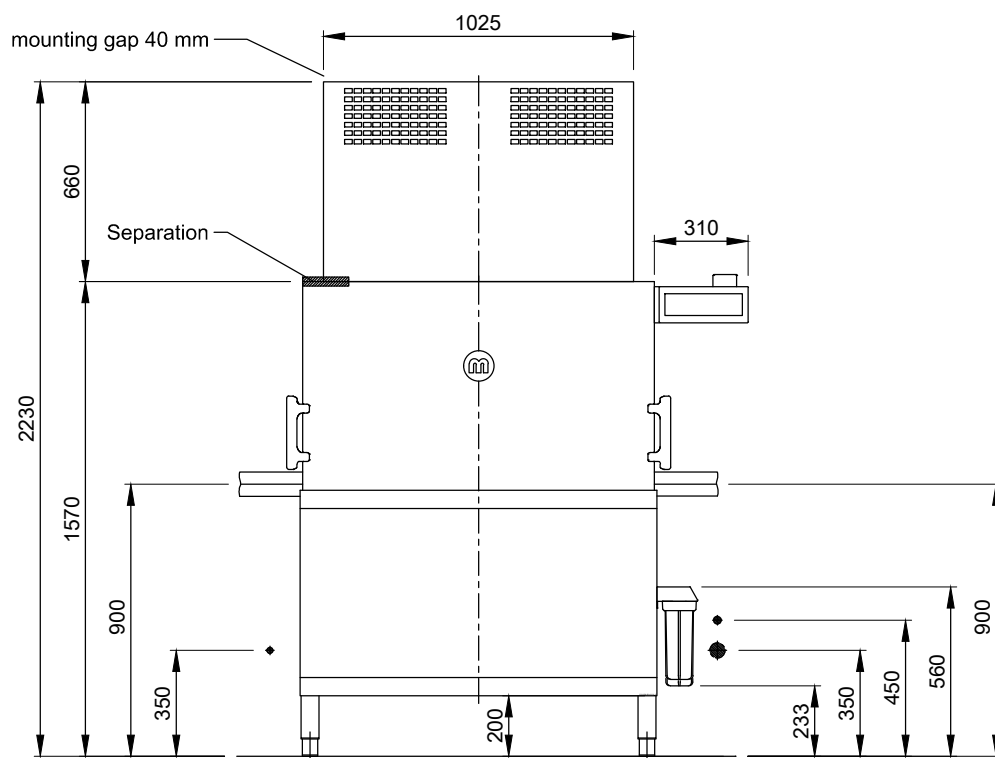

MEIKO Australia-Pacific Pty Ltd
Unit 4, 72 - 74 Gibbes Street
Chatswood NSW 2067
TEL. +61-1300 367 730, Telefax +61-1300 656 420
E-MAIL: info@meiko.com.au

This drawing may not be neither passed to third parties for their information or copied or used for competitive purposes without our consent. All rights reserved. We reserve the right to make changes resulting from technical progress. This drawing was computer generated and is not subject to the checking and any release process; it is also not subject to change management.
Please note:
This document is only valid in conjunction with the conditions defined in Supplementary Sheet "Important Information". These can be requested from the manufacturer or downloaded from the Partnernet.

Revision			
Reference	DISHWASHER STANDARD DRAWING / AUS		Type M-ICLEAN HXL M2 GIO MODULE, INTEGRATED
TYPE: CROCKERY	Drawing-No. S00119626		Order-No.
Scale 1:25	drawn: 01.09.2021	m-iplan	checked: 01.09.2021 m-iplan