

# EZ36

## Tracked Zero Tail Excavators



**WACKER  
NEUSON**  
*all it takes!*



### Trimmed for productivity

The EZ36 is full of detailed solutions that increase productivity and make working for the operator even more enjoyable and efficient. The intuitive operating concept, combined with precise control, shortens working cycles and saves time and money. In addition, many options can be installed ex factory.

- Performance meets maximum efficiency
- User-friendly operating concept and comfort cabin
- VDS - Working in the slope - without coming to falter
- Zero Tail - when it gets tight
- Unrestricted maintenance and service access



hire



sales



parts



service

[conplant.com.au](http://conplant.com.au) | 1300 166 166

## EZ36 Technical specifications

	EZ36 - level III / Tier IV i	EZ36 - Tier IV final
<b>Operating data</b>		
Shipping weight min. kg	3,530	3,530
Operating weight kg	3,720 - 4,636	3,720 - 4,636
Biting force max. kN	21.1	21.1
Breakout force max. kN	35	35
Digging depth max. (long dipperstick) mm	3,497	3,497
Dumping height mm	3,336 - 3,336	3,336 - 3,336
Digging radius max. (long dipperstick) mm	5,743	5,743
Superstructure slewing speed 1/min	9.5	9.5
L x W x H mm	5,503 x 1,750 x 2,491	5,503 x 1,750 x 2,491
<b>Engine / Motor</b>		
Engine / Motor manufacturer	Yanmar Diesel engine	Yanmar Diesel engine
Engine / Motor type	3TNV88-BPWN	3TNV88F-EPWN
Engine / Motor	water-cooled 3-cylinder suction engine	water-cooled 3-cylinder suction engine
Displacement cm <sup>3</sup>	1,642	1,642
RPM / speed rpm	2,500	2,430
Engine performance POWER Mode kW	22.2	18.2
Engine performance ECO mode kW		17.8
Battery Ah	71	71
Fuel tank capacity l	44	44
<b>Hydraulic system</b>		
Duty pump	2 axial piston pumps / 2 gear pumps	2 axial piston pumps / 2 gear pumps
Max. flow rate l/min	42.5 + 42.5	42.5 + 42.5
Max. flow rate l/min	23.8 + 11.3	23.8 + 11.3
Operating pressure for working and driving hydraulics bar	240	240
Operating pressure Drehwerk bar	195	195
<b>Undercarriage</b>		
Travel speed max. km/h	4.7	4.7
Chain width mm	300	300
Ground clearance mm	251	251
<b>Dozer Blade</b>		
Width mm	1,750	1,750
Height mm	357	357
Stroke dozer blade above ground mm	393	393
Stroke dozer blade below ground mm	505	505



hire



sales



parts



service

conplant.com.au | 1300 166 166

## EZ36 Dimensions

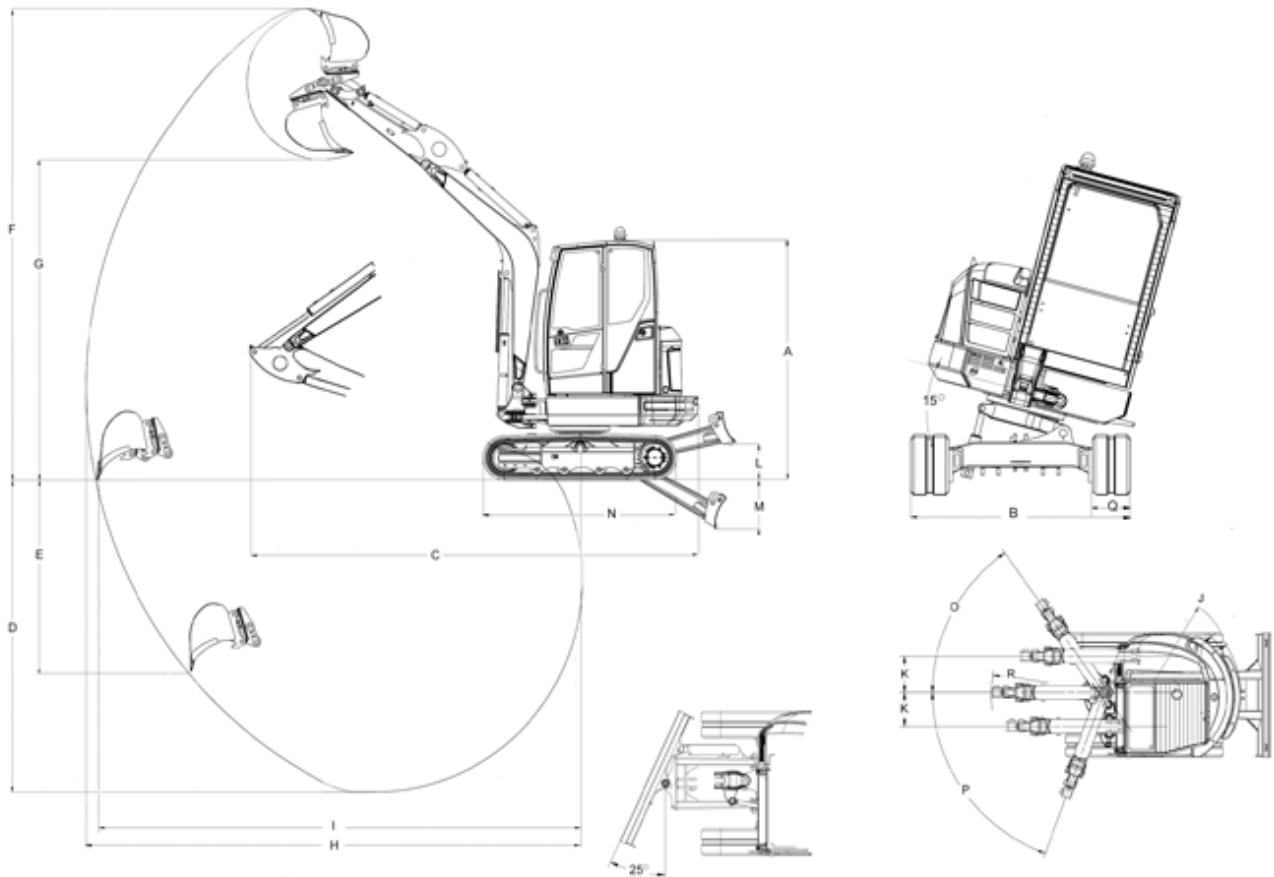

VDS

A	Height	2,491 mm	2,573 mm
B	Width	1,750 mm	1,750 mm
Q	Width undercarriage	300 mm	300 mm
C	Transport length	5,503 mm	5,489 mm
D	Digging depth max. (short dipperstick)	3,247 mm	3,172 mm
D	Digging depth max. (long dipperstick)	3,497 mm	3,422 mm
E	Insertion depth max. vertical (short dipperstick)	2,123 mm	2,048 mm
E	Insertion depth max. vertical (long dipperstick)	2,360 mm	2,285 mm
F	Insertion height max. (short dipperstick)	4,925 mm	5,004 mm
F	Insertion height max. (long dipperstick)	5,082 mm	5,157 mm
G	Dump height max. (short dipperstick)	3,336 mm	3,411 mm
G	Dump height max. (long dipperstick)	3,489 mm	3,564 mm
H	Digging radius max. (short dipperstick)	5,298 mm	5,270 mm
H	Digging radius max. (long dipperstick)	5,582 mm	5,546 mm
I	Range on the ground max. (short dipperstick)	5,391 mm	5,378 mm
I	Range on the ground max. (long dipperstick)	5,641 mm	5,629 mm
J	Rear swivel radius min.	933 mm	933 mm
K	Arm displacement max. to center bucket right side	680 mm	680 mm



hire



sales



parts



service

conplant.com.au | 1300 166 166

K	Arm displacement max. to center bucket left side	650 mm	650 mm
L	Lift height max. dozer blade above ground	393 mm	393 mm
M	Scraping depth max. dozer blade below ground	505 mm	505 mm
N	Length undercarriage	2,062 mm	2,062 mm
O	Turning angle max. boom to the right	45 °	45 °
P	Turning angle max. boom to the left	70 °	70 °
--	Boom slewing radius center	2,245 mm	2,245 mm

Please note: that product availability can vary from country to country. It is possible that information / products may not be available in your country. More detailed information on engine power can be found in the operator's manual; the stated power may vary due to specific operating conditions. Subject to alterations and errors excepted. Applicable also to illustrations.  
 Copyright © 2019 Wacker Neuson SE.



hire



sales



parts



service

[conplant.com.au](http://conplant.com.au) | 1300 166 166