



# ExactWeld 230

## High-Precision Laser Welding

Our new line of laser welding machines provides a cost-effective solution for high-precision welding applications. It is an ideal tool for scanner welding of small to medium sized metal parts. Typical applications are in automotive production, electronics, and medical device manufacturing. This new line of laser machines features a wide assortment of scanner heads for the most challenging, precision-welding applications, and motorized X/Y/Z axes. The systems are powered by our latest fiber laser technology and provide low cost of ownership through high productivity and enhanced ease-of-use. They are backed by our outstanding applications and global service support infrastructure.



### FEATURES & BENEFITS

- High-productivity precision welding system with patented SmartWeld™ technology
- Powered by latest fiber laser technology
- Class 1 laser housing meets the newest ergonomic guidelines
- Welded steel construction base frame
- High process consistency
- Industry 4.0 ready
- Servo motor with X/Y/Z axis travel
- Large working chamber
- Pneumatic lifting door and rotary table available

### APPLICATIONS

- Welding of Metals

TECHNICAL SPECIFICATIONS		ExactWeld 230
Interface	Display and Operation Data Interfaces	24" screen + keyboard USB device, RJ45 connection
INSTALLATION		
Dimensions (L x W x H)		1700 x 1000 x 2050 mm (66.9 x 39.4 x 80.7 in.)
Weight		1100 kg (2425.5 lbs.)
Maximum Payload		100 kg (220.5 lbs.)
ELECTRIC		
Energy (VAC)		400
Frequency (Hz)		50/60
Current (A)		16
POWER CONSUMPTION		
Effective Power (kW)		1.4
Standby (kW)		0.8
PNEUMATIC		
Compressed Air		6 bar
INSTALLATION CONDITIONS		
Laser Safety Class (according to EN60825-1:2015)		Laser Class 1
Description		As seated and standing workplace available (worktable or rotary table)



AXIS SYSTEM	
X/Y/Z-Axis Travel (mm)	400 x 400 x 300 mm (15.75 x 15.75 x 11.8 in.)
Drive	Servo motor with ballscrew
Positioning Accuracy (mm)	0.06   0.06   0.1
Repeatability Accuracy (mm)	0.01   0.01   0.01
Several Axis variants available, starting from single Z-Axis up to X/Y/Z-Axis	

### INTEGRATED StarFiber

- CW fiber laser
- 200 W / 400 W
- Analog power control
- High efficiency
- Safety features (industrial standard)
- Innovative control unit



### Wide Range of Optics for Challenging Laser Fine-Welding Applications



## OPTIONS



### Rotary Axis

Direct drive rotary axis with a maximum rotating speed of 500 r/minute and a rated rotation speed of 1000 r/minute

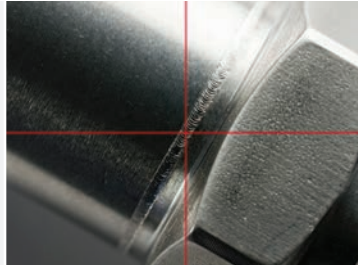

### CCD Camera

CCD camera with integrated crosshair generator for easy positioning

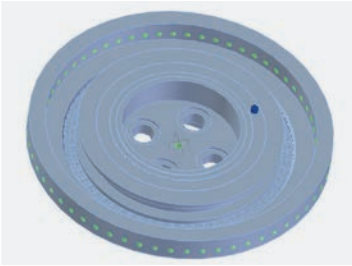

### Fixtures

Extensive know-how in part-specific workpiece holders



### Foot Switch

For a comfortable start of the CNC routine

## APPLICATIONS

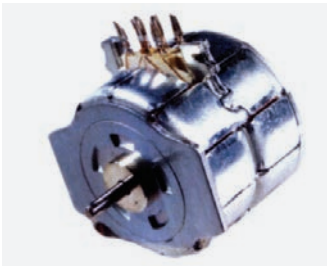

### Contact Welding

Minimum welding spots with diameters far below 0.1 mm

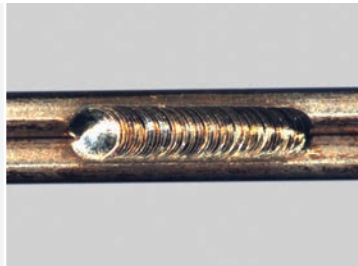

### Seam Welding

Small seam geometries at high welding speeds. The results are welds of maximal strength at minimal thermal input for the workpiece.

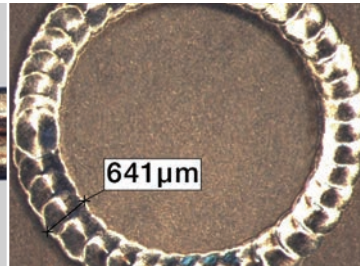

### Freeform Welding

From simple to very complex geometries. Individual designs, prototypes and single production.



### Seal Welding

No porosities and crack free seams provide for leakproof weldings

## MECHANICAL SPECIFICATIONS

### ExactWeld 230

Front View

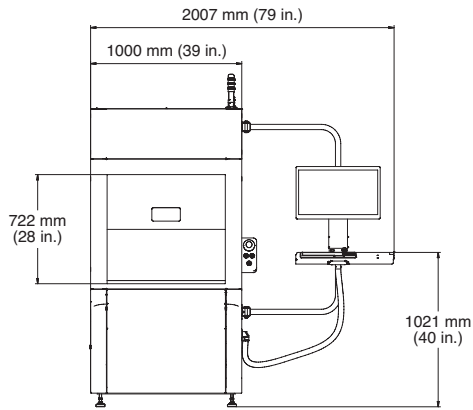

Side View

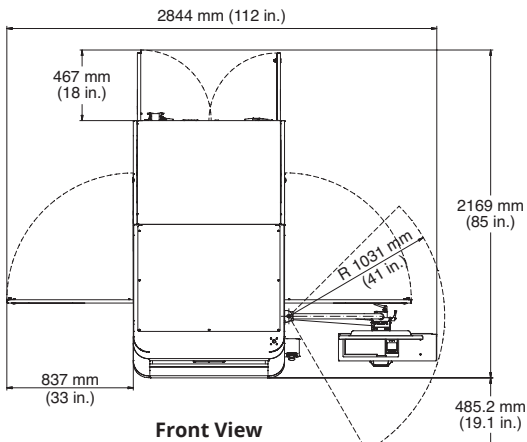
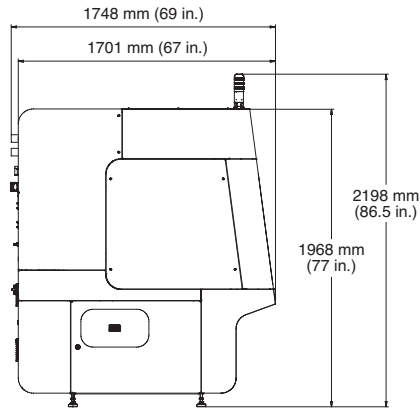

Front View

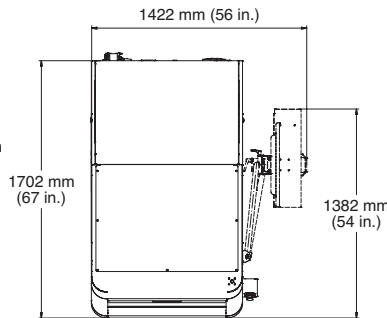

Front View for Transport

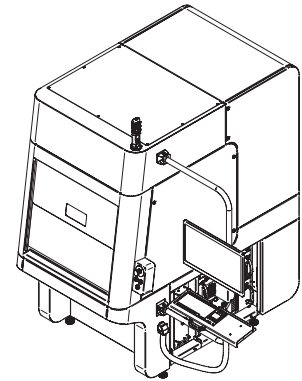

Coherent, Inc.,  
5100 Patrick Henry Drive Santa Clara, CA 95054  
p. (800) 527-3786 | (408) 764-4983  
f. (408) 764-4646

[tech.sales@coherent.com](mailto:tech.sales@coherent.com) [www.coherent.com](http://www.coherent.com)

Coherent follows a policy of continuous product improvement. Specifications are subject to change without notice. Coherent's scientific and industrial lasers are certified to comply with the Federal Regulations (21 CFR Subchapter J) as administered by the Center for Devices and Radiological Health on all systems ordered for shipment after August 2, 1976.

Coherent offers a limited warranty for all ExactWeld 230 Laser Welding Machines. For full details of this warranty coverage, please refer to the Service section at [www.Coherent.com](http://www.Coherent.com) or contact your local Sales or Service Representative. MC-015-19-0M0619 Copyright ©2019 Coherent, Inc.