



Modular bin trailer

(6 BIN MODEL)

Assembly instruction manual



Modular Bin Trailer—Assembly Instruction Manual OM0023E

This manual contains important assembly instructions for this unit. Read this manual thoroughly and completely.

Any damage audible or visible to this unit should be addressed at the time of discovery. Electrodrive Pty Ltd can provide parts and service support on request through its service partner company:

Serviced Equipment Pty Ltd

p: 1300 934 471

e: service@fallshaw.com.au

Made in Australia by:

Electrodrive Pty Ltd

2A Ayton Street, Sunshine North VIC Australia 3020

p: 1300 934 471 (within Australia)

p: +61 (03) 9300 8521 (International)

e: sales@electrodrive.com.au

w: www.electrodrive.com.au

© Electrodrive

Introduction

This Modular Bin Trailer comes flat-packed. Its sides are 50% pre-assembled.

The remaining nuts and bolts will be supplied in a sealed bag.

Please follow the assembly instructions carefully.



The flat-packed unit with three sides folded down.

Tools required:

- 10 mm spanner
- 13 mm spanner.
- Allen key set.
- x2 adjustable spanners (maximum opening of 17 mm).



Warning:

Do not tighten the screws before assembling all the components.

Do not over-tighten the screws.

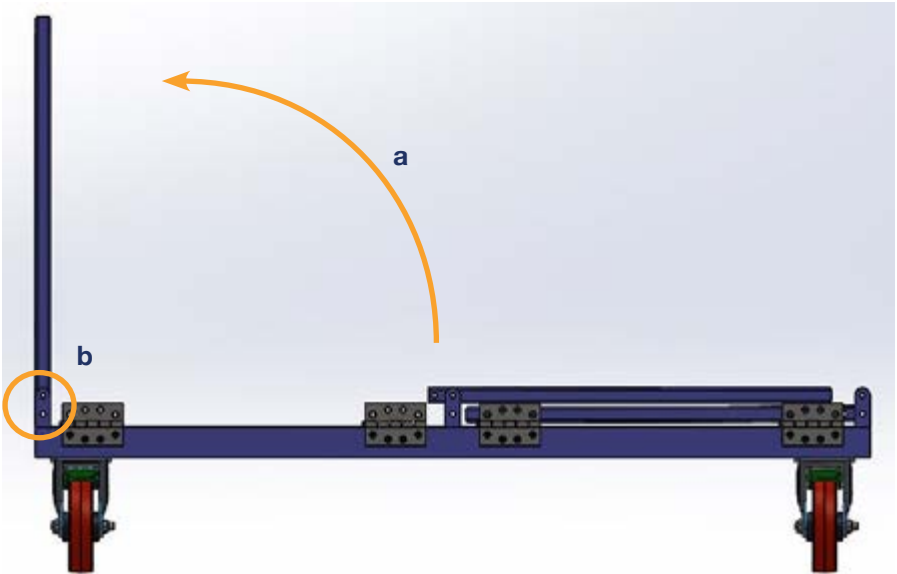

Step 1

- a. Lift the first side vertically.
- b. Use the four M8 bolts to clamp into place.



Step 2

Using the 13 mm spanner and shifter, assemble the bolts and nuts (as shown in the four circled locations in the diagram above).

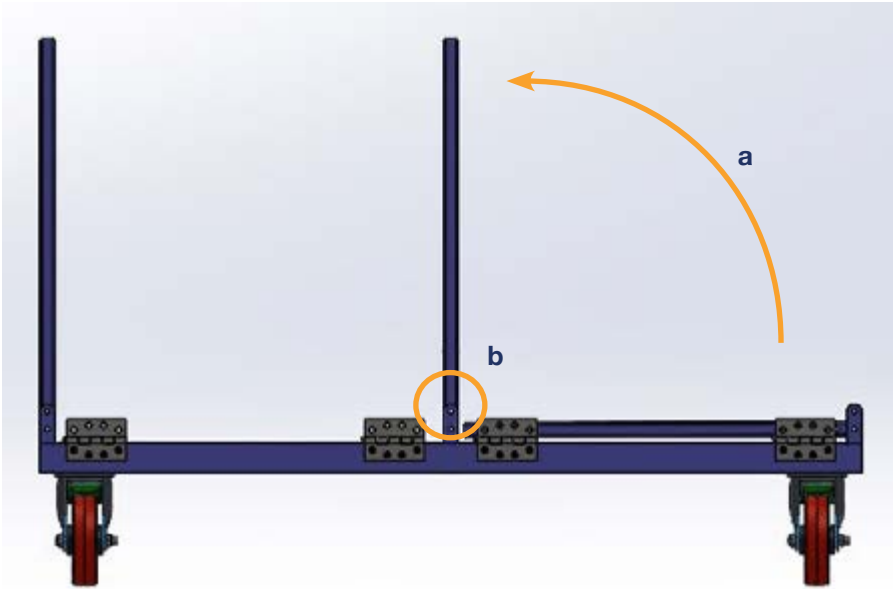

Step 3

- a. Lift the second side vertically.
- b. Assemble using the M8 bolts.



Step 4

Using the 13 mm spanner and shifter, assemble the bolts and nuts (as shown in the four circled locations in the diagram above).

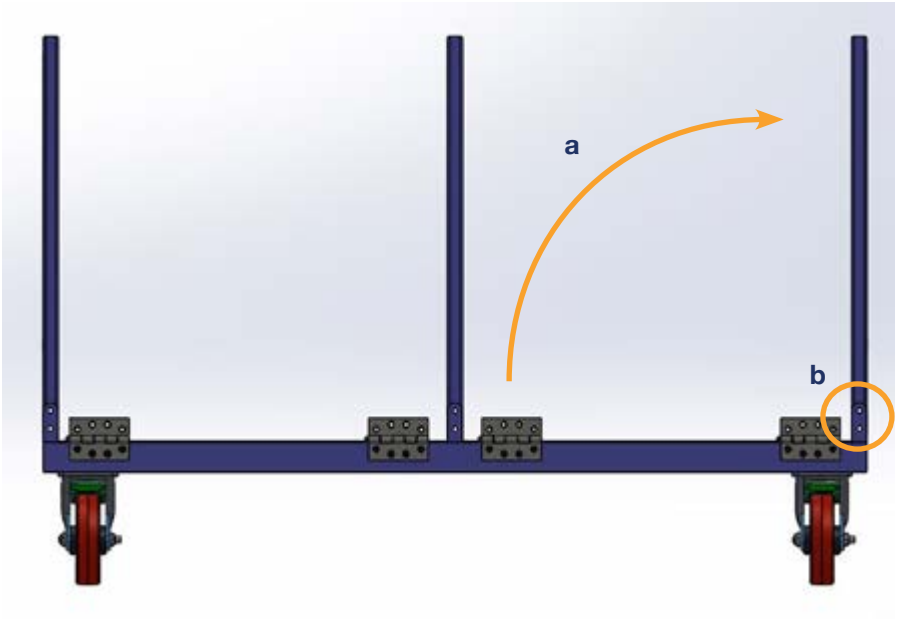

Step 5

- a. Lift the third side vertically.
- b. Assemble using the M8 bolts.

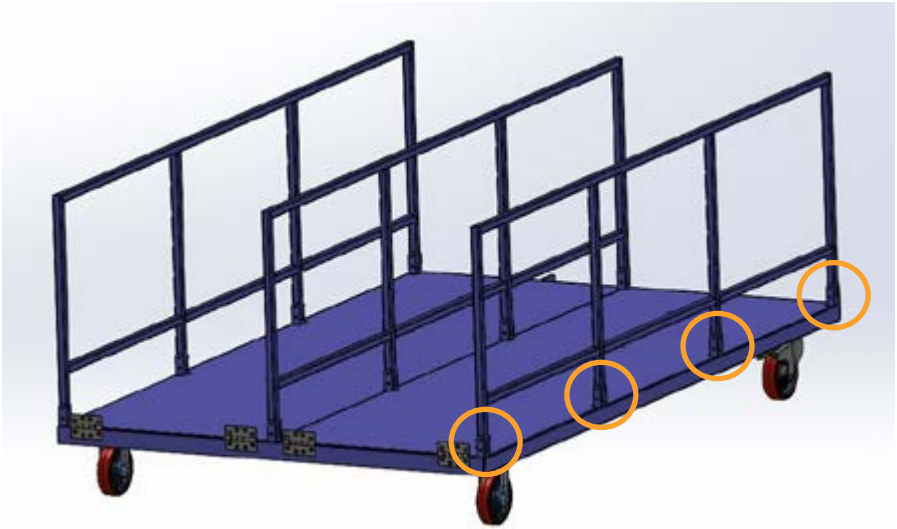

Step 6

Using the 13 mm spanner and shifter, assemble the bolts and nuts (as shown in the four circled locations in the diagram above).



Step 7

Assemble cross bar between the first and second side top and bottom. Make sure to leave enough slack to assemble the second cross bar.



Please note:

Ensure you use the correct orientation for this cross bar.

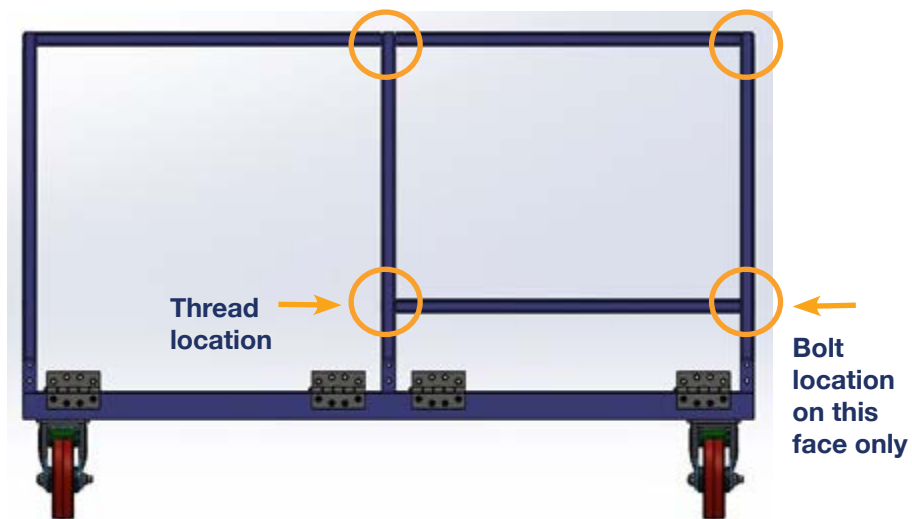

- The cross bar has a hole on one side, and thread on the other.
- Put bolt on one side only.
- The threaded portion comes with bar pre-assembled.



Step 8

Assemble the cross bar between the second and third side.

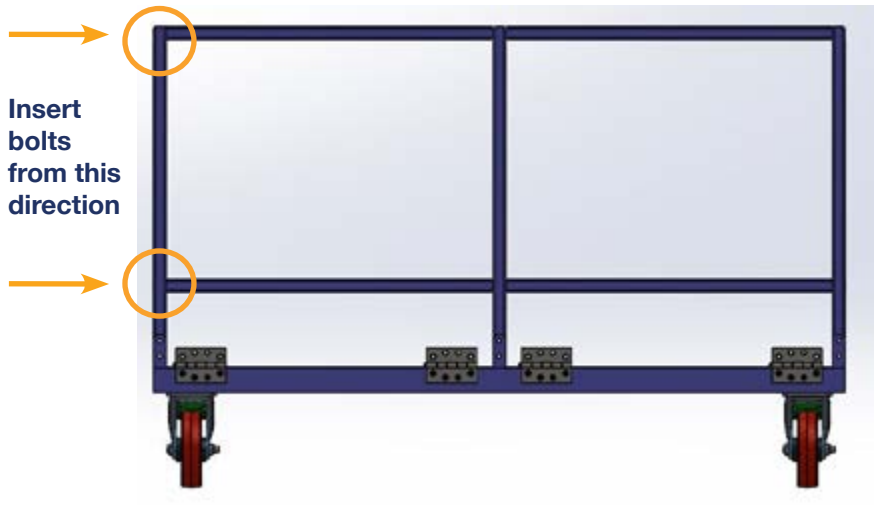

Rotate the cross bar to tighten the middle part.

The bolts comes with bar pre-assembled.

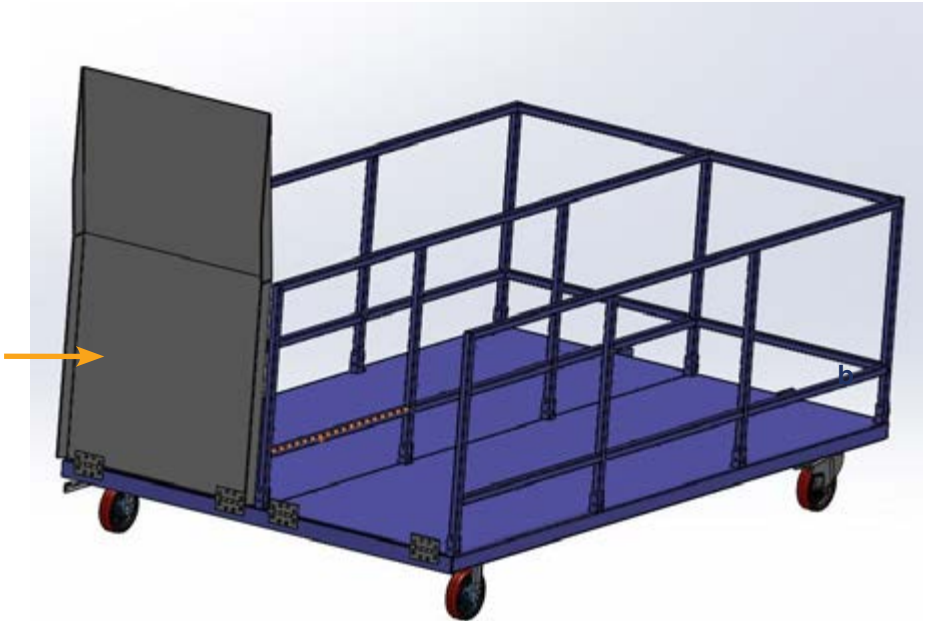

Step 9

Using the Allen keys and shifter, assemble the first ramp.

You will need:

- Screws (x 8)
- Nuts (x 8)

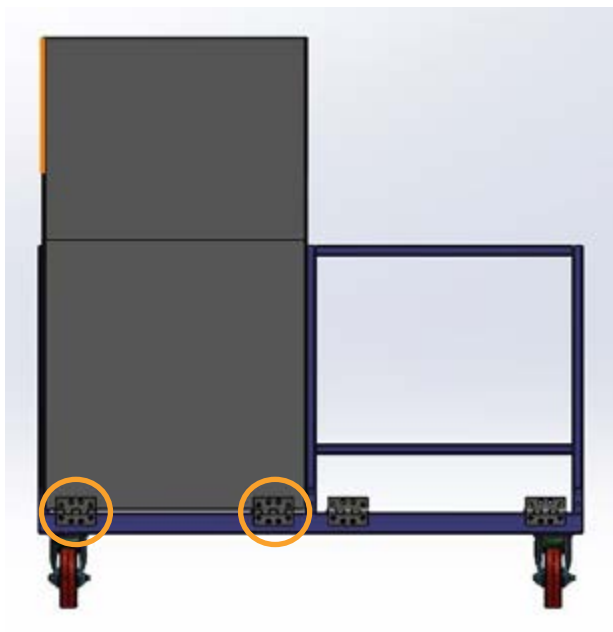

The unit comes with hinges assembled on to the base (as shown in the circled locations in the diagram above).

Use the supplied countersunk screws to assemble ramp to the hinge.



Please note:

Make sure to use the right side of the countersunk screws for assembly.

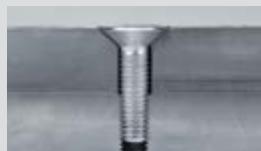

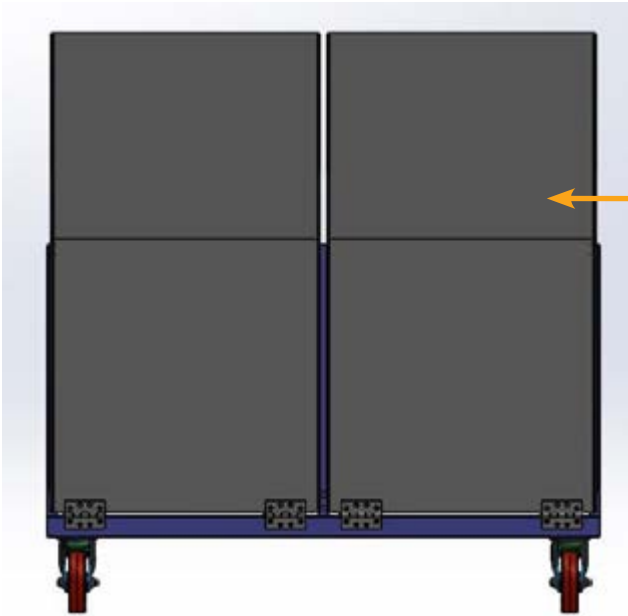

Step 10

Using the Allen keys and shifter, assemble the second ramp.

You will need:

- Screws (x 8)
- Nuts (x 8)

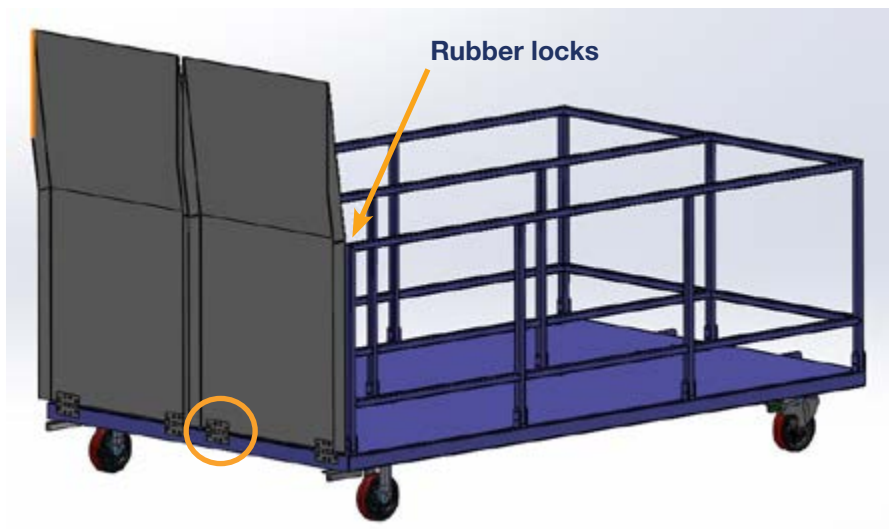

The unit comes with hinges assembled on to the base (as shown in the circled locations in the diagram above).

- Use the supplied countersunk screws to assemble ramp to the hinge.
- Use the pre-assembled rubber locks to keep it secure (as shown in the diagram above).

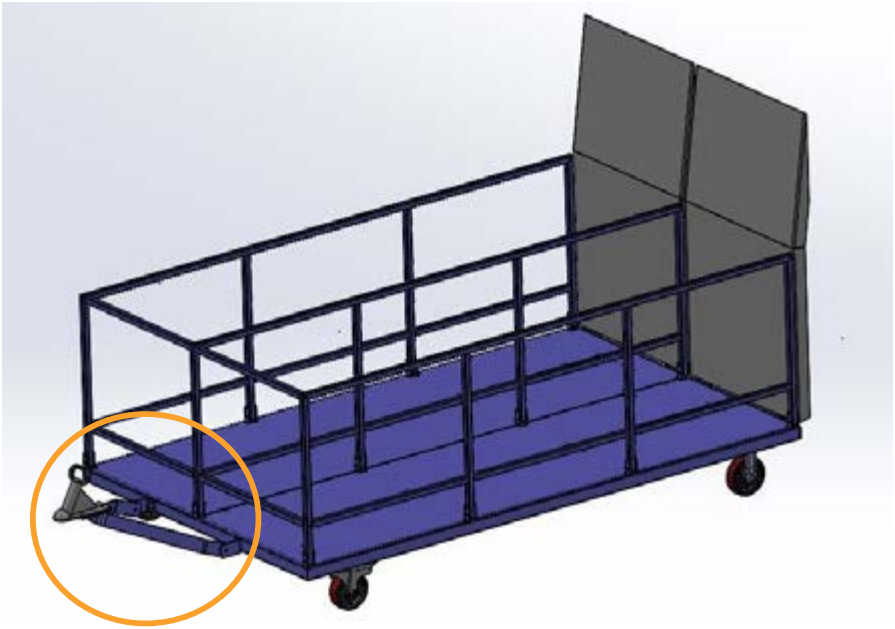

Step 11

Using the x2 M10 bolts and nuts supplied, assemble the drawbar to the base.

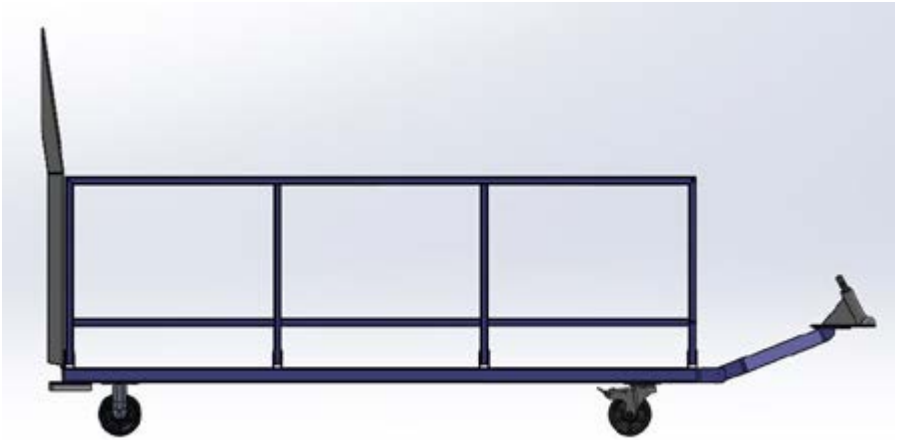

Assembly side view

Use the x3 washers in between the bracket and drawbar to avoid rubbing.



Gas strut



Bolt

Step 12

- Assemble the gas struts.
These gas struts have one side fitted to the ramp. The other side of the gas strut is pre-fitted to the base frame.
- Align the hole of the gas strut to the round head of the bolt.
- Press on the gas spring to the bolt shown.

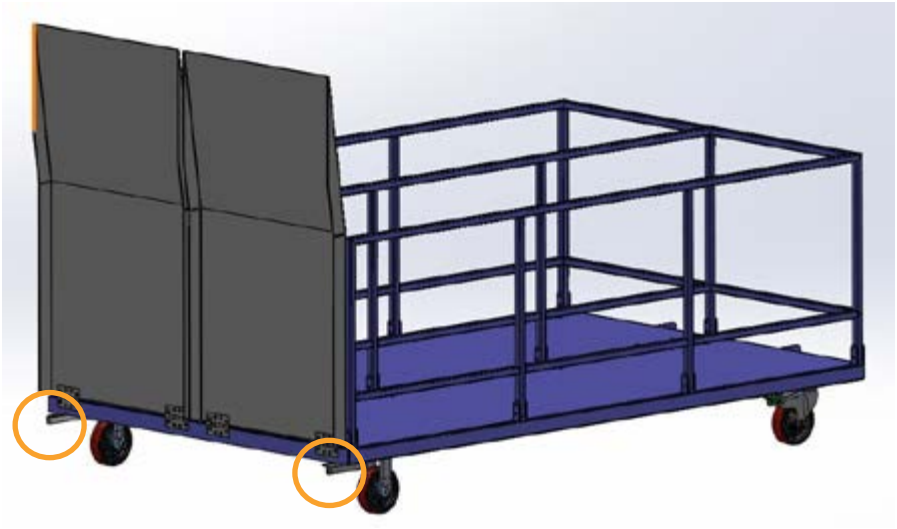

Press in the gas struts on to the frame bolts.

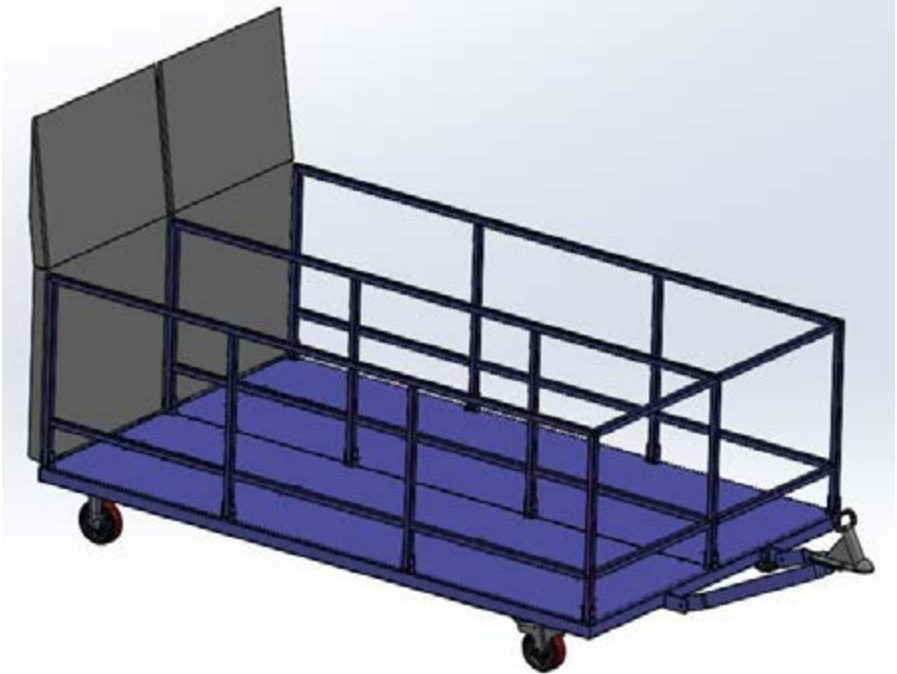

Step 13—completion

Please note:

Once you have finished fitting all the parts, make sure to tighten all of the bolts.

Mobility solutions to help you push, pull & lift with ease.

www.electrodrive.com.au