



TREKINETIC USER MANUAL

11TH EDITION



K2 MK II

Contents

1. Introduction.....	3
Welcome to the team.....	3
Warranty Registration	3
Share Your Experience.....	3
2. Safety Notice	4
3. Unpacking Your K2.....	5
Unpacking.....	5
Assembly	6
4. Getting To Know Your K2.....	11
Quick Start Guide.....	11
Folding the chair for travel (Wheels On).....	16
Folding the chair for travel (Wheels Off)	19
5. Helpful Tips.....	21
Kerbs.....	21
Side plates.....	21
Seat Liner & Pressure Cushions	22
Rear Wheel Punctures.....	22
Front Wheel Punctures.....	23
Air Travel.....	23
6. Maintenance.....	24
General	24
Footrest	24
Rear Castor.....	25
Servicing.....	25
Beach Use.....	25
Nameplate	25
7. Troubleshooting.....	26

1. Introduction

Welcome to the team

Thank you for choosing Trekinetic for your new wheelchair and welcome to the revolution! You are now part of a select group of individuals that have joined us in turning the wheelchair industry on its head and choosing a life of adventure, excitement and independence.

We are delighted that you chose the revolutionary Trekinetic K2 All Terrain Wheelchair and are confident that you will love your new product. The K2 has been designed to be different, but the unique configuration will soon become second nature and open up access to places you simply couldn't access with a traditional wheelchair. This user manual offers important advice and ideas so that you can get the most out of your new wheelchair, so please read it carefully before use. Please contact your local dealer if you have any questions relating to the use, maintenance or safety of the wheelchair.

Where you do not have a local dealer, please contact us by phone or email as below. If you could have your chassis number (which you can find under the seat) to hand when contacting us, that will help us identify your specific wheelchair.

E-mail: info@trekinetic.com

Telephone: +44 (0)1442 252700

Warranty Registration

Your new wheelchair is covered by a 1-year manufacturers return to base warranty. To validate your warranty please head to the below link to register your details:

<https://trekinetic.com/warranty-registration/>

If you have any issue registering your details online, please call us or email using the above contact information.

Share Your Experience

We'd love to see and hear how you're getting on with your Trekinetic wheelchair and so would the rest of the Trekinetic community! Seeing photos of our customers all over the world makes what we do all the more worthwhile, but it also raises awareness of our products and allows others to see the chairs being used.

The easiest way to share your stories is to tag us on social media (Facebook, Instagram or Twitter) using our handle **@trekinetic** and hashtag **#teamtреkinetic**

If you don't use social media, please feel free to email your pictures and video to us using the above email address and we'll share them for you (with your permission of course)

2. Safety Notice

This wheelchair has been designed to the highest standards with a specific focus on user safety.

The revolutionary Trekinetic K2 has been independently tested to ensure it meets or exceeds current strength and fatigue standards but nevertheless, users may put themselves at risk by improperly using their wheelchair or exceeding recommended guidelines.

Many actions are different compared to a traditional four-wheel, rear driven chair so please allow yourself time to explore these in a safe environment, ideally with a companion. Get to know how it performs and test the seat in various positions, for example you will find that the chair is more stable downhill with the seat reclined.

Unlike a conventional four wheelchair, our unique three-wheel design all but ensures you will always have a wheel in contact with the ground, which makes it especially stable off road. You may find that you can go across certain terrains at higher speeds than many other chairs, however, even the Trekinetic K2 has its limits, so always be mindful, that as speed rises, stability and safety decreases.

Always ensure that the footrest is **fully extended** and that the front wheels and rear shock absorber are fully locked in position.

One of the most unstable situations for any vehicle is turning sharply on hills, uneven terrain, high speed or at worse any combination of these. So please remember the general rule*: Going **uphill - backrest up**. Going **downhill - backrest down** (fully reclined).

*This is a general rule and cannot take account of all occupant weight distributions. Users need to determine the position they feel is the most suitable. If in any doubt, please contact the factory or your dealer for further advice. Please also beware of potholes. They can cause instability, just as well as bumps!

Just like a racing driver, for the most efficient progress, control your K2 with utmost sensitivity and precision. Take time to learn these skills and you will be rewarded with improved ability in many conditions, over many different terrains.

When getting in and out of the chair, always make sure the brakes are locked as this will lock the wheels in position to keep the chair still.

Please note that the Trekinetic K2 has been crash tested and therefore is suitable for user in chair transport in a motor vehicle with the appropriate tie down system. This must be specified at point of order or retrofitted by the factory. The K2 vehicle transport system uses special brackets and holes cut into the seat that cannot be done by a 3rd party.

Always use ramps if available and do not descend or turn at high speed. Become acquainted with the kerb climbing techniques and do not strike them at speed. Make a point of being aware of the rear castor's orientation.

The rear shock absorber contains high pressure Nitrogen gas. Under no circumstances apply heat, force or try to dismantle this unit. In the event of malfunction or end of life, contact your dealer or the factory for advice.

Before use, please read all sections of this manual and have the wheelchair serviced every six months.

The maximum user weight is 114 kg and only one person may be carried. Although the K2 is shower proof, it should not be exposed to constant rain for a prolonged period of time and in this case, shelter should be sought as soon as possible. Under no circumstances should the chair or any part of it be immersed in water. Excess exposure to water may cause damage to the mechanics of the chair and damage caused by extensive water ingress will not be covered warranty.

The Trekinetic K2 is classified as Class II vehicle and is therefore not to be used on the road.

3. Unpacking Your K2

If your new K2 has been shipped to you in a container, please read on to understand how to unpack your K2.

If your K2 chair has been delivered fully assembled by a local dealer please skip to [Getting To Know Your K2](#).

Your K2 has been securely packaged to avoid damage during transit and will likely need two strong people to lift once delivered.

Trekinetic deliveries are fully insured but your first job is to check that the container looks to be in good condition (as below), ideally whilst the delivery driver is still present. If there is any damage, like holes or big dents in the side of the carton you must take pictures and insist the driver note it on any delivery note you sign. Ask the driver to take a picture and email it you there and then. It's also a good idea to note the drivers licence number. This way, in the rare event of damage in transit, we will be able to claim in full against our insurers for any repairs or part replacement.



Unpacking

All Trekinetic wheelchairs ship directly from our facility in the UK. Whilst all containers are shipped securely, there can be some subtle differences depending on shipping location and wheelchair configuration.

1. Place the box on the floor with the wooden pallet at the base as per the picture above.
2. Carefully cut the 4 metal straps and remove the lid.
3. Set aside the protection plates on top and remove the upper packaging material
4. Slide the central cardboard sleeve upwards, trying not to tear it as it can be reused if you ever need to ship the entire chair back to us.
5. If the chair has been delivered outside the UK and you can see the wooden frame inside, use a screwdriver (not supplied) to undo the screws in each of the four legs at the base. If not, skip to step 7.
6. Lift up and set aside the wooden structure with the wheel attached.
7. Cut the white cable ties to free the wheels and remove them along with the rest of the packaging
8. Cut the three white cable ties attaching the main body to the base.
9. Set the main body of the K2 on the floor and move the packaging out of the way.

Assembly

1. Typically, all the wheels will be removed during transit and look like the below picture, but in certain situations the wheels may be left on. If that is the case, please just skip the relevant wheel assembly section(s). Please note the below picture shows extended handlebars and cable operated assistant brakes that may not have been selected as an option on your model.



2. To assemble the rear castor, ensure that the armrests are folded back (if present) and carefully turn the chair over so it's upside down. You may also want to fold down the handlebars depending on the configuration. It's best to do this on a soft surface to avoid scratching the seat.

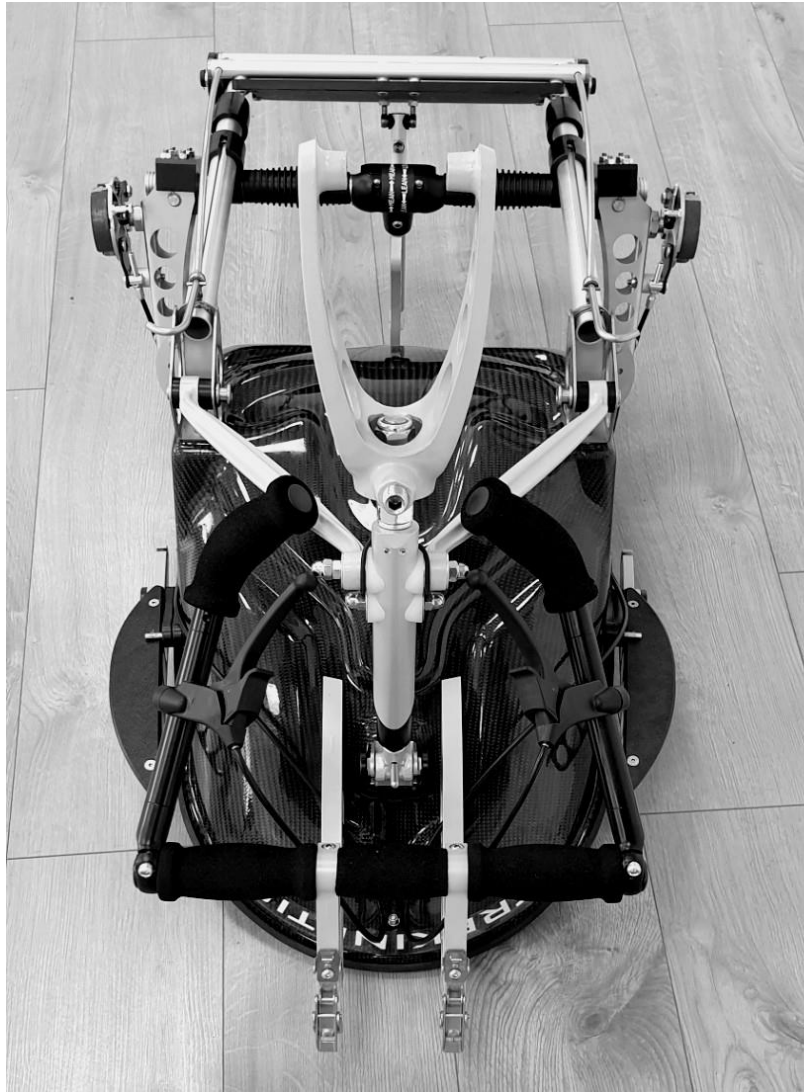

3. To assemble the rear castor, you will need an 8mm A/F Allen Key. If you have a Safari kit, choose the largest of the three Allen keys in the bag. If you don't have the Safari kit option, there will be a key taped to the base of the container.
4. Looking at the chair as in the above picture slide the Allen key through the threaded hole on the left-hand side. Please note that rear castor assembly can rotate, so do ensure that it is in the below position with the large adjustment screw (circled in red below) facing towards you. Then slide one of the silver washers over the end of the Allen key.

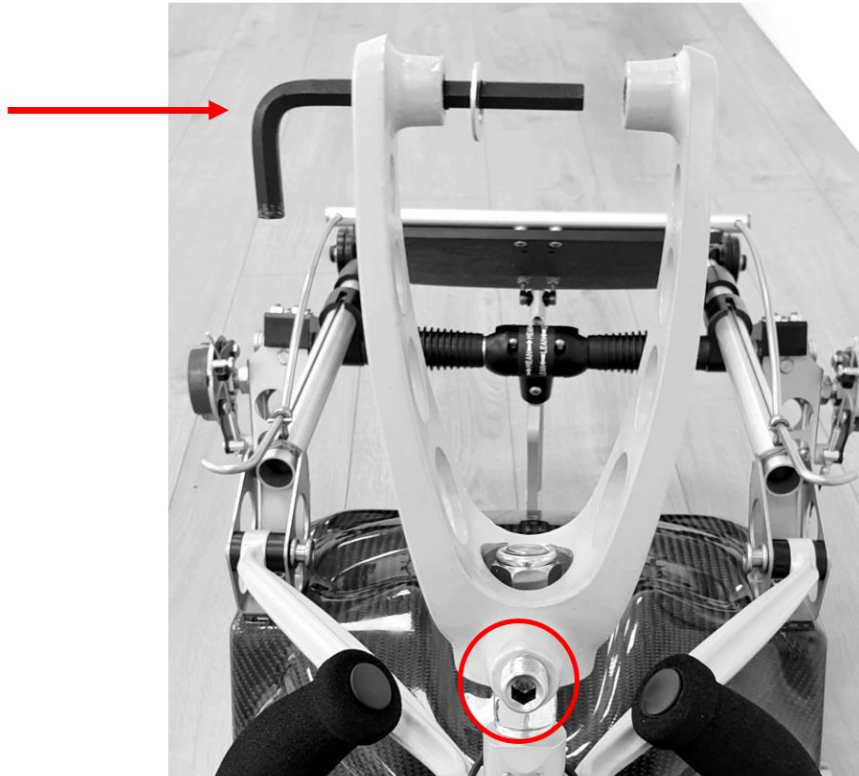

5. Next, locate the rear wheel castor and slide it over the Allen key followed by the second washer on the other side of the wheel. You should now have a metal washer either side of the wheel and inside of the castor fork. This is a bit fiddly, but it will fit, and you only need to do this when replacing the rear wheel.
6. Now this is in place, take the large silver bolt and push it through the rear castor from the other (right hand) side, sliding out the Allen key as it goes through. You may need to jiggle the rear castor about a bit to ensure it's gone through.



Once you can't push it through any further, fully remove the Allen key and use it to tighten the bolt on the other side.

7. Turn the chair back over.

8. Fully extend the footplate (making sure to unhook the elastic over the footplate lever first if you have the upgraded footplate). This will take two hands and may need support from another person. You can balance the seat by holding the front of the seat.



9. You can then fold down the armrests and extend and lock the folding handlebars (if applicable) as below.

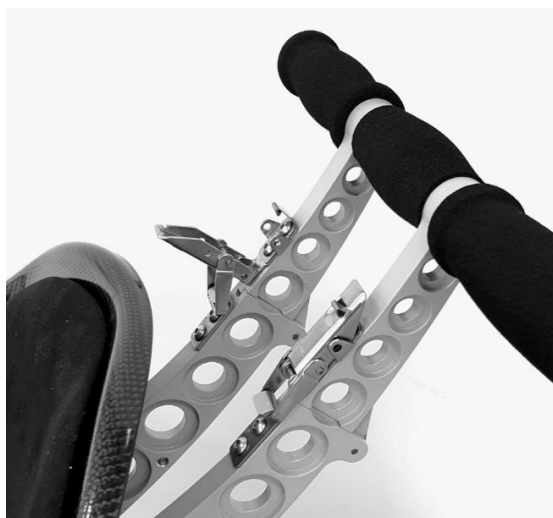

To lock the folding handlebars, first locate the two halves of the handlebar which fit together, then hook the clasp over the catch and pull the clasp back to lock it. This may be a bit stiff but has been designed to be extremely strong to avoid damage. In the above image you can see the nearside clasp locked into position and the far clasp hooked over the catch and ready to be pulled back into the locked position.

10. Next, activate the shock absorber by pressing the silver switch upwards. The chair should automatically rise back into position.

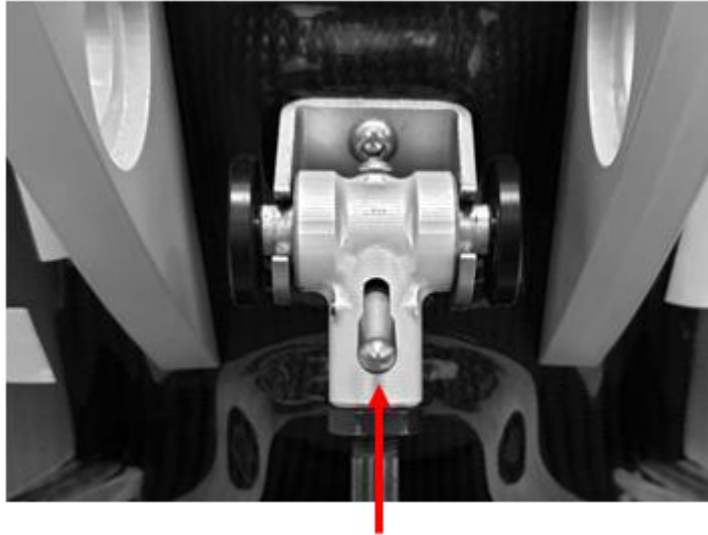

11. It doesn't matter which order you put the wheels on as there is no specific right hand or left-hand wheel to worry about. Ensure the brakes are fully disengaged by pulling up and releasing the dynamic brake lever (optional) or checking that the standard or assistant brakes are fully loose. Press the quick release button in the centre of the outside of the wheel (below) and insert the centre pin into the centre of the hub brake. Once secure, release the centre pin and the wheel should be locked in position.

Quick Release Button

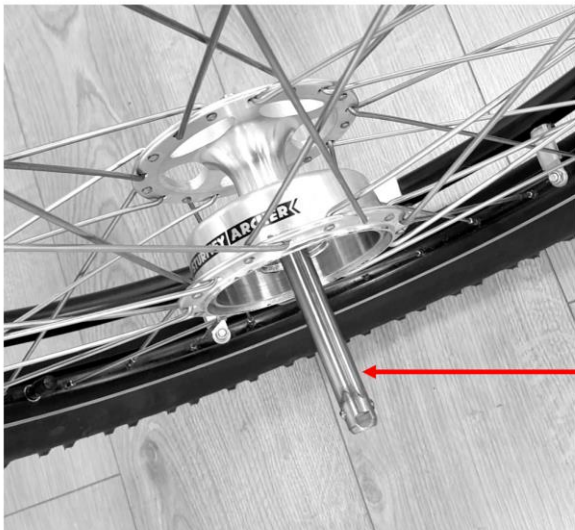

Centre Pin

Hub Brake

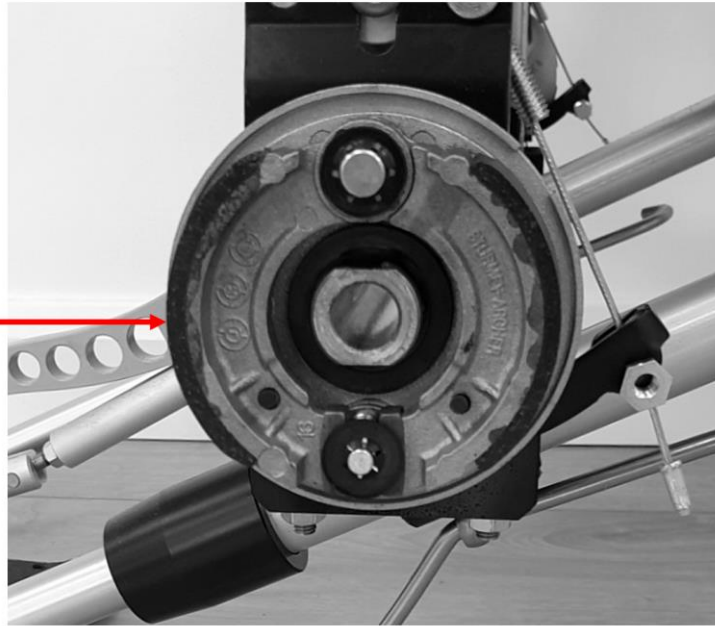

12. Once the wheels are on, you're ready to go!

4. Getting To Know Your K2

Quick Start Guide

Assuming your chair has arrived fully assembled the first step is to ensure it's ready before getting in!

1. Brakes

Depending on which option you've chosen you have a few braking options.

Dynamic Lever Brakes

These are popular with our more active users and provide the ability to steer as well as slow down each wheel independently. Each wheel can be slowed down by gently pulling the levers upwards, but you can also use them as a parking brake for transfers, etc. by pushing them down when stationary. You should feel them lock into place and hold the wheels in a fixed position



Standard Brakes (User or Assistant)

The K2 comes with cable operated ratchet brakes as standard. These can be mounted beside the front wheels for user operation, on the handlebars or on handlebar extensions for assistant operation (as below).



These brakes operate exactly the same way as standard bike brakes. Pulling the brake levers towards you, engages the brakes and releasing the brake levers release the brakes. Each wheel is operated independently and we recommend the smooth application of both brakes simultaneously for controlled stopping. Each brake has a ratchet lock which can be used to lock the wheels in position. We highly recommend engaging the lock when transferring in/out of the chair. To engage the lock, pull the brake levers back then push the locking brackets forward to engage one of the grooves. To release, simply pull back on the main brake levers and then release to disengage the brake.

2. Armrests

The K2 comes with optional folding armrests which can be used as support for getting in or out of the chair. We recommend starting with them down, but you can simply fold them back if you feel they're getting in the way.



3. Seat Angle

Our patented, rear shock absorber helps ensure a smooth ride at all time, while also acting as a tilt in space mechanism to alter the angle of the seat and change the weight distribution in the chair.

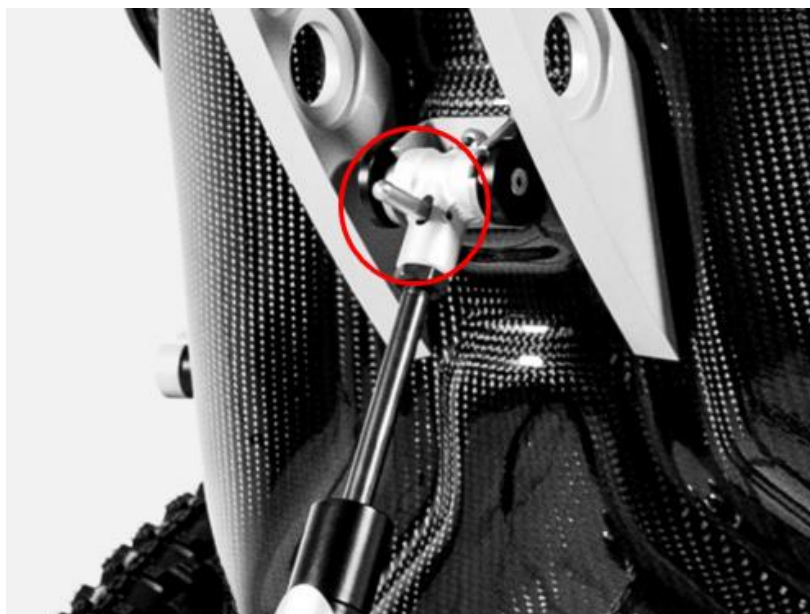

The shock absorber will engage automatically to cushion you from any lumps and bumps that the rear wheel encounters, but it can also be manually engaged to change the angle of the seat and consequently the height of the footplate.

To manually engage the shock absorber and engage the tilt in space mechanism simply press upwards on the metal 'switch' that protrudes outwards. If nobody is sitting in the chair, activating the shock absorber will cause the chair to right itself and arrive at the most upright position. Similarly activating the shock absorber whilst pushing down on the top of the seat will cause the seat to recline. This can be done whilst in the chair by either leaning backwards or tipping forwards to change the seating position. Some users may need support in doing

this but the rear wishbone can be used to 'pull' down off if you're unable to recline the seat by simply leaning backwards. Some users prefer to use the leave the chair in a half-way position which also works pretty well in most scenarios.

We could recommend having the chair in a reclined position when going downhill and an upright position when going uphill to improve weight distribution. You will also find that having the chair reclined provides increased ground clearance when going over rougher terrain.

4. Varicam System

Our patented Varicam system allows you to change the angle of the wheels by simply turning a bar under the seat. Set the bar to 'MEAN' for extra stable, off road use and 'LEAN' for indoor use. 0-8 degrees in 10 seconds. Zero tools required.

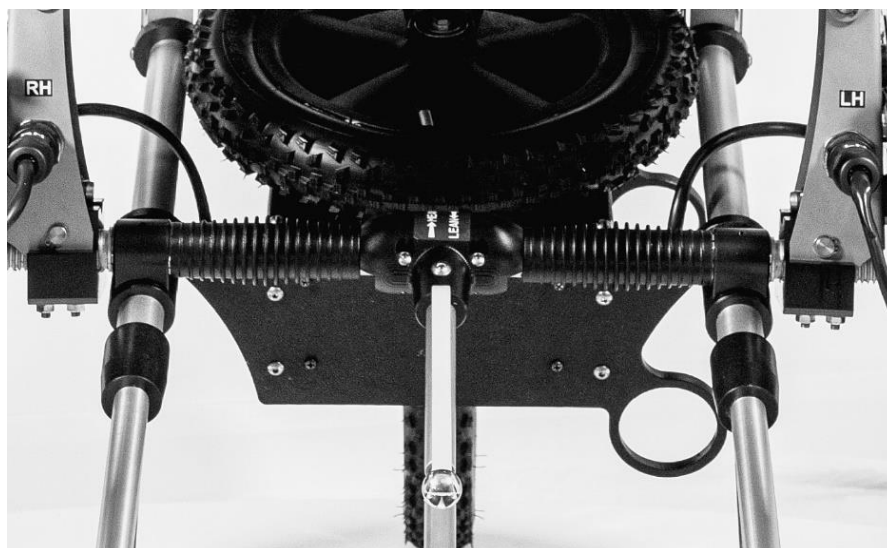

The Trekinetic K2 has been designed to be as stable as possible off road but as practical as possible when used indoors and around town. For normal day to day use, the chair can be left in the 'LEAN' position which means the wheels are vertical and you should be able to fit through all but the narrowest of doorways. If you are venturing off-road though we recommend switching to 'MEAN' mode which changes the angle of the wheels by 8 degrees and makes the chair even more stable over rougher terrain.

To change the camber simply turn the camber bar clockwise for LEAN or anti-clockwise for MEAN, following the arrows on the centre of the bar. If this gets stuck, you can often loosen the mechanism by gently rocking the wheels from side to side.



Please note that the adjustment of the camber **cannot be done** with the user in the chair and camber must be fully set in the MEAN or LEAN positions. This means tightening the bar at either setting.

We recommend selecting the MEAN position wherever possible as this offers the maximum stability. Do not alter the setting up screws in the black plastic blocks at either end of the camber bar. These are for setting at service intervals only.

5. Footplate

Next up, you want to get the footplate out of the way. The below example shows the upgraded locking and retracting footplate, but the same motion applies to the standard footplate. To raise the footplate, either pull the lever upwards (for the locking and retracting footplate) or push the footplate in by hand (or foot) if you have the standard footplate. If you have the lever operated option, there is an elastic loop just under the seat to hold the lever in place should you need it. This is more commonly used when transporting the K2, but it will stop the footplate sliding back down.



You are now ready to get into your K2! Transferring into the K2 is simpler than it may look, just ensure that if you're transferring from another chair that you get as close as possible to the seat, by positioning yourself at an angle of about 45 degrees. Certain users may need support with this process.

Once you're in, slide the footplate back down, ensure it's fully extended/locked and you're ready to go!

6. Time for a test drive

Your K2 is now ready to go. Please take it easy for the first few days whilst you get accustomed to how the chair performs in different scenarios. Even if you're a seasoned wheelchair user, your Trekinetic K2 has a lot of differences to conventional wheelchairs and may take some getting used to! That said, we are confident that you will master the basics very quickly and will enjoy your new K2 almost immediately.

Folding the chair for travel (Wheels On)

You Trekinetic K2 can be folded down with and without the wheels on. Firstly, we'll go through how to fold it down with the front wheels still on.

1. For maximum space efficiency, set the camber to the LEAN position by turning the camber bar clockwise. The wheels should now be in a vertical position.



2. Retract footplate and hook elastic loop under seat around footplate handle (if using upgraded footplate).



3. Recline the seat by activating the shock absorber and pressing back/down until the shock absorber is fully compressed.



4. Unclasp the locks and fold down the handlebars (if applicable)



5. Fold armrests backward (if applicable)



6. Disassemble rear castor assembly. To release the rear strut, squeeze the two plastic buttons either side of the head of the shock absorber and pull the head towards you and out of the clasp.

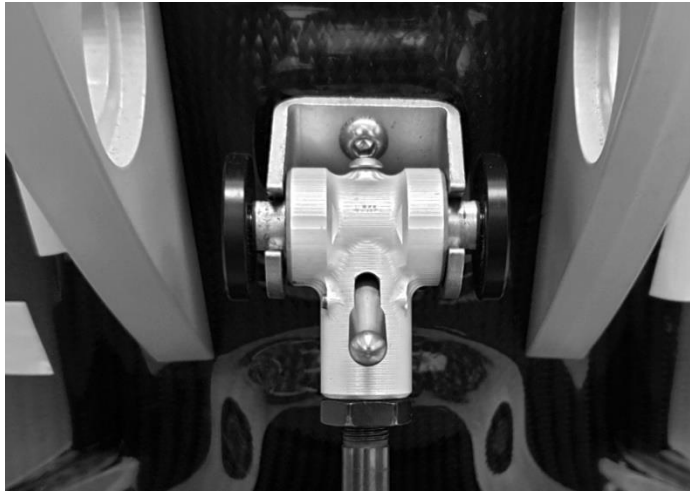

(When replacing this structure, simply reverse the initial movement, squeezing the two plastic buttons on either site and inserting it back into the metal clasp. Occasionally it can twist slightly, so ensure it is straight and fully engaged into the clasp. You should hear a satisfying click when inserted correctly.)

Once this is separated, fold down the strut behind the seat, resting the top of the shock absorber against the top of the seat. There is another piece of elastic at the base of the rear strut which will hook over the clasp on the back of the seat. This will stop the rear wheel assembly from dropping down whilst the wheelchair is transported (see picture below).



7. Your K2 can now be lifted into a vehicle or you can attach our hoist kit if using a mechanical hoist system.

Folding the chair for travel (Wheels Off)

You Trekinetic K2 can be folded down with and without the wheels on. The below sequence is how to fold it down with the front wheels removed.

1. To remove the front wheels, simply depress the quick release button in the centre of each wheel and pull the wheel towards you. It helps if the wheelchair is tilted slightly so the wheel that's being removed is off the ground. To re-attach, simply reverse this action, depressing the quick release button and sliding the pin into the central hole on the wheel hub before releasing.



2. Fold armrests backwards (if applicable)



3. Unclasp locks on folding handlebars (not applicable to standard non-folding handlebars) and fold handlebars downwards



4. Manually activate the shock absorber by pressing the valve leave upwards and recline the seat so that the shock absorber is fully compressed



5. Disassemble rear wheel assembly. To release the rear strut, squeeze the two plastic buttons either side of the head of the shock absorber and pull the head towards you and out of the clasp.



(When replacing this structure, simply reverse the initial movement, squeezing the two plastic buttons on either site and inserting it back into the metal clasp. Occasionally it can twist slightly, so ensure it is straight and fully engaged into the clasp. You should hear a satisfying click when inserted correctly.)

Once this is separated, fold down the strut behind the seat. There is another piece of elastic at the base of the rear strut which will hook over the clasp on the back of the seat. This will stop the rear wheel assembly from dropping down whilst the wheelchair is transported.



6. Holding the chair stable (by grabbing the front lip of the seat) push the footplate back up, securing where possible (locking & retracting footplate only). Your K2 should now look as below and is ready to transport!

5. Helpful Tips

Kerbs

Always seek out a ramped kerb if at all possible – it's simply smoother, safer and easier on your K2 and you.

If this is not possible, there are two ways in which to get up a kerb, namely forwards or backwards. The size of kerb one can easily negotiate depends on many factors.

When the chair is fully reclined, the footrest is at its highest and small kerbs can be taken in a forward's direction. Larger kerbs represent bit more of a challenge but with some practise, they can be taken by reversing.

Leaning forwards (if possible) allows the chair to tip forward onto the front anti tip rollers and at the same time, raises the rear castor off the ground. It is then possible to reverse the chair onto the kerb, but you will need some good upper body strength to do this.

Always ensure that the castor is aligned in the forwards position when negotiating kerbs. Kerbs need to be negotiated in one movement, not by rolling backwards and forwards. To move off a kerb (up to 50mm) lean back, with the shock absorber retracted and proceed **slowly forwards** off the kerb.

Side plates

When you are seated in the chair fit the side plates by pushing the two pins into the two sockets on either side of the chair, textured side facing outside the chair. The pins have deliberately been designed to bend if excess pressure is applied, to prevent damage to the seat itself. Be sure to remove them before you get out of the chair though as accidentally sit on the edge could still damage the carbon fibre seating system which would not be covered by warranty. Please note that the side plates are designed to stop your clothes getting dirty or trapped – not to hold your legs in position. If you need to hold your legs, use either a strap and/or extra padding.

Seat Liner & Pressure Cushions

The suede seat lining is attached by Velcro for easy removal. Clean only with a damp cloth and do not immerse in water. Whilst the K2 can be used without any additional cushioning the liner is not designed to prevent pressure sores. If you are concerned about pressure sores, please show the wheelchair to your Occupational Therapist before use. If you already possess a suitable pressure relieving cushion that is soft on both upper and lower surfaces, this can be used in the interim. Trekinetic also offer several different cushions so please speak to your local dealer or contact us directly if you feel you need further support in your K2.

Rear Wheel Punctures

If you encounter a puncture in the rear castor, the most effective solution is to change the wheel entirely and not attempt a repair in the field. If you have purchased a spare rear wheel, it will be attached to the underside of the seat. The optional Safari kit contains all the required equipment for dealing with either rear or front wheel punctures, including the relevant 10mm spanner or Allen key to remove the rear wheel.

For the rear wheel, use the hexagonal key set and undo the bolt holding the rear wheel on. Note the positions of the two washers, between the wheel bearings and the castor fork. For a reminder see sections 2-7 of [Assembly](#) which describes this process in more detail. Fit the new wheel, checking it spins freely. Inflate the tyre to 45-50 psi (or firm to touch) with the mini pump, also in the Safari kit (pic below).



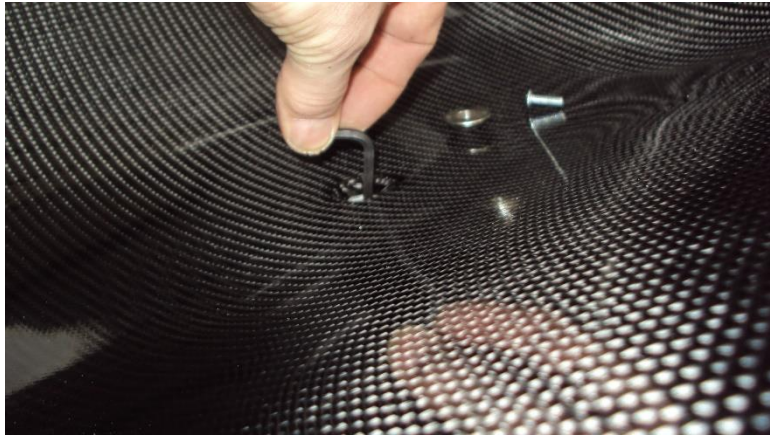

On some 19" models (only) you will need to remove the sealing plug and access the spare wheel retaining screw from above.

Front Wheel Punctures

Before leaving home, acquaint yourself with how to change an inner tube. The Safari kit (if purchased) contains 3 tyre levers and a new inner tube for one front wheel. Ensure all air is out of the punctured inner tube and use the plastic tyre levers to move the tyre bead over the wheel rim, to enable you to remove the inner tube. Before re-assembly, try and locate what caused the puncture and remove it. Carefully install the new inner tube and refit the tyre bead.

Make sure you do not get the inner tube twisted or pinched between the tyre and the rim. Inflate it to 50 psi or feel it and match to the other side. In extremely hot conditions, you may experience the tyres 'popping' off the rims. In this case the heat is probably causing an increase in tyre pressure. Bleed out a little air (depress valve for one to two seconds) refit and see if things improve. For long distance expeditions, contact Trekinetic as we can advise further.

Air Travel

Trekinetic recommend that you do not allow, the wheels to be removed or the chair to be folded, prior to being carried in airline holds. Ensure that the airline operator's staff understand how the brakes are applied and always advise the airline in advance that a wheelchair will need to be carried. You may cover the seat with bubble wrap or similar for extra protection, if desired.

If you are asked by the airline, the maximum assembled size is 1140mm Long x 860mm Wide x 950mm High. The weight is circa 15.5kg.

Our users have proven, that the method above, is the one mostly likely to ensure that your Trekinetic arrives at your destination, safely and undamaged.

Technical Data

Maximum dimensions

Maximum Width: approx. 860mm (19" Version)

Maximum Length: approx. 1140mm

Maximum Height: approx. 840/950mm (with/without handlebars)

Dimensions folded.

Body with wheels removed: approx. 920 x 450 X 560 mm

Wheels: approx. 640 diameter X 100mm thick each

Basic chair with wheels complete: approx. 14.5 kg (excludes any extras or XL model)

Body with wheels removed: approx. 8.5kg

Wheels: approx. 3.0 kg each

6. Maintenance

Your Trekinetic K2 needs to be regularly maintained to stay in good working order. Below is a short guide with some tips on how to maintain your K2.

General

Trekinetic recommend that you check the tyre pressures at weekly intervals.

Check all nuts and bolts for tightness every 4 weeks and use only metric hexagonal keys in good condition. Ensure that keys are inserted fully and do not over tighten (see torque settings below). Any locking nylon insert nuts must be replaced with new, if removed. If you are not sure, please contact your dealer or contact us directly if you don't have a local dealer.

Use only mild household cleansers and do not use spirit or solvents that could attack the Carbon Fibre. Use only a damp cloth for cleaning the upholstery and remove it for drying. The same applies to the chair, should it get wet.

Perform these operations on a non-slip surface and apply the brakes

Torque settings

M4 screws 2.6 Nm

M5 screws 5.1 Nm

M6 screws 8.3Nm

Lubrication

Wheel Axles

A small amount of sewing machine or 3 in One oil should be applied to the quick release wheel axles every 6 weeks. Take care not to get oil inside the brake hubs or on the brake linings.

Footrest

In the event of tightness of the sliding footrest or cross shaft threads an amount of **Nylon** or **WD40** type **lubricant** may be applied to the threads and into the slots in the tubes immediately under the monocoque seat.

Rear Castor

The rear wheel castor fork has an M16 grub screw that is used to vary the detent pressure on the rear wheel, which varies how much effort is required to turn the rear castor. This typically doesn't need adjustment, but it may warrant tightening or loosening slightly if the user is particularly heavy or light respectively.



To re-grease, undo the grub screw completely, fill the cavity with general purpose automotive grease and refit the screw, whilst periodically rotating the castor. Repeat until grease is seen appearing from the top bearing. Wipe clean. Re-greasing is only normally required at service as stated below.

Servicing

We recommend an initial service after the first 6 months of use as this is when the chair really beds in and adjusts to its new user. All of our chairs leave the factory with a generic mechanical setup but as each chair is used by a different person, often in different ways, the chair often reacts differently and we can adjust and tune this as the first service interval.

Following the initial service, we recommend a follow up service every 6-12 months after that depending on use. Trekinetic users are welcome to book services in directly with the factory or contact their local dealer who may be able to offer a local service.

Beach Use

Sand and sea water air can easily damage the moving parts of your wheelchair. Clean the wheelchair thoroughly after exposure, if you ever use your chair on sand or in abrasive environments.

Do not try and dismantle the wheelchair yourself, beyond the guidelines in the above sections. The method of assembly is not necessarily obvious, and breakage or failure may occur with incorrect disassembly or reassembly. Many of the screws also have small hexagonal sockets that can be easily rounded off, making it very difficult to remove.

Nameplate

Details of your specific K2 including chassis number, etc. are located on the underside of the seat and behind the rear padding.

The nameplate indicates the exact model designation and other specifications. Please provide the following whenever you have to arrange service, order replacement parts or discuss your wheelchair.

Model - K2

Chassis Number -

GMDN number -

Year of manufacture -

7. Troubleshooting

The Trekinetic K2 is an advanced machine, with tightly integrated mechanical components. It is crucial that it is maintained in line with the guidance in this manual and serviced regularly to ensure good working order. The below list however provides some suggestions to some known issues in all cases, please switch off power before performing checks.

1. Wheelchair feels 'wobbly' or pulling to one side

- Camber bar not fully tightened (rotated) in direction of either 'MEAN' or 'LEAN'.
 - There is no acceptable mid position between the two extremes so it must be fully set at one position.
- Incorrect tyre pressures
 - Re-pressurise to 50 psi all round
- Wheels and quick release axles not pushed fully in.
 - Refit correctly
- Rear strut bracket not full engaged
 - Refit correctly
- Rear castor loose
 - Speak to dealer
- Screws loose
 - Check all nuts and bolts and tighten

2. Wheelchair not running straight

- Tyre pressures uneven
 - Re-pressurise to 45-50 psi all round
- Rear castor nut loose and castor misaligned
 - Tighten nut if possible then seek dealer assistance. A loose castor will eventually become detached, so do not continue without attending to the problem.

3. Wheelchair difficult to turn

- Check rear castor is rotating correctly. It should rotate freely, but a slight increase in pressure at the straight-ahead position, should be felt. Apply general purpose grease through grease point if required or see dealer.
- Adjusting the rear grub screw will change the pressure on the spring and can make it harder/easier to turn.

4. Tyres rubbing or too close to seat

- Camber bar not fully tightened
 - Tighten Camber bar
- Carriers need adjustment
 - See dealer
- In an emergency, rotate the crossbar towards 'LEAN' to tilt the wheels outwards. Seek dealer advice as soon as possible.

5. Footrest difficult to slide

- Lubrication required
 - Apply a spot of nylon lubricant (or WD40) to the telescopic tubes and inside the slots in the tubes immediately under the underside of the seat. Do not use general grease in this area, as it may dissolve the plastic parts.
- Sand, grit or dirt ingress
 - Clean out if possible or see dealer

6. Wheelchair pulling to one side under braking

- Uneven application of brake levers
 - Apply brakes evenly
- Brakes worn unevenly and need adjustment
 - See dealer

7. Brakes ineffective

- The brakes will need adjustment from time to time, due to wear of the linings.
- We recommend that you let your dealer perform these adjustments for you.
- If you hear a 'rumbling' type noise during braking - it is possible that the brakes require immediate replacement. See your dealer without delay

8. Chair is not rolling very far or tough to propel uphill

- Re-pressurise to 45-50 psi all round
- Push harder!