

N SERIES

1.5T - 3.5T

4-WHEEL ELECTRIC FORKLIFT

UN forklifts are designed to excel in the most challenging environments with increased safety, enhanced cooling systems, reduced noise and vibration all with low maintenance. With refined performance at an affordable price, UN Forklifts reduce the total cost of ownership and provide reliable and efficient solutions to drive productivity in your operations.



MODEL		1.5T	2.0T	2.5T	3.0T	3.5T	4.0T	4.5T	5.0T
GENERAL SPECIFICATIONS									
Load Capacity	T	1.5T	2.0T	2.5T	3.0T	3.5T	4.0T	4.5T	5.0T
Load Capacity	Q(kg)	1500	2000	2500	3000	3500	4000	4500	5000
Load Centre	mm	500	500	500	500	500	500	500	500
CHARACTERISTICS & DIMENSION									
Rated Lift Height	H3(mm)	3000	3000	3000	3000	3000	3000	3000	3000
Free Lift Height	H2(mm)	100	100	100	100	100	84	84	84
Fork Size (LxWxT)	mm	920x120x35	1070x120x40	1070x120x40	1070x125x45	1070x125x45	1070x150x50	1070x150x50	1070x150x50
Mast Tilt Angle (F/R, α/β°)	deg	6°/12°	6°/12°	6°/12°	6°/12°	6°/12°	6°/9°	6°/9°	6°/9°
Length to Face of Fork	L1(mm)	2150	2380	2380	2475	2535	2940	2940	2940
Overall Width	B1(mm)	1090	1150	1150	1225	1225	1612	1612	1612
Mast Lowered Height	H1(mm)	2025	2055	2055	2070	2070	2250	2250	2250
Mast Extended Height (With Backrest)	H4(mm)	4055	4070	4070	4070	4070	4260	4260	4260
Overhead Guard Height	H5(mm)	2125	2125	2125	2125	2125	2300	2300	2300
Turning Radius	Wa(mm)	1995	2080	2080	2215	2280	2705	2705	2705
Fork Overhang (Wheel Center to Fork Face)	X(mm)	409	478	478	485	485	550	550	550
Front Tread	B2(mm)	890	970	970	1000	1000	1300	1300	1300
Rear Tread	B3(mm)	920	950	950	980	980	1200	1200	1200
Ground Clearance	H7(mm)	110	120	120	130	130	125	125	125

ISUZU



Market leading engines ensure superior performance, durability and excellent fuel efficiency. All diesel forklifts have Mitsubishi or Isuzu engines. The LPG and gasoline forklifts utilise Nissan engines.

MODEL		1.5T	2.0T	2.5T	3.0T	3.5T	4.0T	4.5T	5.0T
Wheelbase	Y(mm)	1380	1500	1500	1600	1600	2000	2000	2000
Fork Spread (Min/Max)	mm	140/970	250/1040	250/1040	250/1100	250/1100	250/1380	250/1380	250/1380
Working Aisle Width With Pallet (1200 Lengthways)	Ast(mm)	3605	3830	3830	3970	4035	4655	4655	4655
Working Aisle Width With Pallet (800 Lengthways)	Ast(mm)	3805	3960	3960	4100	4165			
TYRE									
Tyre (Front x 2)	mm	6.50-10-10PR	7.00-12-12PR	7.00-12-12PR	28x9-15-12PR	28x9-15-12PR	28x12.5-15	28x12.5-15	28x12.5-15
Tyre (Rear x 2)	mm	5.00-8-10PR	18x7-8-14PR	18x7-8-14PR	18x7-8-14PR	18x7-8-14PR	21x8-9	21x8-9	21x8-9
PERFORMANCE									
Travel Speed (Full Load)	km/h	12	12	12	12	12	12.5	12.5	12.5
Travel Speed (No Load)	km/h	13	13	13	13	13	13.5	13.5	13.5
Lifting Speed (Full Load)	mm/sec	280	300	300	280	280	290	290	290
Lifting Speed (No Load)	mm/s	380	420	420	440	440	400	400	380
Max.Gradeability (Full Load)	%	16	18	18	16	12	12	12	12
Max.Gradeability (No Load)	%	18	20	20	18	13	13	13	13
WEIGHT									
Total Weight (Include Battery Box)	kg	3060	4160	4420	5160	5420	7020	7020	7280
POWER & TRANSMISSION									
Battery	V/Ah	48/450	48/620	48/620	80/500	80/500	80/840	80/840	80/840
Operating Pressure	Mpa	14.5	17.5	17.5	17.5	17.5	20	20	20
Diver Motor	kw	7.5	11	11	12	12	11x2	11x2	11x2
Pump Motor	kw	10	12	12	13-5	13-5	25.4	25.4	25.4
Controller Type		AC	AC	AC	AC	AC	AC	AC	AC
Controller Manufacturer		ZAPI	ZAPI	ZAPI	ZAPI	ZAPI	ZAPI	ZAPI	ZAPI
EXTRAS INCLUDED									
Side-Shift		•	•	•	•	•	•	•	•
Fork positioner		•	•	•	•	•	•	•	•
Solid Non-Marking Tyres		•	•	•	•	•	•	•	•

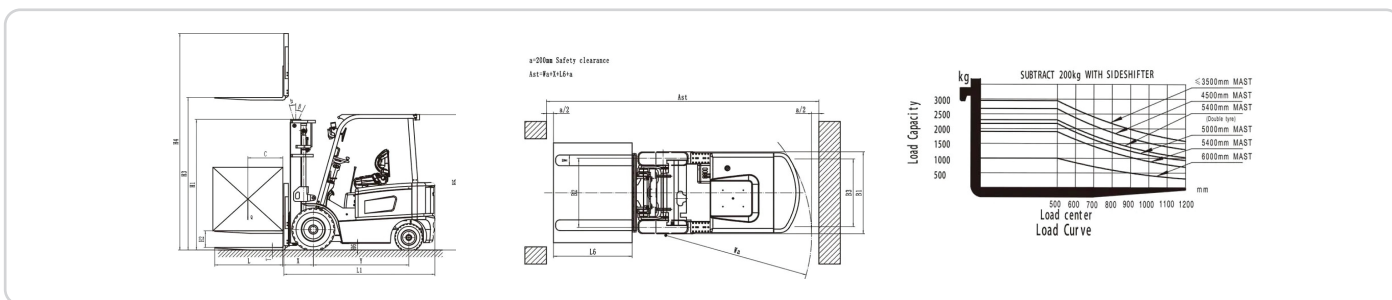

Market leading engines ensure superior performance, durability and excellent fuel efficiency. All diesel forklifts have Mitsubishi or Isuzu engines. The LPG and gasoline forklifts utilise Nissan engines.