

# STARPOINT VRM

Eye nut

Full WLL in any direction  
with 4:1 design factor

100% electro-magnetic  
crack detection tested

Manufactured using high  
tensile CrNiMo - steel



## Product features / STARPOINT VRM Eye nut

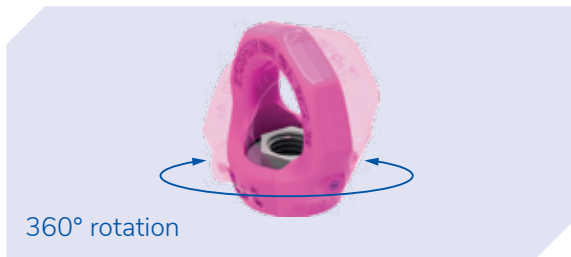

- ✓ Full WLL in any direction with 4:1 design factor
- ✓ 100% electro-magnetic crack detection tested
- ✓ Manufactured using high tensile CrNiMo - steel
- ✓ Side loading permissible when adjusted to the correct plane

- ✓ Shape: star shaped (clearly distinguishable from other collared eye nuts)
- ✓ Complies with EN 1677
- ✓ Painted in the unique durable RUD pink powder coat finish

TYPE	WLL [t]		Weight [kg]	A	B	C	D	E	G	H	I	K	L	M	N	Ref. No.
	F1	F2														
VRM-M6	0.5	0.1	0.05	28	9	7	20	23	28	17	13	37	11	M6	9	7900786
VRM-M8	1.0	0.3	0.1	35	11	9	25	25	30	21	16	47	14	M8	12	7992989
VRM-M10	1.0	0.4	0.1	35	11	9	25	25	30	21	16	47	14	M10	12	7990311
VRM-M12	2.0	0.75	0.2	42	13	10	30	30	34	25	20	56	17	M12	14	7990312
VRM-M16	4.0	1.5	0.3	49	15	13	35	36	40	31	22	65	21	M16	19	7990314
VRM-M20	6.0	2.3	0.5	58	17	16	40	41	50	35	29	76	23	M20	24	7990315
VRM-M24	8.0	3.2	0.9	70	20	19	49	51	60	41	35	92	29	M24	30	7990316
VRM-M30	12.0	4.5	1.5	87	26	24	60	66	75	51	44	114	36	M30	36	7993008

Dimensions and specifications subject to change

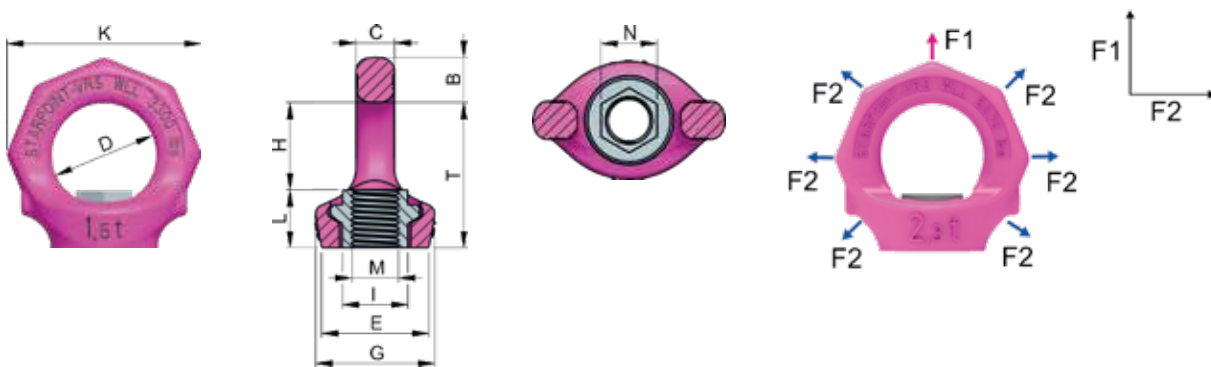

**Head Office**  
 12 Commerce Place, Larapinta QLD 4110  
 T: +61 7 3809 1300 F: +61 7 3809 1301

**WA Office: Perth**  
 107 Broadway, Bassendean WA 6054  
 T: +61 8 6278 1788 F: +61 8 6278 4788

E: sales@rud.com.au  
 W: www.rud.com.au  
 ABN: 74 010 547 949