

MODEL RANGE

FH16 8x4 Rigid Air Suspension FH 84RF 6A

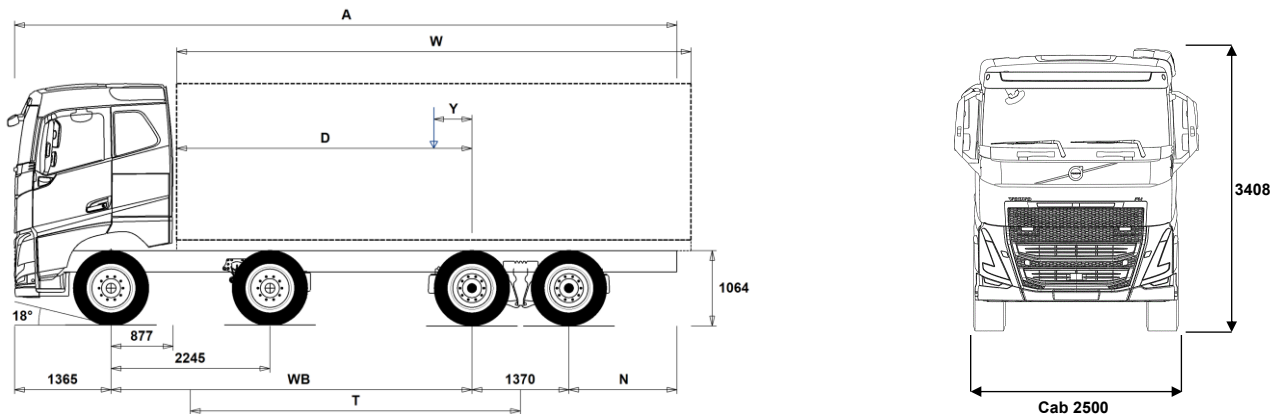

Chassis Dimensions [mm]

WB Wheelbase	5100	5600
A Overall Chassis Length	10660	11410
D Center of rear axle to front of body	4173	4673
N Rear Overhang (Min.)	825	1225
N Rear Overhang (Max.)	2825	3075
T Theoretical Wheelbase	4662	5162
Y Center of Gravity for Payload (Min.)	291	416
Y Center of Gravity for Payload (Max.)	291	416
W Body Length (Min.)	7764	8515
W Body Length (Max.)	7764	8515

Chassis Weights [kg]

Front Axles	7400	7345
Rear Bogie	2895	3005
Kerb Weight	10295	10350
Payload (including body, driver, fuel, etc.)	17205	17150

Turning Diameter [mm]

Turning Circle Diameter Kerb to Kerb	20600	22200
Turning Circle Diameter Wall to Wall	22000	23600

Plated Weights [kg]

	Plated	Design
Gross Vehicle Weight	27500	37000
Gross Combination Weight	40500	44000
Front Axles	11000	16000
Rear Bogie	16500	21000

Important Notes

Chassis Dimensions

Cab Height: +375 mm for CAB-HSLP, -203 mm for CAB-LSLP, +517 mm for CAB-XHSL.

D-measure includes a front clearance of 50 mm and for rigid trucks also a subframe of 100 mm.

Height can vary ± 20 mm for leaf and ± 10 mm for air suspension.

All dimensions are for unladen chassis and any tag axles down. Chassis height used: CHH-HIGH.

Rear overhang used for vehicle weight calculation is the maximum rear overhang (N Max.) for selected wheelbase.

Height change when chassis height CHH-MED,FRAME300: 0 mm.

Weight and dimensions are based upon the following tyres:

Front Axle Tyres: 315/80R22.5
 Drive Axle Tyres: 315/80R22.5

Chassis weight includes oil, water, AdBlue, 0 litres fuel and without driver. Kerb weight can vary ± 3%.

Turning diameters are theoretically calculated.

Legal weights can differ from country to country.

For more detailed weight information, including optional equipment weights, ask your Volvo sales contact to enter your specification into the Volvo Weight Information system (WIS).

Do NOT use this drawing for bodybuilding. Refer to Volvo Bodybuilder Instructions and chassis assembly drawing FH84RF6A.

MODEL RANGE

FH16 8x4 Rigid Air Suspension FH 84RF 6A

Truck use

- RC-ROUGH** Operating class on/off road
- RC-SMOOTH** Well Maintained Surfaced Roads >95% Driving Distance
- TIPP-PRE** Tipper Preparation
- UNIFORM** Basic uniform vehicle

Core components

- CHH-HIGH** Chassis Height High approx. 1025-1050mm (depending on tyre selection)
- CHH-MED** Approximate chassis height 900 mm
- CHH-XHIGH** Chassis Height Extra High approx. 1100-1162mm (depending on tyre selection)
- RADD-G2** Rear Air Suspension - High Clearance
- RADD-RIG** Rear Air Suspension
- FH16HSL6** High Sleeper Cab
- FH16LSL6** Low Sleeper Cab
- FH16SLP6** Sleeper Cab
- FH16XHS6** Globetrotter XL Cab
- EU4SCR** Eu4 SCR (Selective Catalytic Reduction)
- EU5EEV** Eu5 SCR Enhanced Environmentally Friendly Vehicle
- EU5SCR-M** Eu5 SCR Selective Catalytic Reduction (mandatory)
- EU6SCR** Eu6 SCR (Particulate Filter & EGR) Single Stage Turbo
- EU7SCR**
- D16C550** Volvo D16C 16 litre turbo charged diesel
Power: 550 hp (405kW)
Torque: 1843 lb.ft (2500Nm)
- D16C610** Volvo D16C 16 litre turbo charged diesel
Power: 610 hp (449kW)
Torque: 2065 lb.ft (2800Nm)
- D16E540** Volvo D16E 16 litre turbo charged diesel
Power: 540hp (402kw)
Torque: 1917lb.ft (2600nm)
- D16E600**
- D16E700**
- D16G540**
- D17A600** Eu6 17 litre Engine 600hp/3000nm/441kW
- D17A700** Eu6 17 litre Engine 700hp/3400nm/515kW
- EBR-EPG** Exhaust Pressure Governor
- EBR-EPGC** Engine Brake Compression EPG
- EBR-VEB+** Volvo Engine Brake + (VEB+)
- AT2812** Volvo I-shift 12 Speed Automatic Transmission (2800nm)
- ATO3112** Volvo I-shift Automatic Transmission with Overdrive (3150nm)
- ATO3512** Volvo I-shift Automatic Transmission with Overdrive (3550nm)
- ATO3812** Volvo I-shift Automatic Transmission with Overdrive (3800nm)
- ASO-C** Crawler Gears
- ASO-ULC** Ultra Low Crawler Gears
- TAAXLIFT** Tandem axle lift
- RTH2610B** Volvo RTH2610B hub reduction rear axles
4 planet gears per hub
Axle rating: 26,000 kg
115 tonne train weight
(Application approved)
- RTH2610F** Hub Reduction Tandem 26t GCW100t (version F)
- RTS2310A** Single Reduction Tandem 23t GCW100t
- RTS2370A** Rear single reduction tandem axles
Axle rating: 23,000 kg
Cross axle diff lock & power divider

Packages

- 1LIVING** 1 bed resting package
- 1LIVING+** 1 bed resting package plus
- 2LIVING** 2 bed resting package
- 2LIVING+** 2 bed resting package plus
- INFOBASE** Standard Level Information Platform
- INFOHIGH** High Level Information Platform
- SAFEBAS**
- SAFEPLUS**

Standard Equipment Optional Equipment

For more detailed information about cab and powertrain equipment, please refer to separate specification sheets.

For all possible options and combinations of options please consult your Volvo sales contact who can create a specification to match your requirements using the Volvo Sales Support system (VSS).

The factory reserves the right to modify design and change equipment without previous notification. The specification can vary from country to country.

- OFFROADS** Construction package on Sleeper Cab
- CHASPAC** Chassis Package - Rigid

Chassis

- FST-AIR** Air Bag Front Suspension
- FST-PAR** Parabolic leaf spring front suspension
- FST-PAR3** 3 Leaf Parabolic Front Springs (stiffer than normal)
- FST-PL1** 2 Leaf Parabolic Front Springs - Lightweight Composite Support Leaf (normal stiffness)
- FSLB-BAS** Front Suspension Levelling Stroke - Standard
- FAL13.0** Front axle rating: 13,000 kg
- FAL16.0** Front Axle Load 16 tonnes
- FAL18.0** Front Axle Load 18 tonnes
- FAL20.0** Front Axle Load 20 tonnes
- FSTAB** Front stabilizer, normal stiffness
- FSTAB2** Front stabiliser bar increased stiffness
- FSTAB3** Heavy duty front stabiliser bar
- RAL21** Rear suspension load rating: 21,000 kg
- RAL23** Rear Axle Load 23 tonnes
- RAL26** Rear suspension load rating: 26,000 kg
- RSTAB1** Rear stabiliser bar
- RSTAB3** Heavy duty rear stabiliser bar
- RALIM105** Rear axle load limiter 10.5 tonnes (speed controlled)
- RALIM115** Rear axle load limiter 11.5 tonnes (speed controlled)
- RALIM13** Rear axle load limiter 13.0 tonnes
- RALIM15** Rear axle load limiter 15.0 tonnes
- RALIM95** Rear axle load limiter 9.5 tonnes
- ASF-DL1** Air Susp. Feature - 1 Driving Level
- ASF-DL3** Air Susp. Feature - 3 Driving Levels
- ACTST-TO** Volvo Dynamic Steering
- ASFE-BAS** Dynamic steering features - Standard
- ASFE-OG** Dynamic Steering Active Features - Oversteer Guidance
- ASFE-PO** Dynamic Steering Active Features - Personal Settings & Oversteer Guidance
- ASFE-PS** Dynamic Steering Active Features - Personal Settings
- PSS-DUAL** Power Steering System - Dual
- PSS-SING** Power Steering System - Single
- PSP-VAR** Power Steering Pump with Variable Displacement
- PSP-VAR2** Power Steering Pump with Electronic Control Variable Displacement
- EBS-MED** Electronic Brake System (EBS) contains ABS, Traction control, Hill start aid
Diff lock control, Brake assist
Wheel brake monitoring, EBS status
Electronic Brake System (EBS) contains ABS, Traction control, BCS
- EBS-STD**
- AUXPARK** Auxiliary parking brake
- RST-AIR** Rear Air Suspension
- FRAME300** Frame rail height 300mm
- FST8080** Frame Section Thickness 8mm
- FIL-EEEB** Liner (inner) from end of engine to end of bogie
- FIL-EEEF** Liner (inner) from end of engine to end of frame
- FIL-FBEB** Liner (inner) - front of bogie to end of bogie
- FIL-FBEF** Liner (inner)- front of bogie to end of frame
- FIL-TXEB** Liner (inner) - trans x-mem to end of bogie
- FIL-TXEF** Liner (inner) - trans x-mem to end of frame
- BBOX-L** Battery box mounted on LHS chassis rail
- 2BAT210B** Two Batteries 210 Ah Gel
- 2BAT210C** Two Batteries 210 Ah AGM
- 2BATT225** 2x225 Ah batteries
- BATTAMP** Battery Amperage Indicator (in the DID)
- BATTIND** Battery Charge Indicator (in the DID)
- ADR1** Standard ADR adaption - 1 switch

MODEL RANGE

FH16 8x4 Rigid Air Suspension FH 84RF 6A

<input type="checkbox"/> ADR2	Standard ADR adaption - 2 switches	<input type="checkbox"/> FFEND-T	2nd steer mudguard- transport mounted
<input type="checkbox"/> MSWI-A	Main Switch ADR	<input type="checkbox"/> RFEND-B	Rear Mudguards - Standard
<input type="checkbox"/> MSWI-C	Isolation Toggle Switch LHS of Chassis	<input type="checkbox"/> RFEND-T	Rear Mudguards - Transport
<input checked="" type="checkbox"/> MSWI-R	Isolation Switch on Key Fob (Press Door Lock Twice to Isolate)	<input type="checkbox"/> RFH-HIG	Highest Possible Mudguard Height
<input checked="" type="checkbox"/> UR-FUEL	Without RHS Fuel Tank Min volume 255l Max volume 810l	<input type="checkbox"/> RFH-LOW	Lowest Possible Mudguard Height
<input checked="" type="checkbox"/> UL-FUEL	LHS fuel tank not fitted Min volume 160l Max volume 450l	<input type="checkbox"/> ATANK-AL	Aluminium Airtanks
<input type="checkbox"/> ADTP-L	AdBlue Tank Position - LHS	<input type="checkbox"/> TL-LED	LED Tail Lights
<input checked="" type="checkbox"/> ADTP-R	AdBlue Tank Position - RHS	<input checked="" type="checkbox"/> BLIGHT-E	Emergency Brake Lights
<input type="checkbox"/> ADB032	AdBlue Tank 32 litres	<input type="checkbox"/> FRACLOS	With frame closing
<input type="checkbox"/> ADB048	AdBlue Tank 48 litres	Rims and Tyres	
<input type="checkbox"/> ADB064	AdBlue Tank 64 litres	<input type="checkbox"/> RT-AL	10 Stud Alloy Disc Rims (with long wheel studs)
<input type="checkbox"/> ADTC-BF	AdBlue Tank Cover - Bright Finish	<input type="checkbox"/> RT-AL1	10 Stud Alloy Level 1 Disc Rims (with long wheel studs)
<input checked="" type="checkbox"/> FCAP-L	Fuel Tank Cap with Lock	<input type="checkbox"/> RT-AL1DU	10 Stud Alloy Level 1 Disc Rims (with short wheel studs)
<input checked="" type="checkbox"/> FUFF-AS	Fuel Filling Feature - Anti Spillage	<input type="checkbox"/> RT-ALDP	10 Stud Dura-Bright Alloy Disc Rims (with long wheel studs)
<input type="checkbox"/> FUFF-ATS	Fuel Filling Feature - Anti Theft & Spillage	<input type="checkbox"/> RT-ALDPD	10 Stud Dura-Bright Alloy Disc Rims (with short wheel studs)
<input type="checkbox"/> ESH-LEFT	Muffler horizontal, left exhaust outlet	<input type="checkbox"/> RT-ALDU	10 Stud Alloy Disc Rims (with short wheel studs)
<input checked="" type="checkbox"/> ESH-REAR	Low Mounted Muffler with Low Rear Facing Outlet	<input checked="" type="checkbox"/> RT-STEEL	10 Stud Steel Disc Rims
<input type="checkbox"/> ESH-RIGH	Muffler horizontal, right exhaust outlet	<input type="checkbox"/> WCAP	Wheel caps
<input type="checkbox"/> ESH-VERT	Muffler horizontal, vertical exhaust outlet on right hand side	<input type="checkbox"/> SPWT-D	Spare rim & tyre equal to drive
<input type="checkbox"/> ESV-VERT	Single vertical exhaust/ vertical outlet	<input type="checkbox"/> SPWT-F	Spare rim & tyre equal to steer
<input type="checkbox"/> EXST-SSP	Stainless Steel Exhaust Stack	<input type="checkbox"/> SWCP-LF	Spare Wheel Carrier Front of Drive Axle. LHS
<input type="checkbox"/> WHC-FIX2	Two wheel chocks, fixed	<input type="checkbox"/> SWCP-T	Spare wheel supplied temporarily strapped to chassis
<input type="checkbox"/> WHC-FOL2	2 Wheel Chocks - Foldable	<input type="checkbox"/> SWCP-TP	Transport mounted spare wheel on top of frame
<input type="checkbox"/> WHCP-F	Wheel Chocks Position - Front of Chassis	<input type="checkbox"/> JACK-12T	12 tonne capacity jack with brace
<input type="checkbox"/> WHCP-R	Wheel Chocks Position - Rear of Chassis	<input type="checkbox"/> JACK-15T	15 tonne capacity jack and brace
<input type="checkbox"/> WHCP-T	Wheel Chocks Position - Transport Position in Cab	<input type="checkbox"/> JACK-20T	Jack - 20 Tonnes
<input type="checkbox"/> TB-L80	Toolbox 800 mm, left side	<input checked="" type="checkbox"/> TOOL-BAS	Basic tools
<input type="checkbox"/> TB-R80	Toolbox 800 mm, right side	<input type="checkbox"/> TOOLKIT	Tool kit complete
<input type="checkbox"/> SUP-BAS	Side underrun protection - standard	<input type="checkbox"/> INFLAHOS	Tyre inflation hose (18 metres)
<input type="checkbox"/> SUP-LOW	Side underrun protection - low	<input type="checkbox"/> GAUGE-TP	Tire pressure gauge
<input type="checkbox"/> CHAIN-S	Snow chains	Powertrain equipment	
<input type="checkbox"/> HOOK-SC	Hooks for snow chains	<input checked="" type="checkbox"/> TRAP-HD	Heavy Duty Transmission Internals
<input checked="" type="checkbox"/> TOWF-NO1	One Towing Device - Front	<input checked="" type="checkbox"/> DRM-BE	Drive Mode - Balanced & Economy
<input type="checkbox"/> TOWF-NO2	Two Towing Devices - Front	<input type="checkbox"/> PVT-BAS	Standard - by GPS positioning
<input type="checkbox"/> TOWMBRH	Tow member high mounting	<input type="checkbox"/> PVT-MAP	Map Based Topography Information (I-See Volvo Connect)
<input type="checkbox"/> TOWMBRL1	Tow member low mounting position 1	<input type="checkbox"/> CRUIS-E	Extended Cruise Control
<input type="checkbox"/> TOWMBRM	Tow member medium mounting	<input checked="" type="checkbox"/> CRUIS-E5	Extended Cruise Control (I-Torque with Additional Fuel Saving Functions)
<input type="checkbox"/> C-RI4040	Tow coupling Ringfeder 4040 G-150	<input type="checkbox"/> AMSO-AUT	Manual gear shift in automatic mode.
<input type="checkbox"/> C-RI4045	Tow coupling Ringfeder 4045 G-150	<input type="checkbox"/> AVO-ENH	AMT Vocational option - enhanced
<input type="checkbox"/> C-RI5050		<input type="checkbox"/> APF-ENH	Enhanced I-Shift PTO Functions
<input type="checkbox"/> C-RO400G	Tow coupling Rockinger 400 G150	<input checked="" type="checkbox"/> CS43B-O	Volvo 430mm single plate clutch
<input type="checkbox"/> C-RO50	Tow coupling Rockinger 50	<input type="checkbox"/> RET-TH	Retarder for manual gearbox Compact durable design with easy control
<input type="checkbox"/> C-VBG520		<input type="checkbox"/> TC-MAOH2	High performance transmission cooler
<input type="checkbox"/> C-VBG795		<input checked="" type="checkbox"/> TC-MWO	High performance transmission cooler
<input type="checkbox"/> TOWR-ONE	Single tow device	<input type="checkbox"/> TC-MWOH2	High performance transmission cooler
<input checked="" type="checkbox"/> TREL-PK	Trailer connection prep	<input type="checkbox"/> 2COM1080	High volume air compressor
<input type="checkbox"/> TREL14	14 pin elec. trailer connection	<input type="checkbox"/> 2COM1100	Air Compressor - 1100 litres/minute
<input type="checkbox"/> TREL15	15 pin elec. trailer connection	<input checked="" type="checkbox"/> 2COMP900	Air Compressor - 900 litres/minute
<input type="checkbox"/> TREL7	7 pin elec. trailer connection (24N)	<input type="checkbox"/> CLU-AIRC	Clutchable air compressor
<input type="checkbox"/> TREL7-7	2x7 pin elec. trailer connectors (24N & 24S)	<input type="checkbox"/> AIRIN-FR	Front Air Intake
<input type="checkbox"/> TRBR-HCF	Hand controlled trailer brake, full pressure	<input checked="" type="checkbox"/> AIRIN-HI	High air intake, roofline position
<input type="checkbox"/> TRBR-HCR	Hand controlled trailer brake, reduced pressure	<input type="checkbox"/> AIRIN-LO	Low air intake, rear of cab position
<input type="checkbox"/> TRBR-STA	Stationary Trailer Brake Control	<input type="checkbox"/> ACL1ST-S	Air cleaner with two stage filter element
<input type="checkbox"/> TRB-STRE	Automatic Trailer Brake Activation (Stretch Brake)	<input type="checkbox"/> 24A150BL	Alternator - 150 Amp
<input type="checkbox"/> RUP-FOSL	Rear underrun prot. - foldable sliding	<input checked="" type="checkbox"/> 24A180BL	Alternator - 180 Amp
<input type="checkbox"/> FFEND-B	2nd steer mudguard- standard	<input type="checkbox"/> 24AL150B	Alternator - 150 Amp

Standard Equipment Optional Equipment

For more detailed information about cab and powertrain equipment, please refer to separate specification sheets.

For all possible options and combinations of options please consult your Volvo sales contact who can create a specification to match your requirements using the Volvo Sales Support system (VSS).

The factory reserves the right to modify design and change equipment without previous notification. The specification can vary from country to country.

MODEL RANGE

FH16 8x4 Rigid Air Suspension FH 84RF 6A

- **PRIM-EL** Pump Prime - Electrical
- **AF-E** Auxiliary fuel filter, electrically heated
- **AF-R** Recirculation heated fuel filter
- **FUEFE2LW** Dual fuel filter, engine mounted with water separator-large
- **FUEFE2SW** Dual fuel filter, engine mounted with water separator-small
- **EST-AID** Engine starting aid
- **220EBH15** 220V/1.5kw engine block heater
- **PTER-100** PTO Engine Rear Mounted with Flange DIN100/ISO7646
- **PTER-DIN** Power Take Off / splined shaft groove (female) DIN5462.
- **PTER1400** Rear engine mounted power-take-off with flange SAE 1410
- **HPE-F101** F1-101 Hydraulic pump rear engine mounted
- **HPE-F41** F1-41 Hydraulic pump rear engine mounted
- **HPE-F51** F1-51 Hydraulic pump rear engine mounted
- **HPE-F61** F1-61 Hydraulic pump rear engine mounted
- **HPE-F81** F1-81 Hydraulic pump rear engine mounted
- **HPE-T53** F2-53/53 twin flow hyd pump rear engine mounted
- **HPE-T70** F2-70/53 twin flow hyd pump rear engine mounted
- **HPE-V45** V1-45 variable pump rear engine mounted
- **HPE-V75** V1-75 variable pump rear engine mounted
- **PTR-D** Low speed PTO with DIN connection
- **PTR-DH** High speed PTO with DIN connection
- **PTR-DM** Medium speed PTO with DIN connection
- **PTR-F** PTO Flange Connection - Low Speed
- **PTRD-D** PTO 2 DIN Connections - (Front & Rear)
- **PTRD-F** PTO with 1 flange connection
- **HPG-F101** F1-101 Hydraulic Pump
- **HPG-F41** F1-41 Hydraulic Pump
- **HPG-F51** F1-51 Hydraulic Pump
- **HPG-F61** Parker F1-61 hydraulic pump (transmission mtd)
- **HPG-F81** F1-81 Hydraulic Pump
- **STWM-LE** Steering Wheel Material - Leather
- **DRC-AMI** DPF Regeneration- Auto Initialise/Manual on Demand/Manual Inhibit
- **1DAYB** 1DAY-STD/SI-GRAF/basic setting
- **1DAYDIG** 1DAY-STD/SI-GRAF/digital
- **1DAYDIG4** Gen 4 One-Day Digital Tachograph (EC Approved)
- **ARSL** Additional road speed limiter
- **ACCLF-D** Acceleration Limiting Feature - Disabled
- **ESP-BAS1** ESP Package (Tractor/Trailer Combinations with ABS/EBS Or Rigid with Standard COG)
- **ESPC-RO** ESP functionality control reduced/off
- **HWSS-ACB** ACC & forward collision warning & emergency braking.
- **HWSS-FCB** Forward Collision Warning including Emergency Braking
- **LSS-DW** With lane departure system
- **LSS-DW3** Pilot Assist - Active Continuous Lane Keeping
- **LCS2** LCS with Side Collision Avoidance Support (LHS)
- **LCS3** LCS with Side Collision Avoidance Support (LHS) & Emergency Braking
- **LCS4** Lane Change Support with Side Collision Warning (Both Sides)
- **LCS5**
- **DAS-W** Driver alert support warning
- **DAS-W2** Driver Alert Sensing System (monitoring of vehicle handling & driver attention)
- **PB-AUT2** Park Brake Applied Automatically When Driver Leaves Seat
- **RSENS-W** Rain Sensor to Activate Wipers
- **CU-ECC** Climate controlled air conditioning
- **CU-ECC2** Electronically Controlled Air Conditioning with Air Quality Sensor & Carbon Filter
- **CU-MCC** Manual controlled air conditioning
- **IGT-BUT** Ignition Type - Push Button
- **IMMOBIL** Engine Immobiliser
- **ALARM-E** Anti-theft alarm (cab & body/trailer)
- **ALCOLOCK** Alcolock
- **AUD-EXT** Audio Extended
- **BUPMON** Back-Up Camera
- **ISUNS-BS** Interior Side Sunvisor - Both Doors
- **ISUNS-DS** Interior Side Sunvisor - Driver's Door
- **ISUNF-RE** Windscreen Interior Sunvisor - Electric
- **ISUNF-RM** Windscreen Interior Sunvisor - Manual
- **CSPL-BX** Centre Section Dash Panel Shelf
- **CSPL-BXD** Centre section dash panel pull out drawer
- **ADFS** 2 Din Slots in Front Shelf
- **BUPALARM** Reverse alarm
- **RTOLL-PK** Road toll prep kit
- **LOADIND** Load indicator, electronic controlled suspension (SUSPL-EC)
- **REMC-MF** Multifunction Wireless Remote Control
- **FIREX3FR** Fire extinguisher, 3 kg, French decal
- **FIREX2F** Fire extinguisher, 2 kg, French decal
- **FIREX2G**
- **FIREX3D** Fire extinguisher, 3 kg, Danish decal
- **FIREX3F** Fire extinguisher, 3 kg, Finnish decal
- **FIREX3N** Fire extinguisher, 3 kg, Norwegian decal
- **FIREX3P** Fire extinguisher, 3kg, Portuguese decal
- **FIREX3R**
- **FIREX3S** 3kg fire extinguisher
- **WARNVEST** Warning vest
- **WARNTRI2** 2 warning triangles
- **AIDKIT** First aid kit
- **AIDKIT1B** First aid kit-German market demands
- **WARNLAMP** Portable warning lamp
- **LAMP-IN** Inspection lamp
- **BULBKIT** Bulb and fuse kit
- **WRITEPAD** Writing pad
- **DST-CF1** Driver seat comfort suspended
- **DST-CF4** Fully adjustable driver's comfort seat Air suspension
- **DST-CF5** Fully adjustable driver's comfort seat Air suspension, heated, integrated safety belt
- **DST-CF6** Fully adjustable driver's comfort seat Air suspension, integrated safety belt
- **DST-LUX1** Driver seat, lux, susp, belt, heat, vent
- **DST-LUX2** Driver seat, lux, susp, belt, heat
- **DST-STD2** Driver seat standard, suspended
- **SBD-RED** Red safety belts, pass. & driver seats
- **SBPRE-DS** Drivers seat belt pretensioner
- **PST-BAS1** Basic passenger's seat
- **PST-CF4** Fully adjustable passengers comfort seat Air suspension, integrated safety belt
- **PST-CF5** Fully adjustable passenger comfort seat Air suspension, heated, safety belt
- **PST-RX1** Passenger relax seat with swivel and tilt
- **PST-STD2** Passenger Seat Basic 2 Armrests
- **PST-STD4** Passenger Seat Basic 2 Armrests Susp
- **SBPRE-PS** Passenger Seatbelt Pretensioner
- **ARMRE-BB** Armrests both sides - driver's & passenger's seat
- **ARMRE-DB** Armrests both sides - driver's seat
- **ARMRE-PB** Armrests Both Sides - Passenger's Seat
- **ARU-BAS** Seat armrest upholstery - basic
- **ARU-LEA** Seat Armrest Upholstery - Leather
- **GRABHI-B** Instep Grab Handle - Standard

■ Standard Equipment □ Optional Equipment

For more detailed information about cab and powertrain equipment, please refer to separate specification sheets.

For all possible options and combinations of options please consult your Volvo sales contact who can create a specification to match your requirements using the Volvo Sales Support system (VSS).

The factory reserves the right to modify design and change equipment without previous notification. The specification can vary from country to country.

MODEL RANGE

FH16 8x4 Rigid Air Suspension FH 84RF 6A

■ GRABHI-L	Instep Grab Handle - Leather Bound	□ CTILTP-E	Electrical Cab Tilt Pump
□ FMAT-RUB	Floor Mats - Rubber	■ CTILTP-M	Manual Cab Tilt Pump
■ FMAT-TX2	Floor Mats - Textile & Rubber	□ FCABS-A	Front Cab Suspension - Air Bellows
■ LBK80F	Lower Bunk 815mm Wide	■ FCABS-M	Front Cab Suspension - Mechanical Spring
□ LBK80FRE	Lower Bunk 815mm Wide - Electrically Reclinable	□ RCABS-A	Rear Cab Suspension - Air Bellows
□ LBK80FRM	Lower Bunk 815mm Wide - Manually Reclinable	■ RCABS-M	Rear Cab Suspension - Mechanical Spring
□ MATL-FI	Spring Mattress Lower Bunk - Firm (100kg +)	■ HCC-EXT	Front hatch catch control-electric
□ MATL-FI4	Foam Mattress Lower Bunk - Firm (100kg +)	■ HCC-INEX	Front hatch catch control-manual
■ MATL-SF	Mattress lower bunk - semi firm	□ MIRCFPCS	Electrically Heated & Operated Convex Glass Mirrors with Front Monitoring Camera on Passenger Side
□ OLMAT-BA	Mattress overlay - basic	□ MIRCMCP	Camera Monitor System & Blind Spot Camera - Without Exterior Mirrors
■ OLMAT-PR	Mattress Overlay - Premium	□ MIRCMS	Camera Monitor System - Without Exterior Mirrors
□ TBK60AD	Top bunk 600mm wide, foldable & height adjustable	■ MIRCOMF	Electrically heated and operated exterior mirrors with wide angle mirrors on both sides and close view mirror on passenger side.
□ TBK60F	Top bunk 600mm wide, foldable	■ AMIR-F20	Close view mirror
□ TBK70AD	Top Bunk 700mm Wide - Foldable & Height Adjustable	□ SUNV-H	Exterior Sunvisor
□ TBK70F	Top Bunk 700mm Wide - Foldable	□ AD-ROOF	Aero-dynamic roof mounted deflector
□ PH-CAB2	Cab Parking Heater 2kw	□ AD-SIDES	Aero-dynamic cab side deflectors
□ PH-ENGCA	Cab and engine parking heater	□ HL-BASIC	Standard head lamps
■ SLCP-BAS	Sleeper Control Panel - Standard	■ HL-LED	LED Headlights
□ SLCP-LUX	Sleeper control panel	□ HL-LED3	LED Headlights with Adaptive High Beam
□ SAFE	Safe box at bed-end	■ HL-CLEAN	Head lamp cleaning system
□ RUS-BAS	Rear Upper Cab Storage - 154 Litres for Sleeper/Globetrotter & 60 Litres for Day Cab	□ HLP-ST	Headlight Protection - Steel
□ RUS-HIG	Rear Upper Cab Storage - 245 Litres	□ HL-ADJ	Headlight Adjustment - Manual
□ TABLE	Table	■ DRL-LED	V-shaped LED Daytime Running Light
□ REFR-RUS	28 Litre Refrigerator in Upper Rear Storage	□ DRIVL2	Integrated driving lamps
□ REFRIG	33 Litre Refrigerator Under Lower Bunk	■ UDRIVL	Without Integrated Driving Lights
□ MICRO-PK	Preparation Kit for Microwave	■ FOGL-WC	Integrated fog lamps
□ BOTH-D	Bottle Holder in Driving Area	□ CL-STAT	Corner light-static
□ BOTH-DL	Bottle Holder in Driving & Resting Areas	□ ASL-RF2	Spotlights Inside Globetrotter Sign Box
□ BOTH-L	Bottle Holder in Resting Area	□ IDLAMP-A	Identification Lamps - Amber
□ COFMA-PK	Coffee maker prep kit	□ IDLAMP-W	Identification Lamps - white
□ SOL12S	12v Outlet in Sleeper Area	□ IDLMPSW	Switch in cab for identification lamps
□ INLI-BAS	Interior night lights	□ BEACOA2F	2 Amber Rotating Lights- Front of Roof
□ INLI-NL	Interior White & Red (night) Light	□ BEACOA2R	2 amber rotating lights- rear of roof
■ INLI-NLD	Interior light including night light and dimmer function	□ BEACON-P	Beacon Light Wire Preparation
□ ARL-FLEX	Flexible Reading Lamp (Snake Light)	□ BEACON4	4 amber rotating lights
■ RH-EE	Sky Window - Emergency Exit Roof Glass (tinted)	□ CABPT-R1	1 cab roof pass through on driver's side
□ RH-ER	Roof Hatch - Electric (Metal Emergency Exit)	■ CABPT-R2	2 cab roof pass throughs, 1 on each side
□ RH-ETR	Roof Hatch - Electric (Tinted Glass & Rear Opening)	□ SPOTP-F	Aux spotlight preparation, 280W maximum
□ RH-MTR	Roof Hatch - Manual (Tinted Glass & Rear Opening)	□ SPOTP-R	Spot light preparation on roof, max 280W
□ GLAS-UNT	Clear window glass	□ SPOTP-RF	Spot light preparation in front and on roof, max 280W
□ SWIND-BS	Cab side window-both sides	□ ROS-IL	Illuminated roof sign
■ VANMIR	Vanity Mirror	□ ROS-IL2	Illuminated Cab Sign Prep Kit
□ AS-FUS	Auxiliary Shelf - Front Upper Storage	□ ROS-ILP	Illuminated Cab Sign Prep Kit
□ INFOT-PK	LCD screen mount - 6kgs max	□ CSGN-ENG	Cab sign - Globetrotter
Cab exterior		□ CSGN-GTR	Globetrotter Decal
□ EXTL-BAS	Standard Exterior Trim Level	□ HORN-F1S	Single Electric Jericho Air Horn (Behind Grill)
■ EXTL-EN3	Enhanced Exterior Trim Level 3	□ HORN-R2S	Chromed air horns, two roof mounted
■ DGLAS-H	Hardened Door Glass	□ ANT-CBR	Antenna for CB Radio (Single Antenna)
□ DGLAS-L	Laminated Door Glass	□ ACCBP-AP	Accessory bracket-forward, mid & rearward roof mounted
■ BUMP-B	Bumper - Plastic	□ ACCBP-F	Accessory Bracket - Forward Roof Mounted
□ BUMP-B2	Bumper - Steel	□ ACCBP-FM	Accessory Bracket - Forward & Mid Roof Mounted
□ BUMP-HD	Bumper - Heavy Duty	□ ACCBP-FR	Accessory bracket-forward & rearward roof mounted
■ BUMP-SP	Bumper spoiler	□ ACCBP-M	Accessory Bracket - Mid Roof Mounted
□ AUXFS	Auxiliary Folding Side Step	□ ACCBP-R	Accessory bracket-rearward roof mounted
□ GUARD-EH	Guard plate for cooling pipes and oil sump	□ ACCBP-RM	Accessory bracket-rearward & mid roof mounted
■ BUGNET	Insect Net in Front of Radiator		

■ Standard Equipment

□ Optional Equipment

For more detailed information about cab and powertrain equipment, please refer to separate specification sheets.

For all possible options and combinations of options please consult your Volvo sales contact who can create a specification to match your requirements using the Volvo Sales Support system (VSS).

The factory reserves the right to modify design and change equipment without previous notification. The specification can vary from country to country.

MODEL RANGE

FH16 8x4 Rigid Air Suspension FH 84RF 6A

- **STUC-B** Storage Compartment Under Cab - Both Sides
- **STUC-L** Storage Compartment Under Cab - LHS
- **STUC-R** Storage Compartment Under Cab - RHS
- **REFS-TW** Reflecting stripes transport mounted on cab - white
- **REFS-TY** Reflecting stripes transport mounted on cab - yellow

Superstructure

- **SRWL-2RW** 2 Rear Chassis Mounted Working Lights - White
- **SRWL-PK** Wiring Prep for Chassis Mounted Working Lights - 3 Position Switch
- **SWL-2FW** 2 Side Working Lamps - White (Forward Facing)
- **SWL-2RW** 2 Side Working Lamps - White (Rearward Facing)
- **SWL-4W** 4 Side Working Lamps - White
- **SWL-PK** Wiring Prep for Chassis Mounted Working Lights - 2 Position Switch
- **WL-CHPK** Chassis Mounted Working Light Prep Kit
- **WLC-H2W** 2 LED Work Lights - High Mounted
- **WLC-PKH** Prep Kit for High Mounted Work Lights
- **WLC-PKL** Prep Kit for Low Mounted Work Lamps
- **WLC-PKLH** Prep Kit for Low and High Mounted Work Lamps
- **ECBB-BAS** B/B Elect. Centre without B/B Module
- **ECBB-HIG** Body Builder Module - Cab Module (14 High/4 Low)
- **BBCHAS1** Body Builder Chassis Electrical Interface - 1 x 7 Pin Connector
- **BBCHAS3** Body Builder Chassis Electrical Interface - 3 x 7 Pin Connectors
- **BEPR-T2** Body Builder electrical prep. for tipper with remote control
- **EXSTER** External Steering via Body Builder's Module
- **TD-LED** LED trailer detection sensor
- **FRFS-BS** Frame Rail Free Space - Both Sides
- **FBA-BTF** Front body attachment- flexible
- **FBA-BTSF** Front body attachment-semi flexible
- **HBA-FSFB** Holes for Body Attachments, Flexible & Semi Flexible
- **HBA-SB** Holes for Body Attachments
- **RBA-T2** Rear body attachment type 2-divided
- **CRANEPK1** Crane interface for capacity up to 10t
- **CRANEPK2** Crane interface for capacity up to 20t
- **CRANEPK4** Crane interface for capacity up to 40t
- **AUXL-SPK** Aux. lamps snow ploug prep kit
- **TAILPRE2** Taillift preparation kit for wireless remote
- **TAILPREP** Taillift preparation kit
- **AESW2** 2 Flexible Switches (AUX1 and AUX2).
- **AESW2PK** 2 Flexible Switches (AUX1 & AUX2) + Additional 4 Flexible Switches
- **AUXSW-4** Wiring Prep. for 4 Extra Bodybuilder Switches (switches not included)

Delivery services

- **TGW-4GWL** Telematics Gateway with 4G/LTE & WLAN
- **TGW-PK** Telematics gateway prep kit
- **FMS-PK** Fleet Management System Gateway
- **DRUT1** "My Truck" Smartphone App. 1 Year Prepaid
- **DRUT2** "My Truck" Smartphone App. 2 Year Prepaid
- **DRUT3** "My Truck" Smartphone App. 3 Year Prepaid
- **DRUT4** "My Truck" Smartphone App. 4 Year Prepaid
- **DRUT5** "My Truck" Smartphone App. 5 Year Prepaid
- **TSRS** Traffic Sign Recognition System (ISA Compliant)
- **TSRS2** Traffic Sign Recognition System

Volvo Trucks. Driving Progress