

ecomaxTM
by **HOBART**

DISHWASHER
F504



 made in germany

ECOMAX F504 DISHWASHER



With a high capacity of up to 60 racks per hour, this dishwasher is a reliable partner for club houses, bistros, and fast-food restaurants. The practical floor unit fits under every work counter.

Dishwasher ecomax F504

| | |
|------------------------------|----------------------------|
| Cycle times* | 60 / 150 sec. |
| Capacity per hour* | up to 60 racks |
| Wash/rinse temperature | approx 60° C / approx 82°C |
| Tank capacity | 25 l |
| Fresh water consumption/rack | 2.3 l |
| Wash pump | 0.34 kW |
| Heating booster/tank | 1.9 kW / 1.8 kW |
| Total loading | 2.4 kW |
| Rated voltage | (240 / 50 / 1)-15A |
| Width/Depth/Height | 576/604/820 mm |
| Loading height | 360 mm |
| Rack size | 500 x 500 mm |

*hot water connection **with 230V/50Hz/1/N

The installation of machines with integrated water softener requires a back flow safety device (at site) according to DVGW-DIN 1988. Line pressure required: 0.8 to 6 bar

PRODUCT ADVANTAGES

- Electronic control with digital temperature indication
- Flat surface of control panel
- 2 selectable wash cycles
- Rotating top and bottom wash system to distribute the wash water evenly over the dishes
- Indented nozzles prevent blocking
- Thermostop-function for guaranteed rinse temperatures
- Integrated self-cleaning cycle
- Removal of rinse arms without any tools
- Easy access to all parts
- Deep drawn rack track
- Door safety lock
- Double-walled insulated front door
- Tank strainer reduces soiling of the tank water
- Integrated cycle counting, e.g. for control of water treatment system
- USB connect for easier service access

STANDARD EQUIPMENT

- Plate rack P-18-12
- Cutlery basket CB1
- Rinse aid dispenser
- Rinse pressure pump for optimum flow pressure
- Heater with thermostat control
- Electric cable, flexible water supply hose and drain hose
- Rear panelling

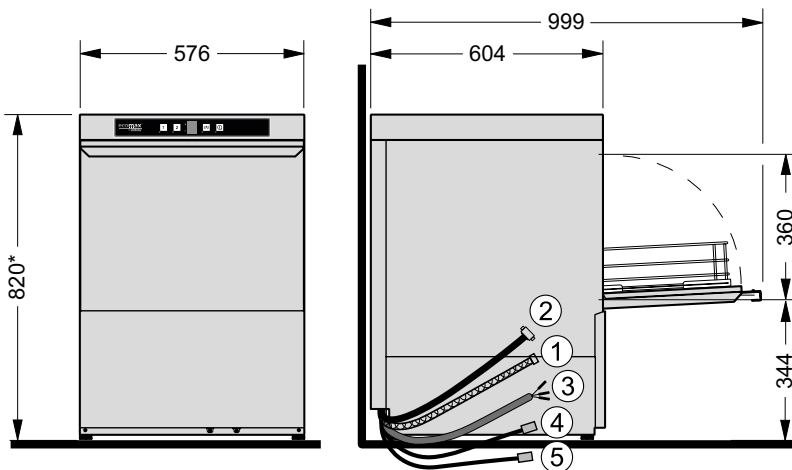

* + 40 mm adjustable feet

CONNECTIONS

| | |
|-------------------------------|--------------------------|
| ① Drain hose | 2,000 mm ID20/OD25 |
| ② Supply hose | 2,000 mm R 3/4" |
| Flow pressure | 3.0 -6 bar (300-600 kPa) |
| Max. supply water temperature | 60°C |
| Required flow rate | 5 l/min |
| ③ Power cord | 2,000 mm |
| Supply hose for | |
| ④ Detergent | 2,500 mm |
| ⑤ Rinse aid | 2,500 mm |