



S120E

Modular electric oven for pizzeria

COMPOSITION WITH 2 BAKING CHAMBERS



OPTIONS AND ACCESSORIES (WITH SURCHARGE)

- Leavening prover on wheels, height 800mm
- Leavening prover on wheels, height 600mm
- Support with wheels, height 600mm
- Support with wheels, height 800mm
- Additional tray holder guides for compartment and support

EXTERNAL CONSTRUCTION

- Structure made in folded stainless steel
- Side panels in pre-painted sheet metal
- Channel hood with a variable power extractor
- Front vapour collection hood in stainless steel sheet with tempered silk-screen printed glass logo
- Steam duct in stainless steel plate
- Stainless steel door with bottom hinge and spring balance
- Tempered glass element
- Door handle in stainless steel
- Control panel on front right hand side

INTERNAL CONSTRUCTION

- Refractory brick cooking surface
- Aluminated steel top and side structure
- Dual halogen lighting
- Rock wool heat insulation

FUNCTIONING

- Heated by armoured heating elements
- Temperature management using P.I.D. (Proportional Integrative Derivative) permit the automatic energy regulation to the quantity of the baked product ADAPTIVE-POWER® TECHNOLOGY
- Separated temperature management of ceiling and floor DUAL-TEMP® TECHNOLOGY
- Separated power management of ceiling and floor SMART-BAKING TECHNOLOGY
- Automatic cleaning program for carbonization
- Maximum temperature reached 450°C
- Continuous temperatures monitoring in cooking chamber by 2 thermocouples
- Vapour ducting using manual butterfly valve

STANDARD EQUIPMENT

- Color multilanguage LCD display
- 100 customized programs
- Eco-Stand by function for break
- Booster function for workload peaks
- Partial load function
- Customized Hotkey with recurring control
- Self-diagnosis with error message display
- Cooking Timer
- Weekly Timer with the possibility to program two lightings and two power off every day
- Independent security device of maximum temperature
- USB slot for data reading/input DATA-FEED® SYSTEM



MORETTI FORNI S.P.A.

www.morettiforni.com

marketing@morettiforni.com

Via A.Meucci, 4 - 61037 Mondolfo (PU) ITALIA

Tel. +39.0721.96161 - Fax +39.0721.9616299



S120E

2 baking chambers height 16cm

(assembled with support height 800mm)

TOP VIEW

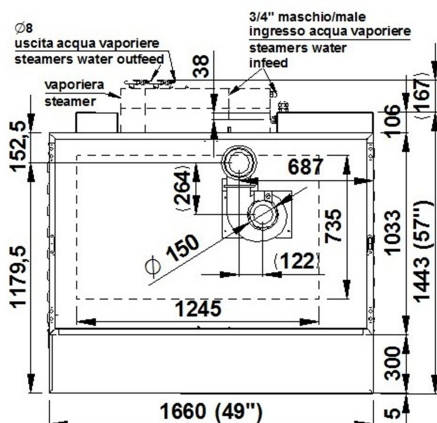

REAR VIEW

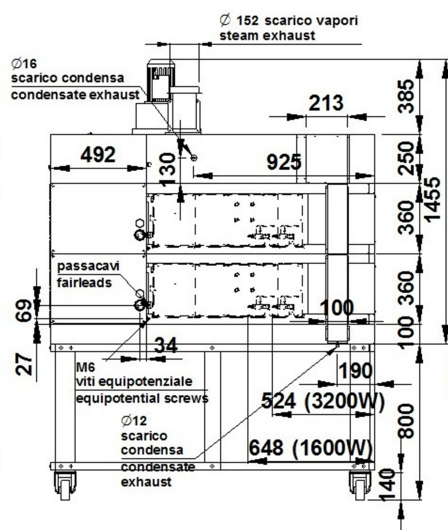

RIGHT SIDE VIEW

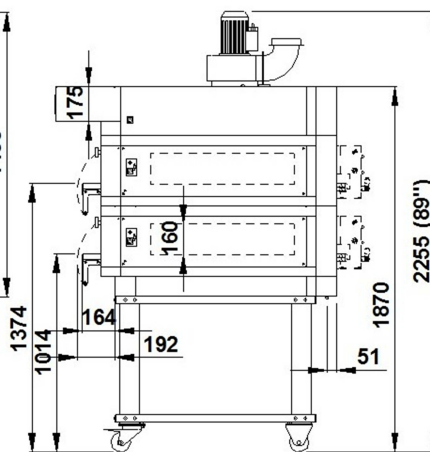

Note: The dimensions indicated in the views are in millimetres. Steamer for Bakery only.

SPECIFICATIONS

The appliance comprises two independent cooking elements and an optional leavening compartment or support. The oven cooking surface is made of refractory, allowing perfect heat distribution over the whole surface and making this oven particularly suitable for use by pizza cooks. Temperature adjustment is electronic, with independent control of the ceiling and floor heating elements. The oven door is hinged at the bottom, with a tempered glass window to check the state of the product while it is cooking. The support comprises a painted metal structure, whereas the leavening compartment has a stainless steel structure and is fitted with a heating thermostat. The leavening compartment can reach a maximum temperature of 65°C, whereas the maximum temperature of the baking chamber is 450°C

All the data provided below refer to the configuration with 2 baking chambers

DIMENSIONS

External height	1170mm
External depth	1032mm
External width	1660mm
Weight	365kg
Baking surface	1,8m ²

SHIPPING INFORMATION

Packed in wooden crate	
Height	1320mm
Depth	1400mm
Width	1870mm
Weight	(365+10)kg

FEEDING AND POWER

Standard feeding	
A.C. V400 3N	
Feeding on request	
A.C. V230 3	
Frequency	50/60Hz
Max power	24kW
Average power cons	8kWh
Connecting cable for each chamber	
type H07RN-F	
5x4mm ² (V400 3N)	
4x6mm ² (V230 3)	
Power supply (optional prover)	
A.C. V230 1N 50/60 Hz	
Max power	1,5kW
Average power cons	0,8kWh
Conn. Cable type	H07RN-F
3x1,5mm ²	

TOTAL BAKING CAPACITY

Tray (600x400)mm	6
Pizza diameter 350mm	12
Pizza diameter 450mm	6

When combined with leavening compartment or support:	
Max height	2400mm
Max weight	(480+10)kg

* This value is subject to variation according to the way in which the equipment is used

- NOTE: MORETTI FORNI S.P.A. reserves the right to modify the characteristics of the products illustrated in this publication without prior notice