

1000 Series Ram End Formers

**For most endforms up to 1" (26mm)*

Model 1005HY

The **newly redesigned** 1005HY Hydraulic End Forming Machine has 6.5 tons of ram force and 9 tons of tube clamp force, similar to our previous 1000 series end formers. New to this machine is an increased ram velocity of 11" per second, compared to the previous 8.5" per second, which provides users with a cycle rate improvement. With the addition of two ram strokes, this 5-hit machine provides more versatility and flexibility than our previous model.

**Maximum tube diameter is dependent upon endform type, and tubing material type, grade, and wall thickness.*

FEATURES & BENEFITS

Part Builder

- Capable of saving multiple part setup parameters
- When saved parts are selected, the number of hits and lubrication points (if applicable) are recalled
- Improve setup consistency, save time, and reduce the occurrence of setup errors

Programmable Retract Stroke Control

- Results in increased part output

Variable Frequency Drive Controlled Hydraulic Unit

- Less power consumption
- Quieter operation

Ergonomic Frame Design

- Ideal for a narrower cell footprint
- Easier access for tooling change-over and maintenance
- Light bar illuminates workspace

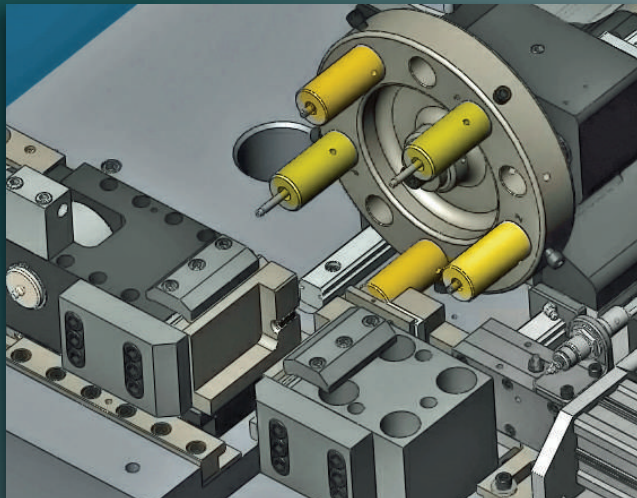

Model 1005HY

WAUSEON MACHINE

1000 Series

Ram End Formers

**For most endforms up to 1" (26mm)*

STANDARD FEATURES

- Part Builder (part parameter setup storage)
- Graphical user interface
- Automatic drop-out
- Interior light bar
- High speed hydraulic unit
- High speed stepper driven turret

OPTIONS

- Auto load/unload systems
- Light curtains
- Part lubrication systems
- Opti-touch cycle start
- Custom paint color
- Servo driven precision tube stop locator
- 4" Ram Stroke

SPECIFICATIONS

Ram Force	6.5 tons
Tube Clamp Force	9 tons
# of Ram Strokes	5
Hydraulic Unit	7.5 HP, 15 GPM
Working Pressure / Max. Pressure	1200 / 2650 psi
Ram Cylinder (bore)	2.50"
Ram Stroke	3"
Max. Clamp Opening	1.50"
Cycle Rate	1.6 to 3.8 seconds <i>(endform dependent)</i>
Air Requirements	80 psi, 2 cfm
Electrical Requirements	460 VAC, 3 phase, 60 hz 20 amps
Weight	1960 lbs
Color	Standard Blue

**Maximum tube diameter is dependent upon endform type, and tubing material type, grade, and wall thickness.*

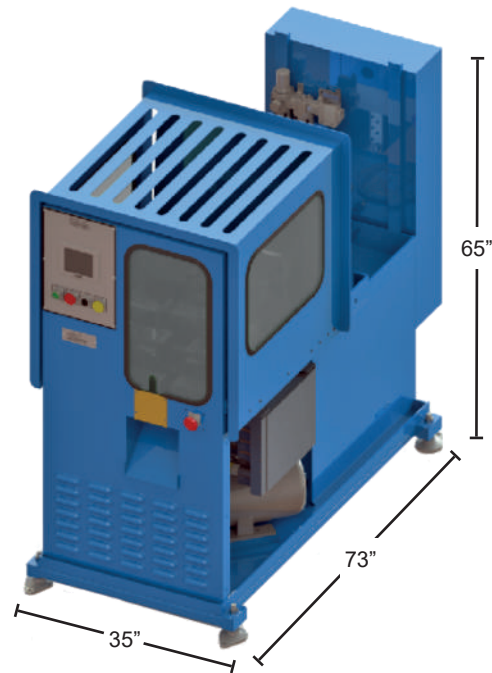

Model 1005HY Footprint
35"W x 73"D x 65"H

Innovative Production Machines for the Tube Fabrication Industry



Wauseon Machine and Manufacturing, Inc.

995 Enterprise Avenue

Wauseon, Ohio 43567

419-337-0940

www.wauseonmachine.com

sales@wauseonmachine.com