

All materials specified are to comply with the requirements of the applicable standards.

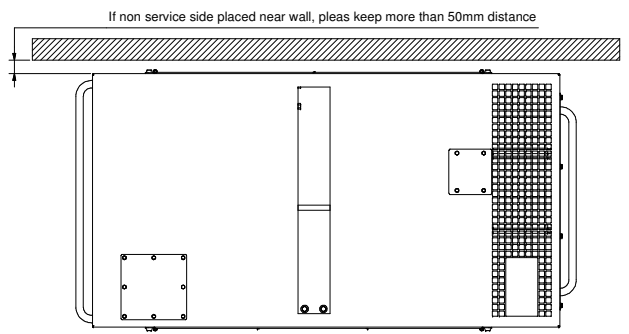
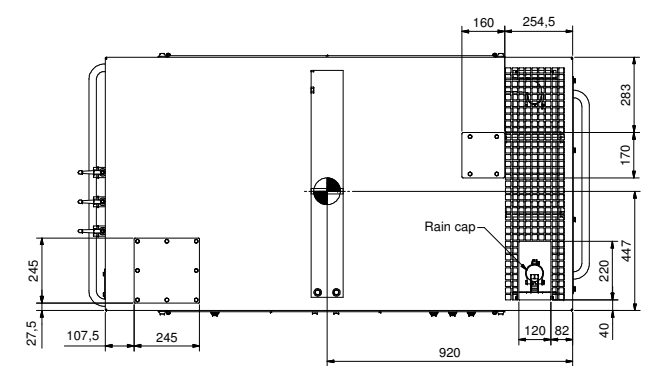
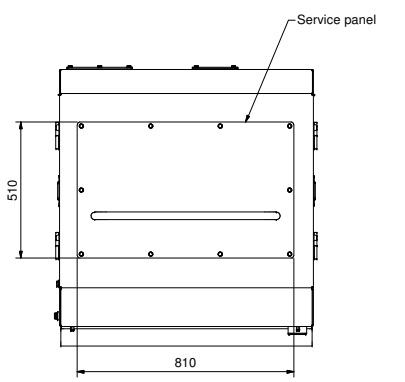
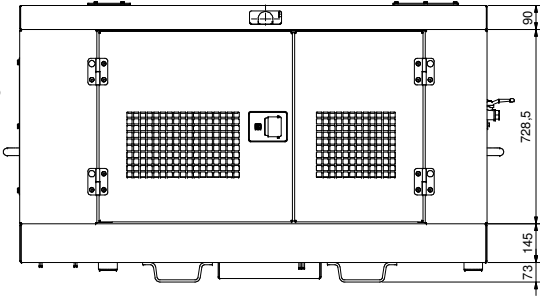
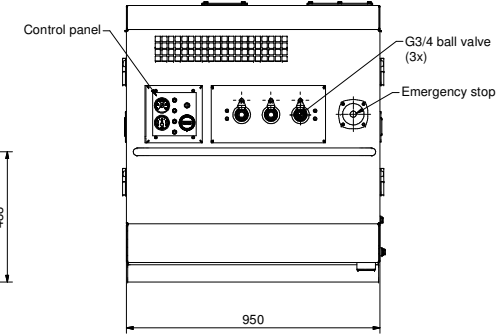
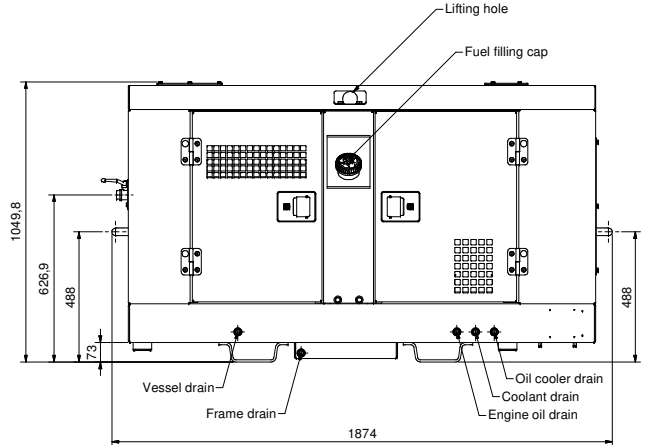
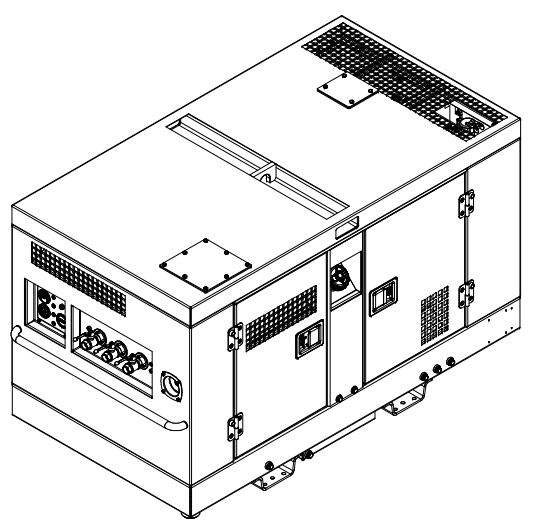
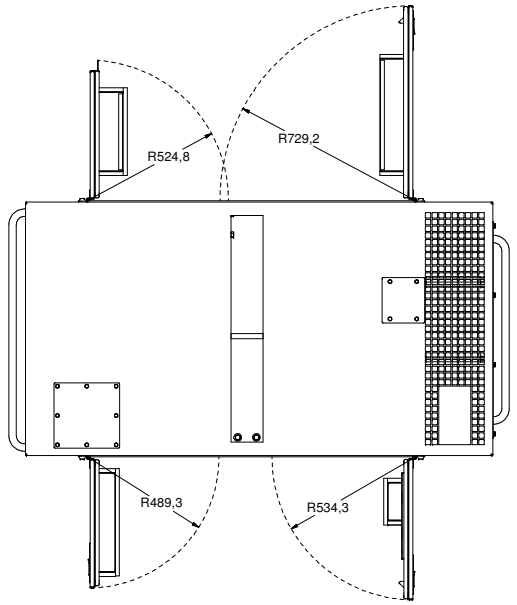
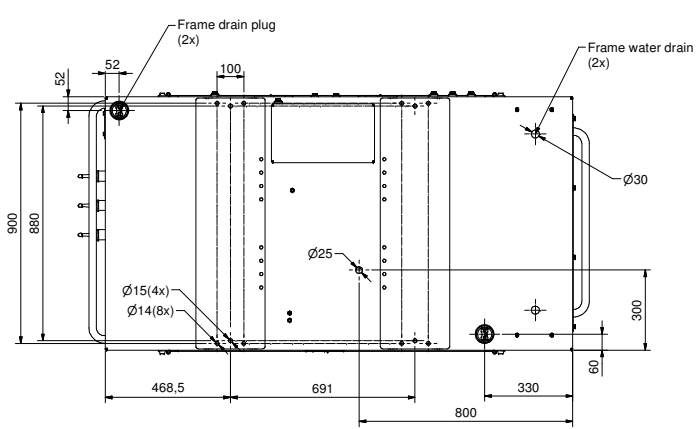

		Center of gravity																							
Net Mass	Xz	Yz	Zz	Wet Mas	Xz	Yz	Zz																		
kg	mm	mm	mm	kg	mm	mm	mm	mm	mm																
650	920	400	382	720	920	420	390																		
<b>Type</b>				<b>BOX</b>																					
<b>Commercial Name</b>				<b>U190 KD/U175 KD/U130 KD</b>																					
<b>Total max. Weight</b>				<b>720kg</b>																					
Tolerances, if not indicated, according to: General tolerances: 1350K - m																									
ATLAS COPCO STANDARD CLASS																									
<b>Name</b> DIMENSION DRAWING								Consistency Draw see 110174																	
<b>Material</b> Not Applicable								Confidential																	
<b>Treatment</b> Not Applicable								INV																	
<table border="0"> <tr> <td>Scale</td> <td>1:10</td> <td>Family</td> <td></td> <td>Compare</td> <td></td> <td>Drawing owner</td> <td></td> </tr> <tr> <td>Drawn by</td> <td>WUX0996</td> <td>Blank nr.</td> <td></td> <td>Replaces</td> <td></td> <td>WUX</td> <td></td> </tr> </table>										Scale	1:10	Family		Compare		Drawing owner		Drawn by	WUX0996	Blank nr.		Replaces		WUX	
Scale	1:10	Family		Compare		Drawing owner																			
Drawn by	WUX0996	Blank nr.		Replaces		WUX																			
<table border="0"> <tr> <td>Drawing format</td> <td>Blank wt</td> <td>Paper wt.</td> <td>N/A</td> <td>Designation</td> <td></td> <td>Sheet</td> <td>1 / 1</td> </tr> <tr> <td>Des. checked</td> <td>AI</td> <td>kg</td> <td></td> <td>Date</td> <td>6/13/2017</td> <td colspan="2"><b>9829387700</b></td> </tr> </table>										Drawing format	Blank wt	Paper wt.	N/A	Designation		Sheet	1 / 1	Des. checked	AI	kg		Date	6/13/2017	<b>9829387700</b>	
Drawing format	Blank wt	Paper wt.	N/A	Designation		Sheet	1 / 1																		
Des. checked	AI	kg		Date	6/13/2017	<b>9829387700</b>																			

CONFIDENTIAL: This document is property of Atlas Copco and its subsidiaries. All rights reserved. No part of this document may be reproduced without the prior written permission of Atlas Copco. The information contained herein is for internal use only.

Ed.	Position	Modified from	Date	Intr./Appd.

9829387700	00.00
Parent 3D model	Ed. - Version 3D

Preliminary	3D/112	AI	kg	N/A	Designation	Sheet	1 / 1
Des. checked	Prod. checked	Approved	Date	6/13/2017	<b>9829387700</b>		