

HAND DRYERS



ML_2400SAR_SS

Automatic Operation Nozzle Recessed Hand Dryer

Specification

Casing	1.2mm #304 Satin Stainless Steel
Facia Panel	2.0mm #304 Satin Stainless Steel
Nozzle	Chrome Plated Zinc
Motor	200W Brush Type: Dual Ball Bearings, 5500RPM 105°C auto reset safety overload
Power Use	240V, 50Hz, 2000-2400W, 10.0A
Sound Level	73db (+/- 3)
Drying Time	Less than 30 seconds
DP Rating	IPX 1
Element	1800-2200W
Heater	65°C auto reset thermostat
Warm Air	Speed: 28m/s Temp: Ambient +30°C
Protection	Over Heating Fuse (replaceable)
Timing	60 sec power cut off, auto reset
Sensor/Range	Auto Infrared - 180mm +/- 20mm preset, 100 - 300mm adjust
Case Security	4 SS theft resistant hex drive screws (hex key supplied)
Net Weight	9kg
Unit Size	320mmW x 338mmH x 178mmD
Wall Opening	295mmW x 313mmH x 175mmD
Nozzle	80mm projection
Warranty	1 year
Note	* This unit is accessible compliant when installed in accordance with AS1428.1. guidelines.

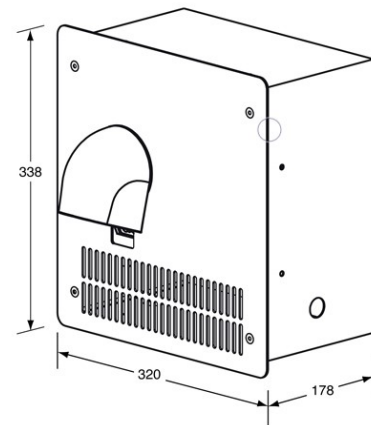

RoHS WEEE

Downloads & Resources

Care & Maintenance

The photographs and line drawings of the products presented above are representational only. Metlam Australia Pty Ltd reserves the right to, and from time to time, make changes and improvements in design and dimensions.