



Static Oven Range

Models:

CR6 (600mm)

CR9 (900mm)

INSTALLATION AND OPERATION MANUAL

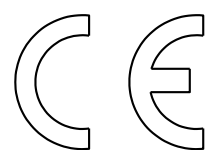

For use in GB & IE

MANUFACTURED BY

Moffat Limited

Christchurch
New Zealand

INTERNATIONAL CONTACTS

AUSTRALIA

Moffat Pty Limited

E.Mail: vsales@moffat.com.au
Main Office: (tel): +61 (03) 9518 3888
(fax): +61 (03) 9518 3833
Service: (tel): 1800 622 216
Spares: (tel): 1800 337 963
Customer Service: (tel): 1800 335 315
(fax): 1800 350 281

CANADA

Serve Canada

Web: www.servecanada.com
E.Mail: info@servecanada.com
Sales: (tel): 800 551 8795 (Toll Free)
Service: (tel): 800 263 1455 (Toll Free)

NEW ZEALAND

Moffat Limited

Web: www.moffat.co.nz
E.Mail: sales@moffat.co.nz
Main Office: (tel): 0800 663328

UNITED KINGDOM

Blue Seal

Web: www.blue-seal.co.uk
E.Mail: sales@blue-seal.co.uk
Sales: (tel): +44 121 327 5575
(fax): +44 121 327 9711
Spares: (tel): +44 121 322 6640
(fax): +44 121 327 9201
Service: (tel): +44 121 322 6644
(fax): +44 121 327 6257

UNITED STATES

Moffat

Web: www.moffat.com
Sales: (tel): 800 551 8795 (Toll Free)
(tel): +1 336 661 1556
(fax): +1 336 661 9546
Service: (tel): 800 858 4477 (Toll Free)
(tel): +1 366 661 1556
(fax): +1 336 661 1660

REST OF WORLD

Moffat Limited

Web: www.moffat.co.nz
E.Mail: export@moffat.co.nz

The reproduction or copying of any part of this manual by any means whatsoever is strictly forbidden unless authorized previously in writing by the manufacturer.

In line with policy to continually develop and improve its products, Moffat Ltd. reserves the right to change the specifications and design without prior notice.

© Copyright Moffat Ltd. April 2014.

Contents

CR6 Gas Static Oven Ranges (600mm Wide).

CR9 Gas Static Oven Ranges (900mm Wide).

Part 1	Introduction	2
Part 2	Specifications	3
Part 3	Installation.....	6
Part 4	Operation.....	9
Part 5	Cleaning and Maintenance.....	12
Part 6	Gas Conversion.....	15
Part 7	Replacement Parts List.....	22

Part 1 Introduction

We are confident that you will be delighted with your **Cobra Series** Ranges, and it will become a most valued appliance in your commercial kitchen.

To ensure you receive the utmost benefit from your new **Cobra Series** Appliance, there are two important things you can do.

Firstly:

Please read this instruction book carefully and follow the directions given. The time taken will be well spent.

Secondly:

If you are unsure of any aspect of the installation, instructions or performance of your appliance, contact your **Cobra Series** Range dealer promptly. In many cases a phone call could answer your question.

CE Only:

These instructions are only valid if the country code appears on the appliance. If the code does not appear on the appliance, refer to the supplier of this appliance to obtain the technical instructions for adapting the appliance to the conditions for use in that country.

WARNING:

IMPROPER INSTALLATION, ADJUSTMENT, ALTERATION, SERVICE OR MAINTENANCE CAN CAUSE PROPERTY DAMAGE, INJURY OR DEATH. READ THE INSTALLATION, OPERATING AND MAINTENANCE INSTRUCTIONS THOROUGHLY BEFORE INSTALLING OR SERVICING THIS APPLIANCE.

WARNING:

INSTRUCTIONS TO BE FOLLOWED IN THE EVENT THE USER SMELLS GAS ARE TO BE POSTED IN A PROMINENT LOCATION. THIS INFORMATION SHALL BE OBTAINED BY CONSULTING THE LOCAL GAS SUPPLIER.

WARNING:

GREAT CARE MUST BE TAKEN BY THE OPERATOR TO USE THE EQUIPMENT SAFELY TO GUARD IT AGAINST RISK OF FIRE.

- **THE APPLIANCE MUST NOT BE LEFT ON UNATTENDED.**
- **IT IS RECOMMENDED THAT A REGULAR INSPECTION IS MADE BY A COMPETENT SERVICEMAN TO ENSURE CORRECT AND SAFE OPERATION OF YOUR APPLIANCE IS MAINTAINED.**
- **DO NOT STORE OR USE GASOLINE OR OTHER FLAMMABLE VAPOURS OR LIQUIDS IN THE VICINITY OF THIS OR ANY OTHER APPLIANCE.**
- **DO NOT SPRAY AEROSOLS IN THE VICINITY OF THIS APPLIANCE WHILE IT IS IN OPERATION.**

CAUTION:

This appliance is;

- **For professional use and is to be used by qualified persons only.**
- **Only qualified service persons are to carry out installation, servicing and gas conversion operations.**
- **Components having adjustments protected (e.g. paint sealed) by the manufacturer should not be adjusted by the user / operator.**
- **DO NOT operate the appliance without the legs supplied fitted.**

Part 2 Specifications

Model Covered in this Specification -

CR6D [1]	Range	4 Open Burners.
CR6C [1]	Range	2 Burners + 300mm Griddle.
CR6B	Range	600mm Griddle.
CR9D [1]	Range	6 Open Burners.
CR9C [1]	Range	4 Burners + 300mm Griddle.
CR9B [1]	Range	2 Burners + 600mm Griddle.
CR9A	Range	900mm Griddle.

[1] - Open Burner Options;
 F - With Flame Failure Protection.
 - Standard Burners.

General

A heavy duty, general purpose gas range created for compact modular kitchens and available in a 600mm and 900mm wide option. It has a high option Cooktop / Griddle arrangement and is available on adjustable front feet and robust rear rollers. Open Burners have Flame Failure Option as standard for UK market and as an option for all other markets.

Griddles are available in 300mm, 600mm and for the CR9 Gas Static Oven Range, 900mm options and are fitted with pilot, flame failure and piezo ignition as standard.

The CR6 Oven is a 490mm (internal) full width oven fitted with French style opening doors. The oven burner is a 24-26 MJ oven burner and has pilot and flame failure with piezo ignition.

The CR9 Oven is a 780mm (internal) full width oven fitted with French style opening doors. The oven burner is a 28-30 MJ oven burner and has pilot and flame failure with piezo ignition.

The Range has an easy clean stainless steel external finish.

Gas Supply Requirements

- Australia:

	Natural Gas				LP Gas (Propane)			
	Open Burner (each)	Griddle (each 300mm section)	Oven		Open Burner (each)	Griddle (each 300mm section)	Oven	
			CR6	CR9			CR6	CR9
Input Rate (N.H.G.C.)	22 MJ/hr	20 MJ/hr	24 MJ/hr	28 MJ/hr	22 MJ/hr	20 MJ/hr	24 MJ/hr	28 MJ/hr
Supply Pressure	1.13 - 3.40 kPa				2.75 - 4.50 kPa			
Burner Operating Pressure (*)	1.0 kPa (*)				2.6 kPa (*)			
Gas Connection	¾" BSP Male							

- New Zealand:

	Natural Gas				LP Gas			
	Open Burner (each)	Griddle (each 300mm section)	Oven		Open Burner (each)	Griddle (each 300mm section)	Oven	
			CR6	CR9			CR6	CR9
Input Rate (N.H.G.C.)	22 MJ/hr	20 MJ/hr	24 MJ/hr	28 MJ/hr	22 MJ/hr	20 MJ/hr	24 MJ/hr	28 MJ/hr
Supply Pressure	1.13 - 3.40 kPa				2.75 - 4.50 kPa			
Burner Operating Pressure (*)	1.0 kPa (*)				2.6 kPa (*)			
Gas Connection	¾" BSP Male							

NOTE:

(*) Measure burner operating pressure at manifold test point with two burners operating at full setting. Operating pressure is ex-factory set, through the appliance regulator and is not to be adjusted, apart from when carrying out gas conversion, if required. (Refer to 'Gas Conversion' Section for further details).

Part 2 Specifications

- United Kingdom:

		Natural Gas (G20)				Propane (G31)			
		Open Burner (each)	Griddle (each 300mm section)	Oven		Open Burner (each)	Griddle (each 300mm section)	Oven	
				CR6	CR9			CR6	CR9
Heat Input (nett)	Nominal	5.0 kW	5.0 kW	6.5 kW	7.5 kW	4.6 kW	5.0 kW	6.0 kW	7.5 kW
	Reduced	1.7 kW	1.5 kW	1.1 kW	2.2 kW	1.5 kW	2.2 kW	1.05 kW	2.3 kW
Gas Rate (nett)	Nominal	0.53 m ³ /hr	0.53 m ³ /hr	0.51 m ³ /hr	0.79 m ³ /hr	0.36 kg/hr	0.39 kg/hr	0.47 kg/hr	0.58 kg/hr
	Reduced	0.18 m ³ /hr	0.16 m ³ /hr	0.14 m ³ /hr	0.23 m ³ /hr	0.12 kg/hr	0.17 kg/hr	0.09 kg/hr	0.18 kg/hr
Supply Pressure		20 mbar				37 mbar			
Operating Pressure (*)		10 mbar (*)				28 mbar (*)			
Gas Connection		3/4" B.S.P. Male							

NOTE:

(*) Measure burner operating pressure at manifold test point with two burners operating at full setting. Operating pressure is ex-factory set, through the appliance regulator and is not to be adjusted, apart from when carrying out gas conversion, if required. (Refer to 'Gas Conversion' Section for further details).

- All Other Markets:

		Natural Gas	Town Gas (**)
Input Rate (N.H.G.C.) - each Open Burner		22 MJ/hr	22 MJ/hr
- each 300mm Griddle Section		20 MJ/hr	20 MJ/hr
- Static Ovens	CR6	24 MJ/hr	24 MJ/hr
	CR9	28 MJ/hr	28 MJ/hr
Supply Pressure		1.13 - 3.40 kPa	0.75 - 1.50 kPa
Burner Operating Pressure (*)		1.0 kPa	0.63 kPa
Gas Connection		3/4" BSP Male	

		LP Gas (Propane)	LP Gas / Butane
Input Rate (N.H.G.C.) - each Open Burner		22 MJ/hr	22 MJ/hr
- each 300mm Griddle Section		20 MJ/hr	20 MJ/hr
- Static Ovens	CR6	24 MJ/hr	24 MJ/hr
	CR9	28 MJ/hr	28 MJ/hr
Supply Pressure		2.75 - 4.50 kPa	2.75 - 4.50 kPa
Burner Operating Pressure (*)		2.6 kPa	2.6 kPa
Gas Connection		3/4" BSP Male	

NOTE:

- Measure burner operating pressure at manifold test point with two burners operating at 'High Flame' setting.
- NAT, LPG & Butane Only - Operating pressure is ex-factory set and is not to be adjusted, apart from when converting between gasses, if required.
- TOWN GAS Only - Burner operating pressure is to be adjusted using the adjustable gas regulator supplied.
- Refer to 'Gas Conversion and Specifications' section in this manual for further details.

Gas Connection

CR6 Model

Gas supply connection point is located at the rear of the appliance, approximately 130mm from the right hand side, 45mm from the rear and 655mm from the floor and is reached from beneath the appliance. (Refer to the 'Dimensions' below).

For all Appliance Options, gas connection is 3/4" BSP male.

CR9 Model

Gas supply connection point is located at the rear of the appliance, approximately 130mm from the right hand side, 20mm from the rear and 655mm from the floor and is reached from beneath the appliance. (Refer to the 'Dimensions' below).

For all Appliance Options, gas connection is 3/4" BSP male.

Dimensions

CR6 Model

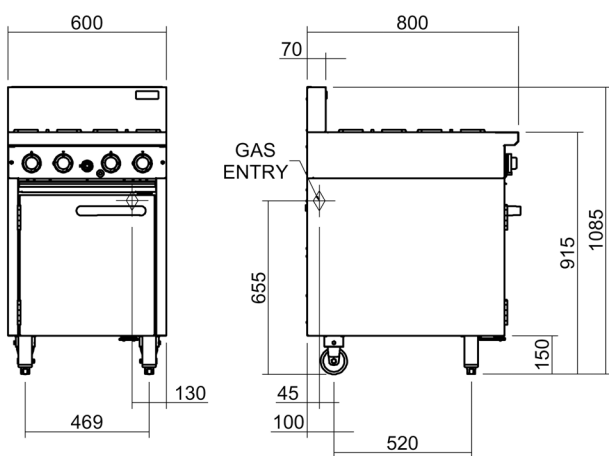

CR9 Model

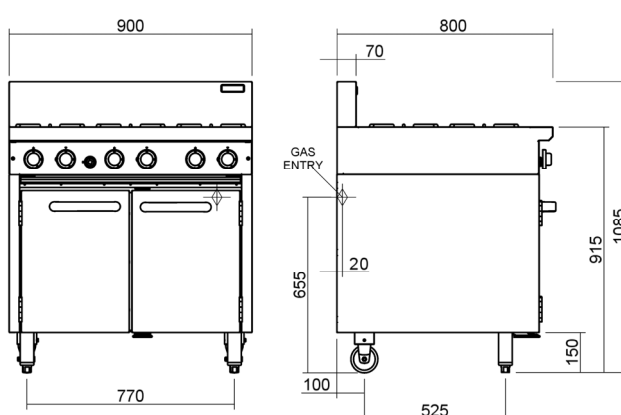

- Cooktop Model Options

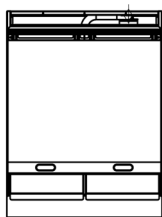

CR6B Model

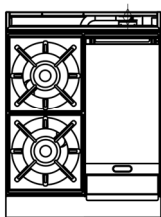

CR6C Model

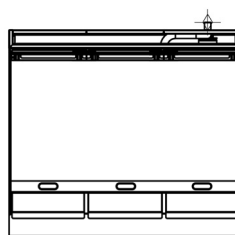

CR9A Model

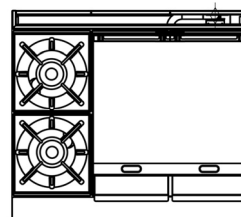

CR9B Model

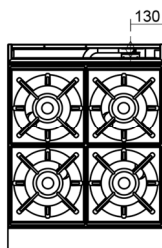

CR6D Model

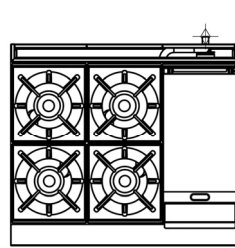

CR9C Model

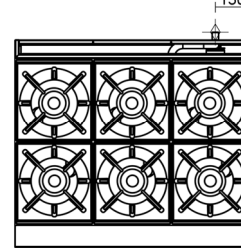

CR9D Model

Installation Requirements

NOTE:

It is most important that this appliance is installed correctly and that operation is correct before use. Installation shall comply with local, gas and health and safety requirements.

This appliance shall be installed with sufficient ventilation to prevent the occurrence of unacceptable concentrations of health harmful substances in the room that the appliance is installed in.

Cobra Series Ranges are designed to provide years of satisfactory service and correct installation is essential to achieve the best performance, efficiency and trouble-free operation.

This appliance must be installed in accordance with National installation codes and in addition, in accordance with relevant National / Local codes covering gas and fire safety.

Australia:

AS 5601- Gas Installations.

New Zealand:

NZS 5261- Gas Installation.

United Kingdom:

Gas Safety (Installation and Use) Regulations 1998.

BS6173 - Installation of Catering Appliances.

BS5440 1 & 2 - Installation Flueing & Ventilation.

Ireland:

IS 820 - Non Domestic Gas Installations.

Installations must be carried out by qualified service persons only. Failure to install equipment to the relevant codes and manufacturer's specifications shown in this section will void the warranty.

Components having adjustments protected (e.g. paint sealed) by manufacturer, are only to be adjusted by a qualified service agent. They are not to be adjusted by the installation person.

Unpacking

- Remove all packaging and transit protection from the appliance including all protective plastic coating from the exterior stainless steel panels.
- Check equipment and parts for damage. Report any damage immediately to the carrier and distributor.
- Report any deficiencies to the distributor who supplied the appliance.
- Check that the available gas supply is correct to that shown on the rating plate located on the front lower corner of the R/H side panel.

Location

1. This appliance must be installed in a suitably ventilated room to prevent dangerous build up of combustion products.
2. Installation must allow for a sufficient flow of fresh air for the combustion air supply.

Combustion Air Requirements

Natural Gas	41 m³/hr minimum.
LPG / Propane	43 m³/hr minimum.

3. Never directly connect a ventilation system to the appliance flue outlet.
4. Position the appliance in its approximate working position.
5. All air for burner combustion is supplied from underneath the appliance. The legs must always be fitted and no obstructions placed on the underside or around the base of the appliance, as obstructions will cause incorrect operation and / or failure of the appliance.
6. Components having adjustments protected (e.g. paint sealed) by manufacturer are only allowed to be adjusted by a qualified service agent. They are not to be adjusted by the installation person.

NOTE:

Do not obstruct or block the appliances flue. Never directly connect a ventilation system to the appliance flue outlet.

Clearances

NOTE:

Only non-combustible materials can be used in close proximity to this appliance.

Any gas burning appliance requires adequate clearance and ventilation for optimum and trouble free operation. The following minimum installation clearances are to be adhered to:

	Combustible Surface	Non Combustible Surface
LH / RH Side	250mm (*)	0mm
Rear	100mm	0mm

* Side clearances can be 50mm when the adjacent surface is at least 100mm below the cooking surface.

Assembly

This model is delivered completely assembled. Ensure that legs and rollers are securely attached.

NOTE:

This appliance is fitted with adjustable feet to enable the appliance to be positioned securely and level. This should be carried out on completion of the gas connection. Refer to the 'Gas Connection' section.

Gas Connection

NOTE:

ALL GAS FITTING MUST ONLY BE CARRIED OUT BY A QUALIFIED SERVICE PERSON.

1. Cobra Oven Ranges do not require an electrical connection, they function totally on the gas supply only.
2. It is essential that the gas supply is correct for the appliance to be installed and that adequate supply pressure and volume are available. The following checks should therefore be made before installation:-
 - a. **The Gas Type** the appliance has been supplied for is shown on coloured stickers located above the gas entry point and next to the rating plate. Check that this is correct for the gas supply the appliance is being installed for. The gas conversion procedure is detailed in the Gas Conversion Instruction Sheet for this appliance.
 - b. **Supply Pressure** required for this appliance is shown in the 'Specifications' section of this manual. Check the gas supply to ensure that adequate supply pressure exists.
 - c. **Input Rate** of this appliance is also stated on the Rating Plate rating plate located on the front lower corner of the R/H side panel, and in the 'Specifications' section of this manual. The input rate should be checked against the available gas supply line capacity. **Particular note should be taken if the appliance is being added to an existing installation.**

NOTE:

It is important that adequately sized piping runs directly to the connection joint on the appliance, with as few tees and elbows as possible to give maximum supply volume.

3. Fit the gas regulator supplied, into the gas supply line as close to the appliance as possible.

NOTE:

Gas pressure regulator provided with this appliance is convertible between Natural Gas and LPG as per the 'Gas Conversion Section' in this manual. Ensure the regulator is converted to the correct gas type that the appliance will operate on.

Regulator outlet pressure is fixed ex-factory for the gas type that the regulator is converted to and it is NOT to be adjusted.

The regulator connections are 3/4" BSP female.

The connection to the appliance is 3/4" BSP male.

(Refer to the 'Specifications' Section for the gas supply location dimensions).

NOTE:

A Manual Isolation Valve must be fitted to the individual appliance supply line.

4. Correctly locate the appliance into its final operating position and using a spirit level, adjust the legs so that the appliance is level and at the correct height.
5. Connect the gas supply to the appliance. A suitable joining compound which resists the breakdown action of LPG must be used on every gas line connection, unless compression fittings are used.
6. Check all gas connections for leakages using soapy water or other gas detecting equipment.

WARNING:

DO NOT USE A NAKED FLAME TO CHECK FOR GAS LEAKAGES.

7. Check that the gas supply pressure is as shown in the 'Specifications' section, 'Gas Supply Requirements'.

NOTE:

The supply pressure to be measured at the manifold test point and with 2 burners operating at the 'High Flame' setting.

8. Light the Main Burners. Refer to the 'Operations' Section', 'Open Burners'.
9. Verify that the supply pressure is still correct.
10. Check that the Main Burner is alight and adjust the low fire adjustment screw on the open burner gas control valves to obtain the desired flame size.
11. Check / adjust the main burner aeration gap. This gap should be set to the dimensions shown in the 'Gas Specification Tables' in 'Part 6 - Gas Conversion'.

NOTE:

This appliance is fitted with adjustable feet to enable the appliance to be positioned securely and level. This should be carried out on completion of the gas connection.

Commissioning

The following commissioning checks must be carried out before the Range is handed over for use, to ensure that the unit operates correctly and the operator(s) understand the correct operating procedure.

1. Before leaving the new installation;
 - a. Check the following functions in accordance with the operating instructions specified in the 'Operation' section of this manual.
 - Lighting the Griddle.
 - Lighting the Open Burners.
 - Lighting the Open Burners. (F - Flame Failure Option).
 - Check the Low Fire Burner Operation.
 - Light the Oven Pilot and Main Burners.
 - Check the Oven Main Burner Thermostat operation.
 - Turning the Oven to 'Stand-By' Mode.
 - Oven 'Shut Down'.
 - b. Ensure that each operator has been instructed in the areas of correct lighting, operation, and shutdown procedure for the appliance.
2. This manual must be kept by the owner for future reference and a record of the **Date of Purchase**, **Date of Installation** and **Serial Number of the Appliance** recorded and kept with this manual. (These details can be found on the Rating Plate rating plate located on the front lower corner of the R/H side panel.

NOTE:

If for some reason it is not possible to get the appliance to operate correctly, shut off the gas supply and contact the supplier of this unit.

Operation Guide

CAUTION:

- This appliance is for professional use and is only to be used by qualified persons.
- Only qualified service persons are to carry out installation, servicing or gas conversion operations.
- Components having adjustments protected (e.g. paint sealed) by the manufacturer should not be adjusted by the user / operator.

1. Cobra appliances have been designed to provide simplicity of operation and 100% safety protection.

2. Improper operation is therefore almost impossible, however bad operation practices can reduce the life of the appliance and produce a poor quality product. To use this appliance correctly please read the following sections carefully:-

- Lighting the Open Burners.
- Lighting the Open Burners. (F - Flame Failure Option).
- Lighting the Griddle.
- Oven Pilot Ignition.
- Oven Main Burner Thermostat.
- Turning the Oven to 'Stand-By' Mode.
- Oven 'Shut Down'.

Description of Controls

(CR9-Gas Range 900mm shown)

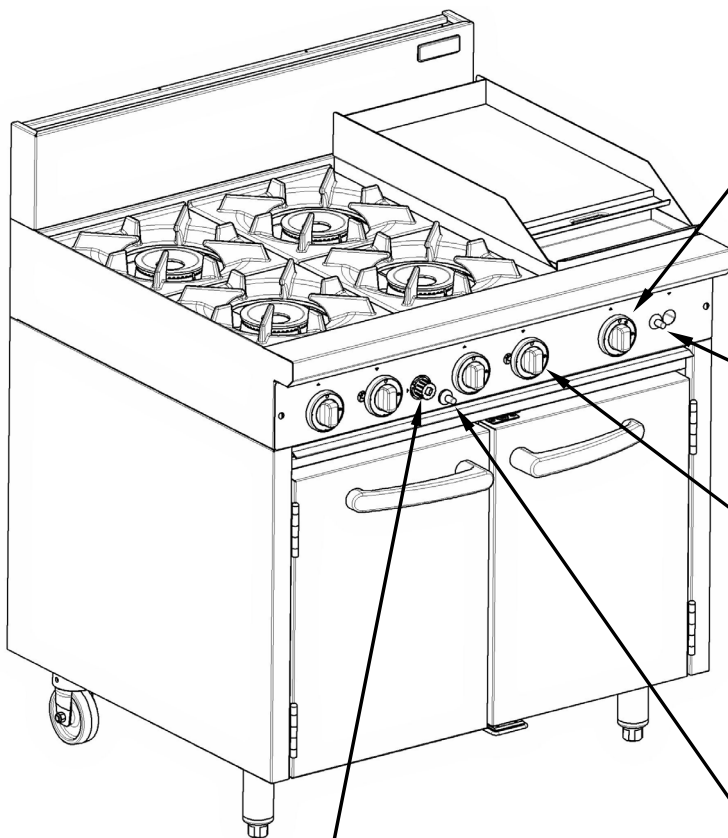

Gas Control Knobs

Griddle.

- OFF Position
- ★ PILOT Burner
- △ HIGH Flame
- △ LOW Flame

Piezo Igniter (Griddles Only)

Open Burners

- OFF Position
- △ HIGH Flame
- △ LOW Flame

▲ Rear Burner

▼ Front Burner

(Indicators located above the Gas Control Knobs).

Oven Control

- OFF Position
- ★ PILOT Burner

1-7 Thermostat Settings.

Piezo Igniter (Ovens Only)

Open Burners

NOTE:

Only cooking pans from size Ø 150 mm to Ø 420 mm are suitable for use on these open burners.

Lighting the Open Burners

(Flame Failure Protection is incorporated as standard for the UK Market and optional for Non -UK Markets, for each burner by way of a thermo-electric system which will shut off the gas supply to that burner in the event that the burner goes out, so that un-burnt gas is not expelled).

- Select the burner required, depress and turn the corresponding gas control knob anti-clockwise to the 'HIGH' position.
- With the gas control knob depressed, manually light the burner.
- Release the gas control knob after approximately 10-20 seconds after lighting the burner.
- The burner should stay alight - if not, repeat Steps (a to (c above).
- To achieve simmer control, depress the gas control knob and rotate between the 'HIGH' and 'LOW' positions to achieve the temperature required.

Turning 'OFF' the Open Burners

- When the main burner is not required, depress and turn the gas control knob clockwise back to the 'OFF' position. The 'MAIN' burner will extinguish.

Griddle

These griddles are fitted with Pilot and Flame Failure Protection as a standard option, which is incorporated by way of a thermo-electric system for each main burner. Flame Failure Protection will shut off the gas supply to that burner in the event that the pilot for that burner goes out, so that un-burnt gas is not expelled. **This is an important safety feature which is slowly becoming law throughout the world.**

CAUTION:

The griddle plate temperature reaches over 300°C in hottest points during normal operation at 'Full Flame' setting.

Lighting the Griddle

- Depress the gas control knob and rotate anti-clockwise to the 'PILOT' position.
- With the gas control knob depressed, press the piezo ignition button to ignite the pilot burner. Repeat Items 1 to 2 until the pilot is lit.
- Release the gas control knob approximately 10 to 20 seconds after lighting the pilot.

- The pilot should now remain alight - if not, repeat Steps (a. to (c. above).
- 'Full Flame' can now be achieved by depressing and rotating the gas control knob anti-clockwise to the first stop.
- Low flame can be achieved by depressing the gas control knob and rotating fully anti-clockwise to the 'Low Flame' position.
- When the main burner is not required, depress and turn the gas control knob clockwise back to the 'PILOT' position. The griddle burner will extinguish and the pilot will remain alight.

Turning 'OFF' the Griddle Burner / Pilot

- To turn 'OFF' the 'PILOT', depress and turn the gas control knob clockwise back to the 'OFF' position. The 'PILOT' burner will extinguish.

Oven

- Pilot Burner Ignition

WARNING:

HEAT EXPOSURE DANGER EXISTS WHEN OPENING THE OVEN DOOR WHILE THE OVEN IS STILL HOT.

This oven is fitted with a pilot as standard option and flame failure protection, which is incorporated by way of a thermo-electric system for the main burner. Flame failure protection will shut off the gas supply to the burner in the event that the pilot burner goes out, so that un-burnt gas is not expelled. **This is an important safety feature which is slowly becoming law throughout the world.**

! IMPORTANT

DO NOT USE aluminium foil or trays directly on the oven tray or flame baffle. NEVER block or cover the openings on each side of the flame baffle.

- Depress and rotate the thermostat control knob anti-clockwise to the 'PILOT' position.
- While holding the thermostat control knob depressed, press the piezo ignitor button to light the oven pilot burner. If required, repeat Items 1 to 2 until the oven pilot burner is lit.
- View the oven pilot burner through the hole in the front lower sill, with the oven door open.
- Release the thermostat control knob approximately 10-20 seconds after lighting the pilot burner.
- The pilot burner should now remain alight - if not, repeat Steps 2 to 4 above.

- Main Burner / Thermostat

1. With the pilot burner alight, rotate the oven thermostat control knob to the desired oven temperature setting, this will regulate the gas supply to the oven burner and the oven main burner will light from the pilot burner.
2. To turn the main burner 'OFF', simply turn the thermostat control knob to the 'OFF' position.
3. The oven thermostat control knob is marked 1 to 7.
4. The thermostat can be set anywhere within this range and will thermostatically maintain oven temperature.
5. The following chart indicates approximate oven centre temperatures that will be maintained at the knob markings.

Gas Mark Temperature Conversions

NOTE:

Approximate guide information only.

GAS MARK

1	2	3	4	5	6	7
100	130	160	190	225	260	290

TEMPERATURE °C

6. Temperatures required between the above should be obtained by setting the control between the markings.

Turning the Oven to 'Standby' (Pilot 'ON' Only)

1. To turn 'OFF' the oven main burner / heating, set the oven thermostat control knob to the 'PILOT' position, this will turn the oven 'OFF', but leave the oven pilot burner 'ON'.
2. In this position the pilot burner will remain alight, but the main burner will not operate until the oven thermostat control knob is set to a temperature.

Oven 'Shut-Down'

To 'Shut Down' the oven, turn the oven thermostat control knob to the 'OFF' position. This will turn 'OFF' the oven and extinguish the pilot burner. To relight the pilot burner, refer to 'Pilot Burner Ignition' in this section.

IMPORTANT

Should any abnormal operation like;

- ignition problems,
- abnormal burner flame,
- burner control problems,
- partial or full loss of burner flame in normal operation,

be noticed, the appliance requires IMMEDIATE service by a qualified service person and shall not be used until such service is carried out.

General

CAUTION:

Always turn off the gas supply at the mains supply before cleaning.

This appliance is not water proof. Do not use water jet spray to clean interior or exterior of this appliance.

General

Clean the Range regularly. A clean Range looks better, will last longer and will perform better. Carbonised grease on the surface or between the trivets, griddle plates will hinder the transfer of heat from the cooking surface to the food. This will result in loss of cooking efficiency.

NOTE:

NEVER use a ribbed scraper blade on the flat surfaced griddle plate.

DO NOT use water on the trivets, burners and griddle plates while these items are still hot as warping and cracking may occur. Allow these items to cool down and then remove for cleaning. The entire trivets, griddle plates and burner caps can be dismantled for cleaning.

NOTE:

- **DO NOT use abrasive detergents, strong solvents or caustic detergents as they could corrode or damage the Range.**
- **In order to prevent the forming of rust on the trivets, griddle plate (if fitted) and burners, ensure that any detergent or cleaning material has been completely removed after each cleaning. The appliance should be switched 'On' briefly to ensure that the griddle plates become dry. Oil or grease should be spread over the griddle surface in order to form a thin protective greasy film.**

To keep your Range clean and operating at peak efficiency, follow the procedures shown:-

After Each Use

CAUTION:

Always ensure that if using a flat scraper tool on the griddle surface, an even pressure is applied over the whole surface of the scraper tool to prevent scoring of the surface.

NEVER bang the sharp edge of the scraper tool on the flat surface of the griddle as this will damage the griddle and invalidate the warranty.

1. Clean the Griddle and Range castings using a scraper tool to remove any build up of carbon.

2. Always ensure that scraper tool blades are changed regularly to ensure that the scraper tool works efficiently and prevents damage to the griddle plate surface.
3. Clean the range castings with a stiff nylon brush or a flexible spatula to remove any food debris.

Daily Cleaning

1. The grease / spill tray(s) should be checked and emptied frequently to prevent overflow and spillage. Remove the spill tray(s) while still warm so that the grease is in a liquid state. Empty any grease from the trays and wash the trays thoroughly in the same manner as any cooking utensil.
2. Clean the control panel with a damp cloth lightly moistened with a solution of mild detergent and water. Wipe dry with a clean dry cloth.
3. Remove the burner caps, bases, the trivets and thoroughly clean including the splash back, interior and exterior surfaces of the range with hot water, a detergent solution and a soft scrubbing brush.
4. Brush the griddle surface (optional - if fitted) with a soft bristled brush. Any carbon deposits should be removed using a scraper tool followed by wiping with a cloth to prevent accumulation of food deposits.
5. Dry the Range thoroughly with a dry cloth and polish with a soft dry cloth.

Weekly Cleaning

NOTE:

- **If the Range usage is very high, we recommend that the weekly cleaning procedure is carried out on a more frequent basis.**
- **Ensure that protective gloves are worn during the cleaning process.**
- **DO NOT use harsh abrasive or caustic detergents or strong solvents as they will damage the cooktop, burners and griddle plates (if fitted).**
- **DO NOT use water on the trivets, griddle plates and burners while they are still hot as cracking may occur. Allow these items castings to cool and remove for cleaning.**
- **DO NOT clean the burners in a dishwasher.**

Range Cooking Area

- Clean the Range cooking area using a soft cloth moistened with a mild detergent and hot water solution.
- Baked on deposits or discolouration may require a good quality stainless steel cleaner or stainless steel wool. Always apply cleaner when the appliance is cold and rub in the direction of the grain.
- It should not be necessary to remove the splash guards covering the burner manifolds for cleaning purposes. These can be cleaned in situ.
- Remove the grease / spill tray(s) and clean with a mild anti bacterial detergent and hot water solution using a soft bristled brush. Dry the grease spill tray(s) thoroughly with a dry cloth.

Griddle Plate

CAUTION:

Always ensure that if using a flat scraper tool on the griddle surface, an even pressure is applied over the whole surface of the scraper tool to prevent scoring of the surface.

NEVER bang the sharp edge of the scraper tool on the flat surface of the griddle as this will damage the griddle and invalidate the warranty.

NOTE:

In order to prevent the forming of rust on the griddle plate, ensure that all detergent and cleaning material has been entirely removed after each cleaning process. The appliance should be switched on briefly to ensure that the griddle plate becomes dry. Oil or grease should be spread over the griddle surface in order to form a thin protective greasy film.

- Remove and clean the grease / spill tray(s) frequently to prevent over spills.
- Clean the griddle surface thoroughly with a scraper tool or a wire brush. If necessary use a griddle stone or a scotch bright pad on the griddle surface to remove stubborn or accumulated carbon deposits.
- A scraper tool can be used for the removal of stubborn carbon and deposits.
- Occasionally bleach the griddle plate with vinegar when the plate is cold.
- Clean with hot water, a mild detergent solution and a scrubbing brush. Dry all components thoroughly with a dry cloth.
- The Range should be switched on briefly to ensure that the griddle plate becomes dry. A thin smear of cooking oil should be spread over the grates in order to form a protective film.

Trivets and Burners

- Remove the trivets from the top of the appliance, taking note that the trivets are manufactured with a lip on one edge, the lip must always be fitted to the outer edge (front and back) of the Range.
- Remove the burner cap and burner complete with venturi tube, from the top of the range manifold, taking care not to damage the thermocouple (Fitted as standard for UK Market and optional for Non -UK Markets) fitted to the mounting rail.
- The trivets and burners should be cleaned with a mild detergent and hot water solution using a soft bristled brush. Dry thoroughly with a dry cloth.

Trivet Supports

- Remove all the trivet supports from the top of the range. Take note of the orientation of the trivet support when removing. The trivet support front side rail profiles are different from the rear side rail profiles.
- The trivet supports should be cleaned with a mild detergent and hot water solution using a soft bristled brush.
- Dry the trivet supports thoroughly with a dry cloth.

NOTE:

On units fitted with Flame Failure Thermocouples as standard or as an option, the Mounting Rail is Not removable for cleaning and no attempt should be made to remove this rail.

Stainless Steel Surfaces

- With the griddle plates and burners removed, clean the interior and exterior surfaces of the Range with hot water, a mild detergent solution and a soft scrubbing brush. Note that the gas control knobs are a push fit onto the gas control valve spindles and can be removed to allow cleaning of the front of the control panel.
- Baked on deposits or discolouration may require a good quality stainless steel cleaner or stainless steel wool. Always apply cleaner when the appliance is cold and rub in the direction of the grain.
- Dry all components thoroughly with a dry cloth and polish with a soft dry cloth.
- Remove the grease tray and clean with a mild anti bacterial detergent and hot water solution using a soft bristled brush.
- Dry the grease tray and all components thoroughly with a dry cloth and polish with a soft dry cloth.

Re-Fitting the Components to the Range

- a. Refit the trivet supports to the Range top, ensuring that the trivet supports are correctly fitted.

NOTE:

- **It is imperative that the trivet supports are correctly re-fitted to the appliance to ensure that the burners and trivets locate correctly and sit flush and level.**
 - **Note the orientation of the trivet supports when re-fitting. The trivet support front side rail profiles are different from the rear side rail profiles and will only fit one way to the cooktop.**
- b. Refit the burners and burner caps onto the Range cooktop.
 - c. Refit the trivets to the cook top, taking note that the trivets are manufactured with a lip on one edge, the lip must always be fitted to the outer edge (front and back) of the range.
 - d. Refit the spill / grease tray(s) to the range.

Oven Interior

- a. Do not use wire brushes, steel wool or other abrasive materials to clean the oven interior.
- b. Clean the oven regularly with a good quality domestic oven cleaner.
- c. Once a week, remove and clean any built up of grease etc. from the oven racks and the bottom spill over cover.
- d. Dry the oven thoroughly with a dry cloth and polish with a soft dry cloth.

Periodic Maintenance

NOTE:

All maintenance operations should only be carried out by a qualified service person.

To achieve the best results cleaning must be regular and thorough and all controls and mechanical parts should be checked and adjusted periodically by a qualified service person. If any small faults occur, have them attended to promptly. Don't wait until they cause a complete breakdown. It is recommended that the appliance is serviced every 6 months.

Gas Control Valve Re-Greasing

The gas control valve should be dismantled and greased every 6 months to ensure the correct operation of the gas control valve.

To carry out this operation;-

- a. Remove the gas control knobs from the gas tap spindles by pulling the knobs away from the control panel.
- b. Remove the drip tray from the appliance.
- c. Remove the two screws on the underside of the control panel, securing the control panel to the hob.
- d. Remove the control panel from the front of the appliance.
- e. Remove the 2 screws holding the shaft plate to the gas control body and remove the control shaft and plate. Note the orientation of shaft for correct re-assembly.

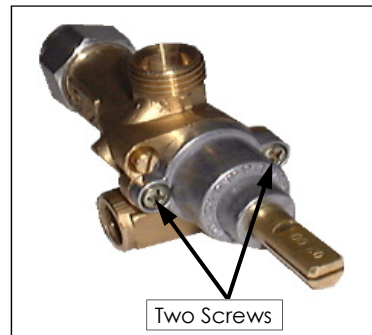

- f. Using needle nose pliers or similar, pull out the gas control spindle, again noting its orientation.

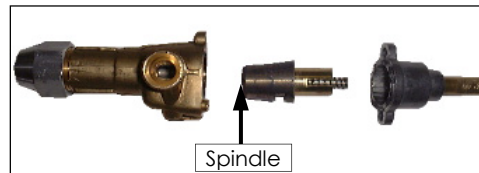

- g. Apply a suitable high temperature gas cock grease or lubricant such as ROCOL - A.S.P (Anti scuffing paste) / Dry Moly Paste to the outside of the spindle.
- h. Replace spindle and re-assemble the gas control valve in reverse order.
- i. Refit the control panel to the appliance and secure with the 2 screws.
- j. Refit the knobs to the gas control valve spindles.

Gas Conversion Procedure

CAUTION:

Ensure that the unit is isolated from the gas supply before commencing servicing.

NOTE:

- These conversions should only be carried out by qualified persons. All connections must be checked for leaks before re-commissioning the appliance.
- Adjustment of components that have adjustments / settings sealed (e.g. paint sealed) can only be adjusted in accordance with the following instructions and shall be re-sealed before re-commissioning this appliance.
- For all relevant gas specifications refer to the tables at the end of this section.

Open Burners

1. Remove pot stands, burner caps, burner bodies and pot stand supports.

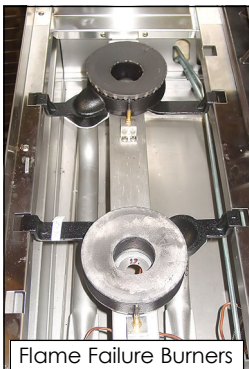

2. Remove injectors and replace with correct size injectors as shown in 'Gas Specifications Tables' at end of this section.
3. Refit pot stand supports, pot stands, burner caps and burner bodies.
4. Re-light main burners and check flame size on simmer (LOW) position.

Low Fire Adjustment

- Adjust low fire adjustment screw on open burner gas control valves to obtain desired flame size.

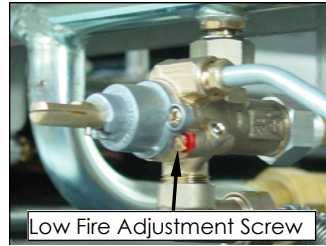

NOTE: The 'Low Fire Screw' should be sealed with coloured paint on completion of low fire adjustment.

Aeration Adjustment

1. Check / adjust main burner aeration gap. This gap should be set to the dimensions shown in the 'Gas Specification Tables' at the end of this section.

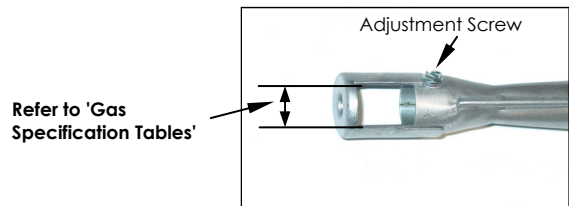

Thermocouple Location

1. Check that thermocouple is correctly located and that the gap between the thermocouple and main burner is as shown in the diagram below.

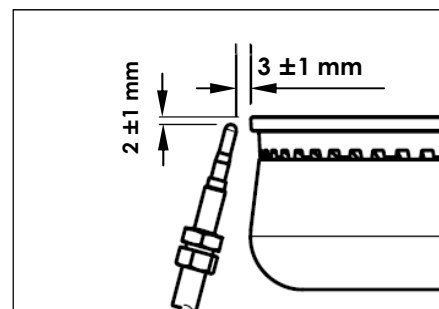

2. Check that the thermocouple to gas valve connection is tight.

Part 6 Gas Conversion

Griddle

- Carry out the following:-
 - Remove griddle plate section and heat shield.

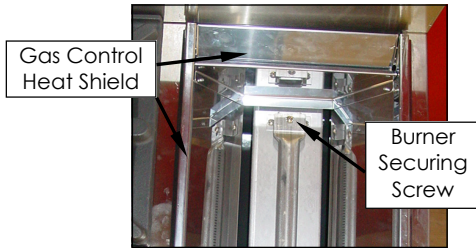

- Remove main burner.
- Disconnect piezo igniter from mounting bracket. (For access purposes).
- Disconnect pilot supply tube from pilot burner to access pilot injector.

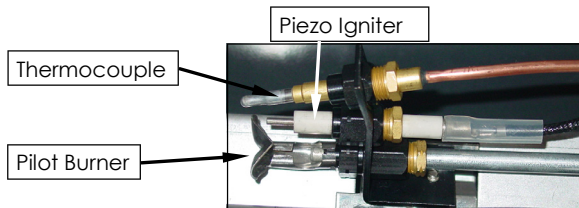

- With Main Burner removed, ensure aeration gap is adjusted for type of gas being used as shown in 'Gas Specifications Tables' at end of this section.

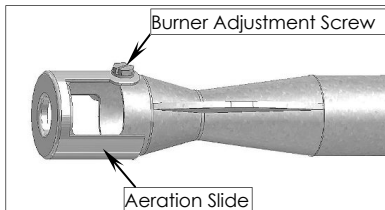

- Remove pilot and main injectors and replace with correct size injectors as shown in 'Gas Specifications Tables' at end of this section.
- Refit the following:-
 - Re-connect pilot supply tube to pilot burner.
 - Re-connect piezo igniter to mounting bracket.
 - Refit main burner, gas control heat shield and griddle plate to cooktop.
- Re-light main burners and check flame size on 'Low' flame position.
 - Adjust low fire adjustment screw on open burner gas control valves to obtain desired flame size.**

NOTE:
On completion of low fire adjustment 'Low Fire Screw' should be sealed with coloured paint.

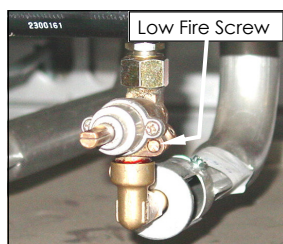

Oven

Main Burner

- Turn off gas supply at main supply.
- Remove oven racks, oven tray and flame baffle from inside oven.
- Remove the oven main burner.

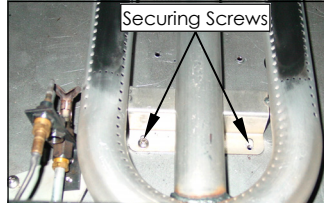

Main Burner - CR9 Model

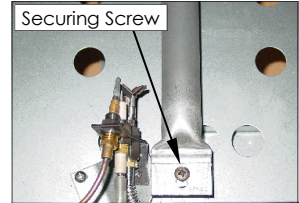

Main Burner - CR6 Model

- Remove main burner injector and replace with correct size injector. (Refer to 'Gas Specifications' table at rear of this section).

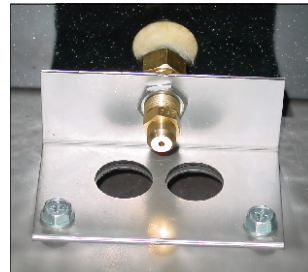

Main Burner Injector CR9

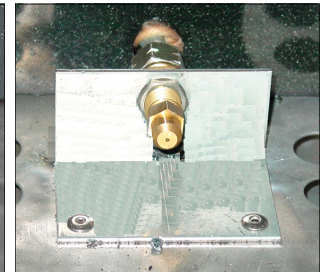

Main Burner Injector - CR6

- Refit the following:-
 - Main burner.

Pilot Burner

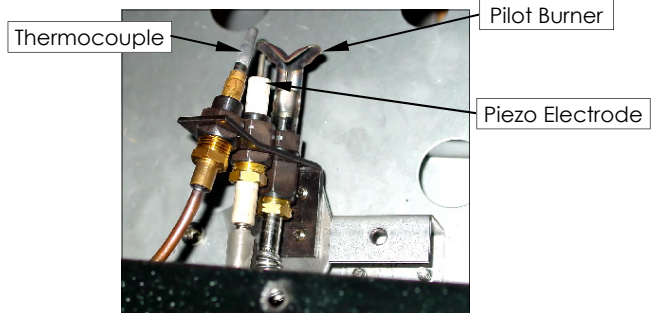

- Remove the following:-
 - Thermocouple (for access).
 - Piezo electrode (for access).
 - Unscrew pilot supply tube.
- Remove pilot injector and replace with correct size injector. (Refer to 'Gas Specifications' table at rear of this section).
- Refit the following:-
 - Thermocouple (removed for access).
 - Piezo electrode (removed for access).
 - Pilot supply tube.
 - Flame baffle.
 - Oven racks.
 - Oven trays.

Low Fire Adjustment

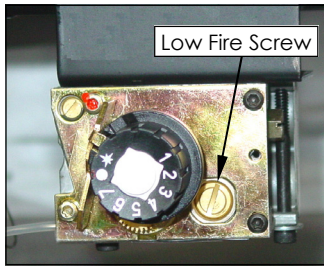

- To change the thermostat 'Low Fire' screw for the gas type required, remove the following:-
 - Gas control knobs.
 - Control Panel.
 - Unscrew 'Low Fire' screw from gasvalve.
 - and fully screw in the new 'Low Fire' screw for the new gas type. (Refer to the 'Gas Specifications' table at the rear of this section for the correct low fire screw sizes).
- Refit the control panel.
- Refit the gas control knobs.

Gas Regulator

- NAT Gas / LPG / Butane Only.

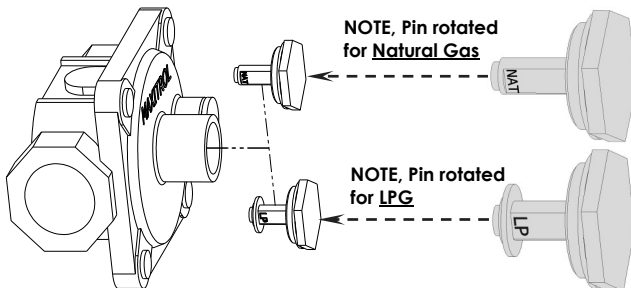

NOTE:

The regulator supplied is convertible between Natural Gas and LP Gas, but it's outlet pressure is fixed ex-factory and is NOT to be adjusted.

- Ensure that the gas supply is turned 'Off' at the mains.
- Unscrew the hexagonal cap (23mm A/F) from the regulator.
- Un-clip the plastic pin from the cap, reverse the pin and re-fit it back to the cap the correct way for the gas type to be used. **(Either 'LP' or 'NAT' should be visible on the flank of the pin once re-fitted to the cap).**
- Screw the cap back into the regulator hand tight only.

- Town Gas Only.

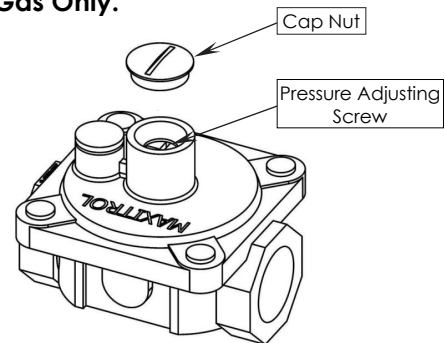

- Unscrew and remove slotted cap from regulator.
- Turn 'On' gas supply and appliance.
- Adjust pressure adjusting nut to achieve correct burner operating pressure.

NOTE:

Operating pressure is to be measured at the manifold test point and with both burners operating at 'High Flame' setting.

- Verify operating pressure remains correct (Re-adjust the regulator if required).
- Screw cap nut back onto regulator.

Gas Type Identification Label

On completion of gas conversion, replace gas type identification label located at:-

- Rear of appliance, above gas connection.
- Beside the rating plate.

Commissioning

Before leaving the converted installation;

- Check all gas connections for leakages using soapy water or other gas detecting equipment.

WARNING:

DO NOT USE A NAKED FLAME TO CHECK FOR GAS LEAKAGES.

- Check the following functions in accordance with operating instructions specified in the 'Operation' section of this manual.
 - Light Main Burners.
 - Check Low Fire burner operation.
 - Check High Fire burner operation.
 - Check Griddle Burner operation (If fitted).
 - Ensure that all controls operate correctly.
 - Ensure that operating pressure remains correct.
- Ensure any adjustments done to components that have adjustments / settings sealed (e.g. paint sealed), these are re-sealed.

NOTE:

If it is not possible to get the appliance to operate correctly, shut 'Off' the gas supply and contact the supplier of this appliance.

Part 6 Gas Conversion

Gas Specifications

- Australia

		Natural Gas	LP Gas (Propane)	
Open Burner	Burner Injector	Ø 2.10mm	Ø 1.30mm	
	Low Fire Setting	¼ turn open c.c.w.	¼ turn open c.c.w.	
	Burner Aeration Setting	16mm open.	16mm open.	
Griddle	Burner Injector	Ø 2.00mm	Ø 1.25mm	
	Low Fire Setting	5/8 turn open c.c.w.	3/8 turn open c.c.w.	
	Burner Aeration Setting	Fully open.	Fully open.	
	Pilot Injector	0.35	0.23	
Oven	CR6 Model	Burner Injector	Ø 2.40mm	Ø 1.40mm
		Low Fire Screw	Ø 1.00mm	Ø 0.60mm
		Burner Aeration Setting	Fully open.	10mm open.
		Pilot Injector	0.35	0.23
	CR9 Model	Burner Injector	Ø 2.50mm	Ø 1.50mm
		Low Fire Screw	Ø 1.50mm	Ø 0.95mm
		Burner Aeration Setting	Fully open.	Fully open.
		Pilot Injector	0.35	0.23
Supply Pressure		1.13 - 3.40 kPa	2.75 - 4.50 kPa	
Burner Operating Pressure (*)		1.0 kPa	2.6 kPa	
Gas Regulator Cap Screw				

- New Zealand

		Natural Gas	LP Gas (Propane)	
Open Burner	Burner Injector	Ø 2.10mm	Ø 1.30mm	
	Low Fire Setting	¼ turn open c.c.w.	¼ turn open c.c.w.	
	Burner Aeration Setting	16mm open.	16mm open.	
Griddle	Burner Injector	Ø 2.00mm	Ø 1.25mm	
	Low Fire Setting	5/8 turn open c.c.w.	3/8 turn open c.c.w.	
	Burner Aeration Setting	Fully open.	Fully open.	
	Pilot Injector	0.35	0.23	
Oven	CR6 Model	Burner Injector	Ø 2.40mm	Ø 1.40mm
		Low Fire Screw	Ø 1.00mm	Ø 0.60mm
		Burner Aeration Setting	Fully open.	10mm open.
		Pilot Injector	0.35	0.23
	CR9 Model	Burner Injector	Ø 2.50mm	Ø 1.50mm
		Low Fire Screw	Ø 1.50mm	Ø 0.95mm
		Burner Aeration Setting	Fully open.	Fully open.
		Pilot Injector	0.35	0.23
Supply Pressure		1.13 - 3.40 kPa	2.75 - 4.50 kPa	
Burner Operating Pressure (*)		1.0 kPa	2.6 kPa	
Gas Regulator Cap Screw				



NOTE:

- * Measure burner operating pressure at manifold test point with two burners operating at 'High' setting. Operating pressure is ex-factory set, through the appliance regulator and is not to be adjusted, apart from when carrying out gas conversion, if required. (Refer to the information in this section for details).

Part 6 Gas Conversion

- United Kingdom

Category: **II_{2H3P}**
 Flue Type: **A₁**

		Natural Gas (G20)	Propane (G31)	
Open Burner	Burner Injector	Ø 1.90mm	Ø 1.20mm	
	Low Fire Setting	¾ turn open c.c.w.	¼ turn open c.c.w.	
	Burner Aeration Setting	16mm open.	16mm open.	
Griddle	Burner Injector	Ø 2.00mm	Ø 1.25mm	
	Low Fire Setting	5/8 turn open c.c.w.	3/8 turn open c.c.w.	
	Burner Aeration Setting	Fully open.	Fully open.	
	Pilot Injector	0.35	0.23	
Oven	CR6 Model	Burner Injector	Ø 2.40mm	Ø 1.40mm
		Low Fire Screw	Ø 1.00mm	Ø 0.60mm
		Burner Aeration Setting	Fully open.	10mm open.
		Pilot Injector	0.35	0.23
	CR9 Model	Burner Injector	Ø 2.50mm	Ø 1.50mm
		Low Fire Screw	Ø 1.50mm	Ø 0.95mm
		Burner Aeration Setting	Fully open.	Fully open.
		Pilot Injector	0.35	0.23
Supply Pressure		20 mbar	37 mbar	
Burner Operating Pressure (*)		10 mbar	28 mbar	
Gas Regulator Cap Screw				

NOTE:

- * Measure burner operating pressure at manifold test point with two burners operating at 'High' setting. Operating pressure is ex-factory set, through the appliance regulator and is not to be adjusted, apart from when carrying out gas conversion, if required. (Refer to the information in this section for details).

Part 6 Gas Conversion

- All Other Markets

		Natural Gas	Town Gas (**)	
Open Burner	Burner Injector	Ø 2.10mm	Ø 3.80mm	
	Low Fire Setting	¾ turn open c.c.w.	1 turn open c.c.w.	
	Burner Aeration Setting	16mm open.	16mm open.	
Griddle	Burner Injector	Ø 2.00mm	Ø 3.40mm	
	Low Fire Setting	5/8 turn open c.c.w.	1 turn open c.c.w.	
	Burner Aeration Setting	Fully open.	Fully open.	
	Pilot Injector	0.35	0.60	
Oven	CR6 Model	Burner Injector	Ø 2.40mm	Ø 4.50mm
		Low Fire Screw	Ø 1.00mm	Ø 1.50mm
		Burner Aeration Setting	Fully open.	Fully open.
		Pilot Injector	0.35	0.60
	CR9 Model	Burner Injector	Ø 2.50mm	Ø 5.00mm
		Low Fire Screw	Ø 1.50mm	Ø 2.50mm
		Burner Aeration Setting	Fully open.	Fully open.
		Pilot Injector	0.35	0.60
Supply Pressure		1.13 - 3.40 kPa	0.75 - 1.50 kPa	
Burner Operating Pressure (*)		1.0 kPa	0.63 kPa	
Gas Regulator Cap Screw			Adjustable Regulator (Adjust to 0.63 kPa Burner Operating Pressure).	

		LP Gas (Propane)	LP Gas / Butane	
Open Burner	Burner Injector	Ø 1.30mm	Ø 1.20mm	
	Low Fire Setting	¼ turn open c.c.w.		
	Burner Aeration Setting	16mm open.	Fully open.	
Griddle	Burner Injector	Ø 1.25mm	Ø 1.20mm	
	Low Fire Setting	3/8 turn open c.c.w.		
	Burner Aeration Setting	Fully open.		
	Pilot Injector	0.23		
Oven	CR6 Model	Burner Injector	Ø 1.40mm	Ø 1.30mm
		Low Fire Screw	Ø 0.60mm	
		Burner Aeration Setting	10mm open.	
		Pilot Injector	0.23	
	CR9 Model	Burner Injector	Ø 1.50mm	Ø 1.40mm
		Low Fire Screw	Ø 0.95mm	
		Burner Aeration Setting	Fully open.	
		Pilot Injector	0.23	
Supply Pressure		2.75 - 4.50 kPa		
Burner Operating Pressure (*)		2.6 kPa		
Gas Regulator Cap Screw				

NOTE:

- (*) Measure burner operating pressure at manifold test point with two burners operating at 'High Flame' setting.
- NAT, LPG & Butane Only - Operating pressure is ex-factory set and is not to be adjusted, apart from when converting between gases, if required.
- (**) TOWN GAS Only - Adjust burner operating pressure using the adjustable gas regulator supplied. Eurosit oven gas control valve requires non-adjustable Max Rate Screw to be fitted.
- Refer to the information in this section for further details.

Replacement Parts List

IMPORTANT:

Only genuine qualified replacement parts should be used for the servicing and repair of this appliance. The instructions supplied with the parts should be followed when replacing components.

For further information and servicing instructions, contact your nearest qualified service branch (contact details are as shown on the reverse of the front cover of this manual).

When ordering spare parts, please quote the part number and the description as listed below. If the part required is not listed below, request the part by description and quote model number and serial number which is shown on the rating plate.

Open Burners

230014	Pot Stand.		
230088	Pot Stand Support.		
230631	Front Burner Assy.		
230632	Rear Burner Assy.		
230288	Burner Cap.		
230637	Gasket Burner Assy.		
037210	Injector	(Nat. Gas)	Ø 2.10mm.
037130	Injector	(LP Gas)	Ø 1.30mm.
037120	Injector	(Butane)	Ø 1.20mm.
037380	Injector	(Town Gas)	Ø 3.80mm.
018680	Gas Control Pintossi 20N		(Standard Burners Only).
231560	Gas Control Pintossi 20S		(Flame Failure '-F' Models Only).
019428	Thermocouple - (320mm).		
230671	Thermocouple - (500mm).		
230606	Knob - Open Burner.		

Griddle

014105	Griddle Burner.		
230213	Griddle Reflector Assy.		
227403	Gas Control Valve.		
230608	Knob - Griddle.		
032200	Injector	(Nat. Gas)	Ø 2.00mm.
032125	Injector	(LP Gas)	Ø 1.25mm.
032120	Injector	(Butane)	Ø 1.20mm.
032340	Injector	(Town Gas)	Ø 3.40mm.
019215	Pilot Burner (Fully Assembled).		
026488	Pilot Injector	(Nat. Gas)	0.35.
019217	Pilot Injector	(LP Gas / Butane)	0.23.
018067	Pilot Injector	(Town Gas)	0.60.
019428	Thermocouple - (320mm).		
230586	Piezo Ignitor.		
228047	Piezo H.T. Lead.		
230289	Grease Tray	(1 per 300mm Griddle Section).	
230059	Griddle Plate	300mm.	
230084	Griddle Plate	600mm.	
230091	Griddle Plate	900mm.	
230091	Griddle Plate	900mm (CR9 Only).	

Part 7 Replacement Parts List

Oven

022446	Oven Burner (CR6).
230441	Oven Burner (CR9).
235493	Eurosit Gas Control Valve.
228836	Max Rate Screw (Town Gas).
018682	Thermocouple (1500mm Long).
230586	Piezo Igniter.
232691	HT Lead 1600mm.
230556	Oven Rack.
230462	Oven Tray.
011005	Ball Catch Assy.
230487	Top Striker Plate.
010254	Bottom Striker Plate.
227469	Door Handle.

CR6 Model

032240	Injector	(Nat. Gas)	Ø 2.40mm.
032140	Injector	(LP Gas [Propane])	Ø 1.40mm.
032130	Injector	(Butane)	Ø 1.30mm.
032450	Injector	(Town Gas)	Ø 4.50mm.
022409	Low Fire Screw	(Nat. Gas) Ø 1.00mm.	
234038	Low Fire Screw	(LP Gas / Butane) Ø 0.60mm.	
022408	Low Fire Screw	(Town Gas) Ø 1.50mm.	

CR9 Model

032250	Injector	(Nat. Gas)	Ø 2.50mm.
032150	Injector	(LP Gas)	Ø 1.50mm.
032140	Injector	(Butane)	Ø 1.40mm.
032500	Injector	(Town Gas)	Ø 5.00mm.
022408	Low Fire Screw	(Nat. Gas)	Ø 1.50mm.
022407	Low Fire Screw	(LP Gas / Butane)	Ø 0.95mm.
232312	Low Fire Screw	(Town Gas)	Ø 2.50mm.

CR6 / CR9 Models

026488	Pilot Injector	(Nat. Gas)	0.35.
019217	Pilot Injector	(LP Gas / Butane)	0.23.
018067	Pilot Injector	(Town Gas)	0.60.

General

230138	Drip Tray (CR6).
230139	Drip Tray (CR9).
229674	Rear Roller Assy.
234059	Leg Assy (150mm).

Gas Regulators

Gas Type	Gas Regulators	
	Part No.	Description
Nat. Gas LP Gas Butane	228531	¾" BSP F/F Convertible.
Town Gas	230185	¾" BSP F/F Adjustable.

Gas Conversion Kits

Model	Gas Type to Convert to:			
	LP Gas	Nat. Gas	Butane	Town Gas
CR6	234043	234042	234044	234045
CR9	231573	231572	231574	231577

