

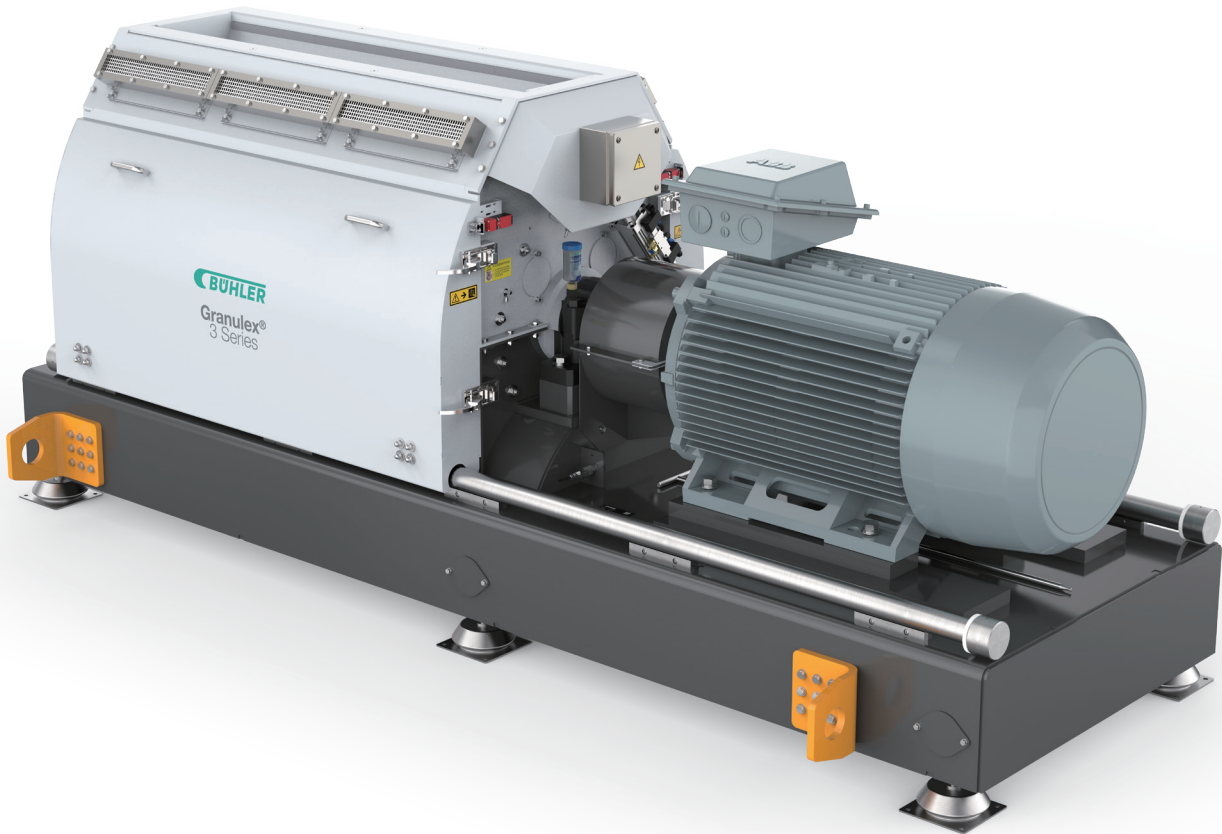

Granulex™ 3 Series Hammer Mill

Granulex™ 3 Series. Excellent grinding quality and throughputs.



Applications

Coarse grinding for feed and food applications and fine grinding for petfood and fish feed production.

Product features

- Large rotor diameter with optimized hammer tip speed ensures maximum material contact for efficient size reduction;
- Stationary hammer structure (AHZC66100 and above) can break the circulation layer effectively, which improves the efficiency of the mill;
- Multi grinding chamber structure, screen combination is more flexible;
- The clockwise and counterclockwise operation mode guarantees uniform wear of the hammers and screens.

Mode of operation

The feeder is mounted on top of the hammer mill to obtain a uniform feed rate. It also functions as an iron separator. The mill offers excellent access for screen and hammer changes through two large maintenance doors. For safety reasons, the doors are interlocked with the rotor, the mill cannot be started as long as the doors are opened.

Customer benefits

- High production flexibility
- High throughputs with excellent grinding quality
- User-friendly maintenance, reduced downtime

Granulex™ 3 Series.

Details, technical data and dimensions.



Large sliding doors for quick and easy access to all exchangeable wear/spare parts.

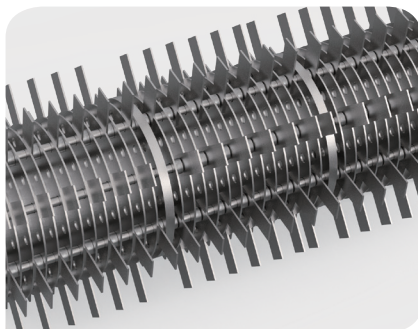

The clearance between hammer and screen is adjustable to meet the requirements of different raw material and fineness.

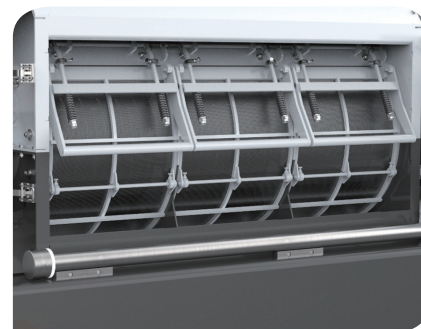

Screen clamping mechanism adopts fast opening design and the screens can be exchanged without any tools.

Technical data

Type	AHZA66050	AHZA66075	AHZA66100	AHZA66125	AHZA66150
Power (kw)	37-75	75-90	90-160	160-200	200-315
Throughput*(t/h)	7-12	12-15	15-27	27-35	35-52

* Depending on raw material and required granulation.

Dimensions

Type	A	B	C	D	E	F	G1	G2	H	I
AHZA66100	676	571	1445	1170	1370	2656	2896	-	1258	1200
AHZA66150	722	566	1445	1168	1378	3508	3433	3633	1797	1511

* See engineering documents for dimensions of other types.

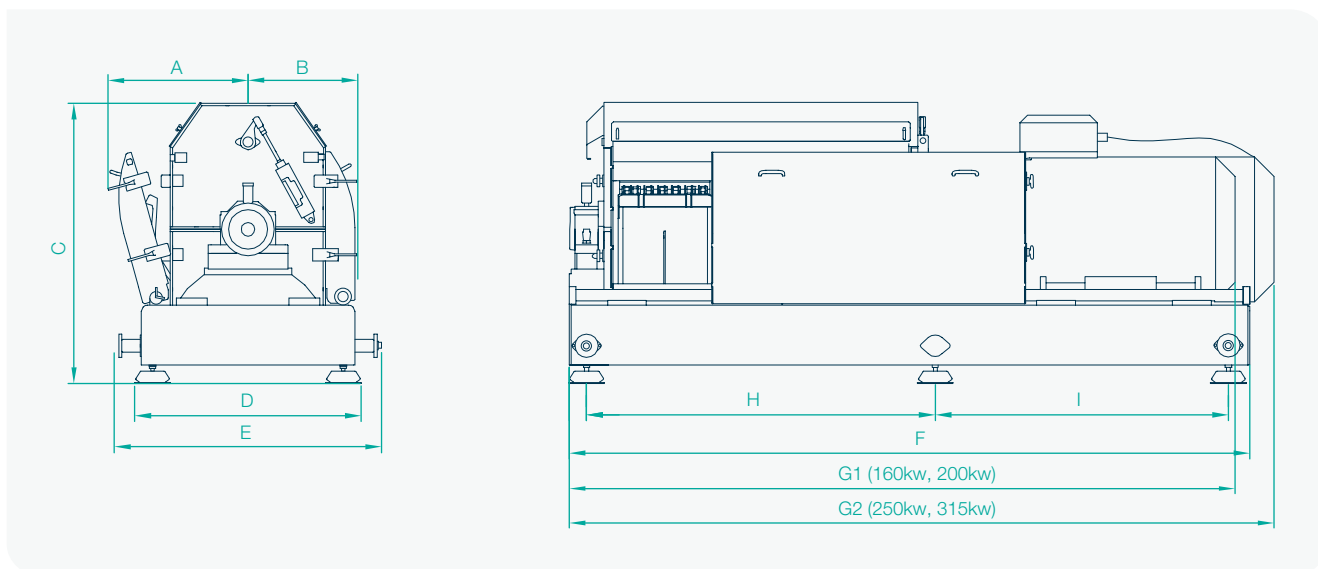

Bühler (Changzhou) Machinery Co., Ltd.

No.88, Yunmei Road, Tianmu Lake Industrial Park,
213332, Liyang, Jiangsu, China

Tel : +86 519 8796 6666

Fax: +86 519 8796 6000

Email: buhler.bcha@buhlergroup.com

<http://www.buhlergroup.com/feed>