

ARA 85|BM 120

**Ersatzteilliste
Reinigungsautomat**

**Spare parts list
Scrubber dryer**

**Catalogue des pièces de rechange
Auto-laveuse**

**Elenco pezzi di ricambio
Lavasciuga pavimenti**

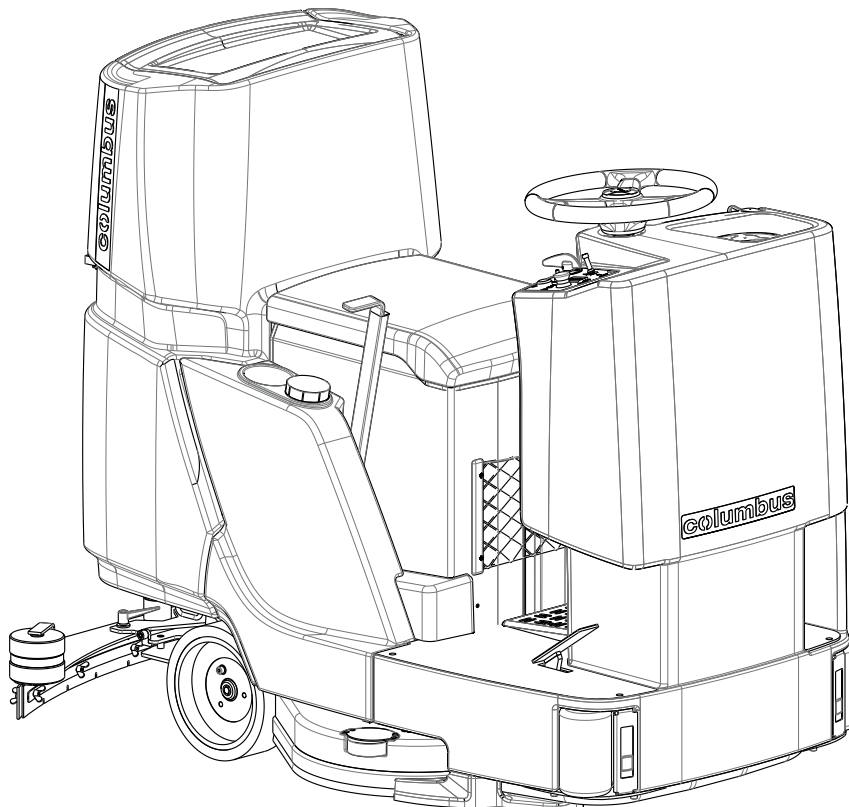

Frischwasser-Tank

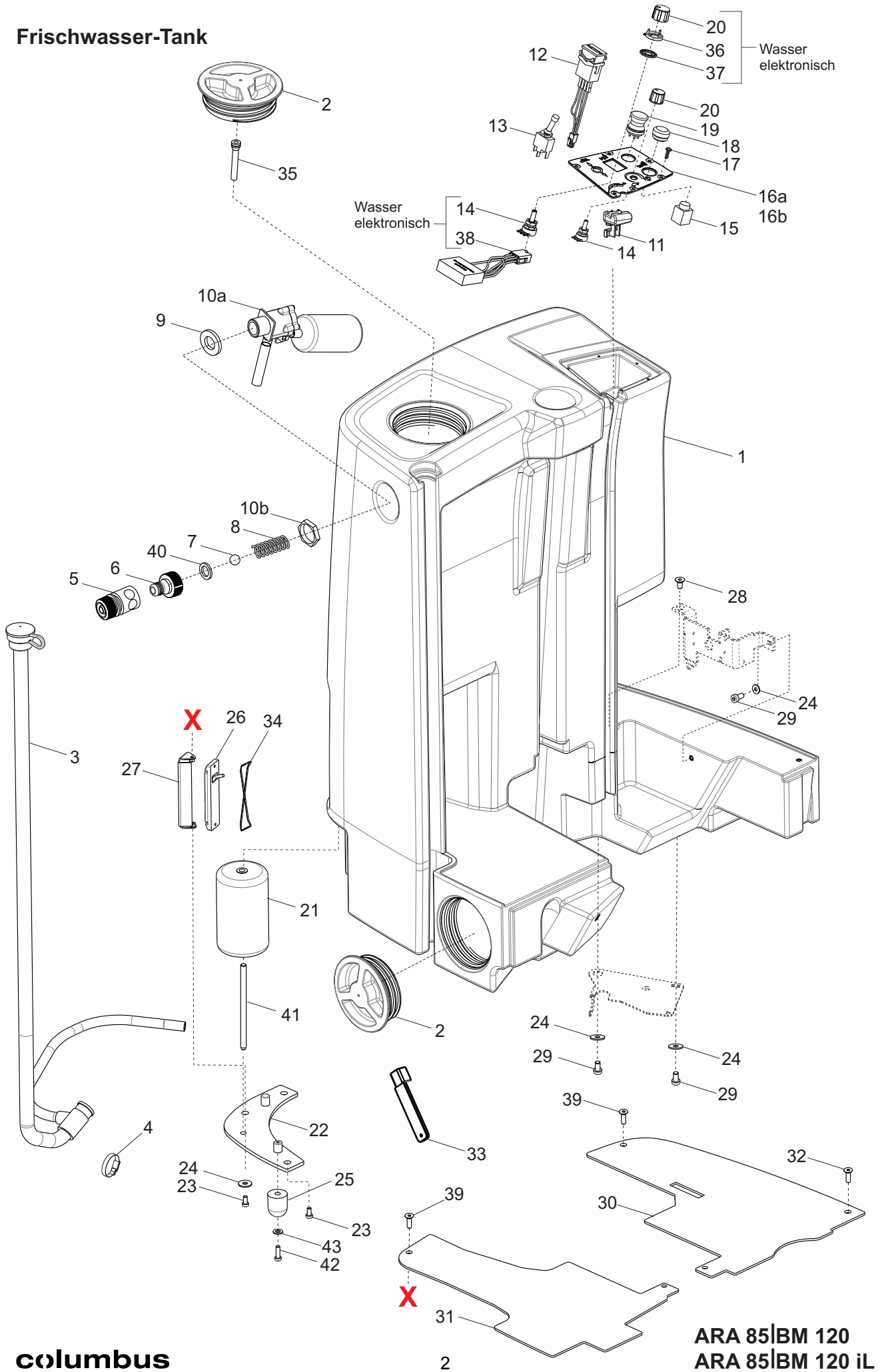

Frischwasser-Tank

Pos.	Art.Nr.	Stück	Bezeichnung	Description	Designation	Descrizione
1	21460601	1	FW-Tank	solution tank	Réservoir eau fraîche	serbatoio soluzione detergente
	70074202	1	Aufkleber columbus	label	Autocollant	etichetta
2	21368300	2	Tank-Schraubdeckel	screwed lid	Couvercle vissée	coperchio filettato
3	21464600	1	FW-Ablassschlauch PU L=1104	drain hose	Flexible de vidange	tubo scarico
4	20959400	1	Schlauschelle W420-32/9	hose clamp	Collier	fascetta tubo
5	21070900	1	Gardena Wasserstopp	water stop	Arrêt autom. de l'eau	acqua stop
6	21070800	1	Gardena-Hahnstück G3/4"	stop cock	robinet	acqua stop
7	21155700	1	Kugel Ø13 PP	ball	balle	palla
8	21155800	1	Druckfeder VD-090U-12	tension spring	Ressort de compr.	molla di compress.
9	21172100	2	Gummidichtung 1/2"	rubber gasket	joint en caoutchouc	guarnizione di gomm.
10a	21058300	1	Schwimmer	float	Flotteur	galleggiante
10b			Messingmutter	nut	écrou	dado
11	21173500	1	Formstück	guide	guide	guida
12	20982100	1	Batteriewächter mit Diode	battery-charge control	surveillance décharge de batterie	controllo scarica batteria
13	20921400	1	Kippschalter mit Kappe	normal-revers rocker switch	interrupteur à bascule avant-arrière	commutatore direzione di marcia
14	21168700	1	Potentiometer 100KOhm-16	potentiometer	potentiomètre	potenziometro
15	21171900	1	Schaltelement	switch element	élément de commutation	elemento di commutazione
16a	21170400	1	Bedienplatte vorne manuell	panel	panneau	pannello
	21170501	1	Bedienschild vorne manuell	label	plaque	cartello
	50644900	0,5 m	Zellgummi-Band	seal	Joint	guarnizione
16b	21170401	1	Bedienplatte vorne el.	panel	panneau	pannello
	21170500	1	Bedienschild vorne el.	label	plaque	cartello
	50644900	0,5 m	Zellgummi-Band	seal	Joint	guarnizione
17	20816200	6	Schraube KA 50x16 EJ schw	screw	Vis	vite
18	21171800	1	Drucktaster m.Schutzkappe	push button	bouton	botone
19	21171700	1	NOT-HALT-Taster	emergency stop button	bouton arrêt-d'urgence	tasto arresto di soccorso
20	21168830	1	Potentiometerknopf D23	potentiometer button	bouton potentiomètre	botone potenziometro
21	21032800	2	Abweisrolle FW-Tank	protecting caster	Roulette de protect.	ruota di protezione
22	21461700	2	Halteplatte Abweisrolle	holder plate	plaque de support	piano di supporto
23	20567500	7	Zylinderschraube M 6x14 VA	cylindrical-head scr.	Vis cylindrique	vite a testa cilindrica
24	20113000	6	Scheibe 6,4x17,6x1,5 VA	washer	Rondelle	rondella
25	21464801	1	Abweiser links	deflector	défecteur	deflettore
26	21462500	2	LED (light-emitting diode)	LED (light-emitting diode)	DEL (diode électroluminesc.)	LED (diodo emettitore di luce)
27	21461800	2	Adapter-LED	adaptor LED	adapteur DEL	adattore LED
28	20636900	1	Senkschraube M6x12 V2A	countersunk screw	Vis à tête noyée	vite a testa svasata
29	20151900	3	Zylinderschraube M6x12 VA	cylindrical-head scr.	Vis cylindrique	vite a testa cilindrica
30	21462800	1	Trittbloch rechts	step plate left	marchepied gauche	montatoio sinistra
31	21462700	1	Trittbloch links	step plate right	marchepied droite	montatoio destra
32	20220000	1	Senkschraube M 6x16 V4A	countersunk screw	Vis à tête noyée	vite a testa svasata
33	21032600	1	Schlüssel f.Schraubdeckel	key for lid	Clé pour couvercle	chiave per il tappo serbatoio
34	21464500	2	Gummiring	rubber ring	caoutchouc	elastico
35	21046400	1	Knickschutztülle D9	tension relief	douille	becco
36	21342000	1	Rastfeder	washer	Rondelle	rondella
37	21341900	1	Rastscheibe	washer	Rondelle	rondella
38	21417500	1	Elektronik Wasserdosierung	electronics water dosage	électronique dosage de l'eau	elettronica dosaggio dell'acqua

Frischwasser-Tank

Pos.	Art.Nr.	Stück	Bezeichnung	Description	Designation	Descrizione
39	21076400	2	Senkschraube M 6x30 VA	countersunk screw	Vis à tête noyée	vite a testa svasata
40	21505900	1	Gummidichtung 16x24,5x3	rubber gasket	joint en caoutchouc	guarnizione di
41	21462100	2	Achse Abweisrolle	axle	axe	asse
42	20831600	1	Zylinderschraube M 6x35	cylindrical-head screw	Vis cylindrique	vite a testa cilindrica
43	20000700	1	Scheibe 6,4x12,0x1,5	washer	Rondelle	rondella

Lenkeinheit

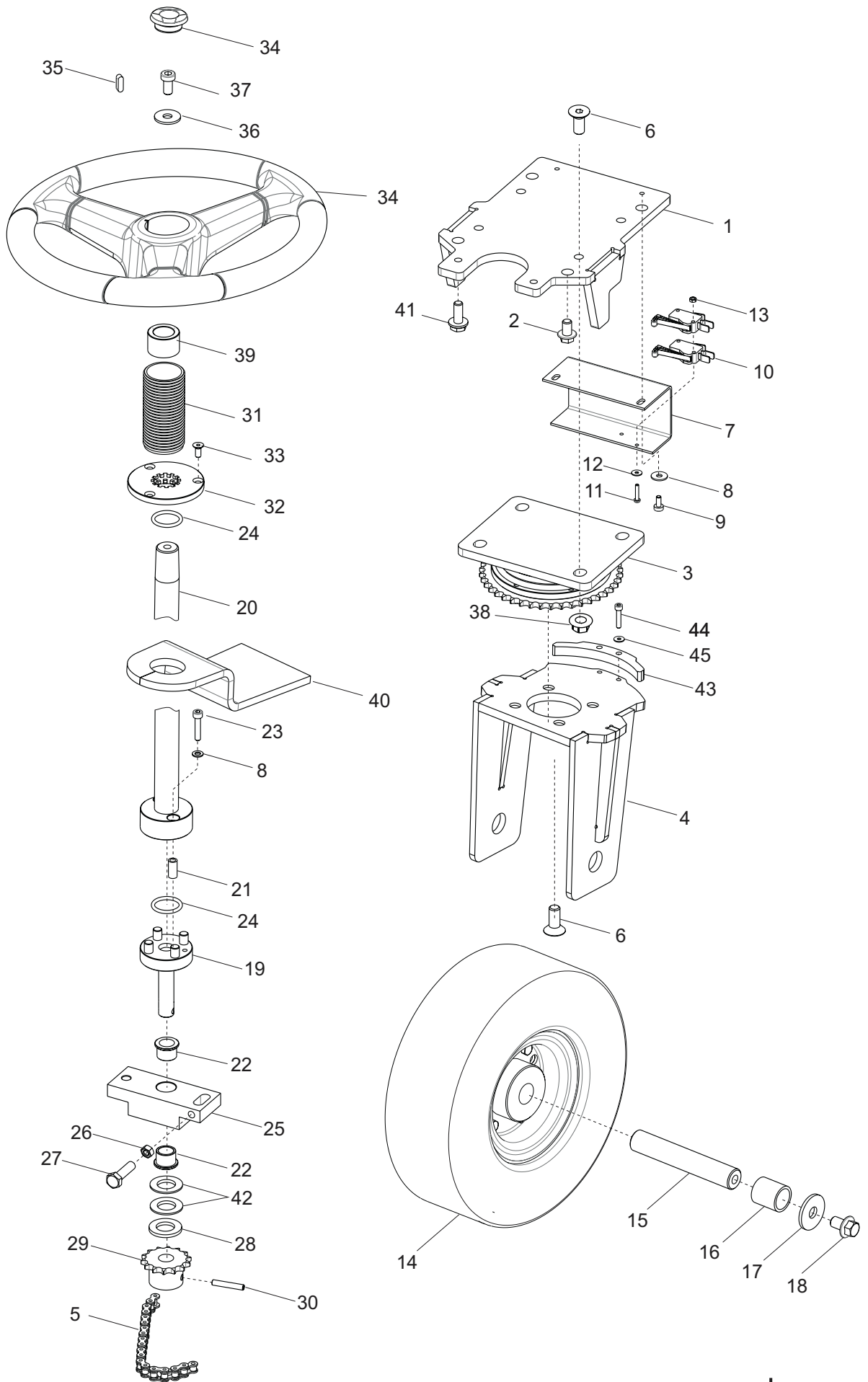

Lenkeinheit

Pos.	Art.Nr.	Stück	Bezeichnung	Description	Designation	Descrizione
1	21165500	1	Trägerplatte	base plate	plaque base	placca basa
2	20682200	4	Verbusschraube M8 x16 Zn	hex.head screw	Vis à tête hex.	vite a testa esagonale
3	21165730	1	Drehkranz mit Kettenrad Z48	live ring w.chain wheel	Couronne giratoire	corona girevole
4	21165600	1	Radhalter	support wheel	Support roue	supporto ruota
5	21171300	1	Rollenkette 06B-1 51 Glied	roller chain	Chaîne articulée	catena a rulli
	21171310	1	Verschlussglied 06B-1 ger.	locking element	L'élément de fermeture	elemento di chiusura
	21171312	1	Verschlussglied 06B-1 gekröpft	locking element	L'élément de fermeture	elemento di chiusura
6	21171500	8	Senkschraube M10x25 VA	countersunk screw	Vis à tête noyée	vite a testa svasata
7	21165800	1	Halter Microschalter	support micro switch	support microrupteur	supporto microcommutatore
8	20009600	4	Scheibe 5,3x10,0x1,0	washer	Rondelle	rondella
9	20730900	2	Zylinderschraube M5x10 VA	cylindrical-head screw	Vis cylindrique	vite a testa cilindrica
10	20958800	2	Microschalter 1006.1514	microswitch	microcommutateur	microinterruttore
11	20114000	2	Linsenschraube M 3x25 VA	lens screw	Vis à tête bombée	vite a testa lenticolare
12	20165400	2	Sicherungsscheibe SMZ 3 Zn	lock washer	Rondelle de blocage	anello di sicurezza
13	20011500	2	6-Kantmutter M 3	hex.nut	écrou hexagonal	dado esagonale
14	21417600	1	Vorderrad D250 m.Kugellag.	front wheel	Roue avant	ruota anteriore
15	20972700	1	Radachse	wheel axle	Essieu-axe	asse della ruota
16	21171600	2	Distanzhülse 25x20x27	spacer	douille d'écartement	distanziale
17	20627600	2	Scheibe 11,0x34,0x3 VA	washer	Rondelle	rondella
18	20983400	2	Verbusschraube M 10x16 Zn	hex.head screw	Vis à tête hex.	vite a testa esagonale
19	21166000	1	Lenkachse	steering axle	essieu pilotante	asse sterzante
20	21166301	1	Lenkstange	steering rod	bielle	asta di guida
21	21171400	2	Distanzstück	spacer	entretoise	distanziale
22	20667400	2	Bundbuchse BB141814	flange adaptor	douille à collet	camicia
23	20186400	2	Zylinderschraube M5x25 VA	cylindrical-head screw	Vis cylindrique	vite a testa cilindrica
24	20093300	2	O-Ring 22x3	O-ring	Joint rond	anello di tenuta
25	21165900	1	Spannklötz	clamping block	bloc de serrage	blocco di serraggio
26	20000500	1	6-Kantmutter M 8	hex. nut	Ecrou	dado essag.
27	20186200	1	6-Kantschraube M8x30 Zn	hexagon screw	Vis à tête hex.	vite esagonale
28	21261700	1	Distanzring	spacer	bague entretoise	anello distanziatore
29	21171200	1	Kettenrad Z10	chain wheel	Roue dentée à chaîne	rocchetto per catena
30	20667800	1	Spiral-Spannstift 5x30	spiral pin	Groupille	spina di fissaggio
31	20135101	1	Abdeckung für Lenkachse	blind	Blende	blenda
32	20666700	1	Lenkbuchse PA	steering bush	Douille	canna
33	20816200	3	Schraube KA 50x16 EJ schw	screw	Vis	vite
34	21385600	1	Lenkrad D350	steering wheel	Volante	volante di guida
	70116702	1	Aufkleber Lenkrad	sticker	Autocollant	etichetta
35	20666900	1	Passfeder 5x5x16	feather key	Ressort d'ajustage	linguetta di aggiust.
36	20277800	1	Scheibe 9,0x28,0x3 VA	washer	Rondelle	rondella
37	20195300	1	Verbusschraube M 8x20 Zn	hex.head screw	Vis à tête hex.	vite a testa esagonale
38	20681700	4	Verbussmutter M10	hex.nut	écrou hexagonal	dado esagonale
39	21261100	1	Hülse	sleeve	douille	boccola
40	21261000	1	Abdeckung	cover	Couverture	copertura

Lenkeinheit

Pos.	Art.Nr.	Stück	Bezeichnung	Description	Designation	Descrizione
41	20195300	2	Verbusschraube M8x20 Zn	hex.head screw	Vis à tête hex.	vite a testa esagonale
42	20667500	2	Pass-Scheibe 14x20x0,5 VA	shim ring	Rondelle d'ajustage	rondella di aggiustamento
43	21416800	1	Steuerkurve	control curve	came de commande	curva fiscale
44	20009400	2	Zylinderschraube M5x20 VA	cylindrical-head screw	Vis cylindrique	vite a testa cilindrica
45	20067400	2	Sicherungsscheibe SMZ 5	lock washer	Rondelle de blocage	anello di sicurezza

Schmutzwasser-Tank

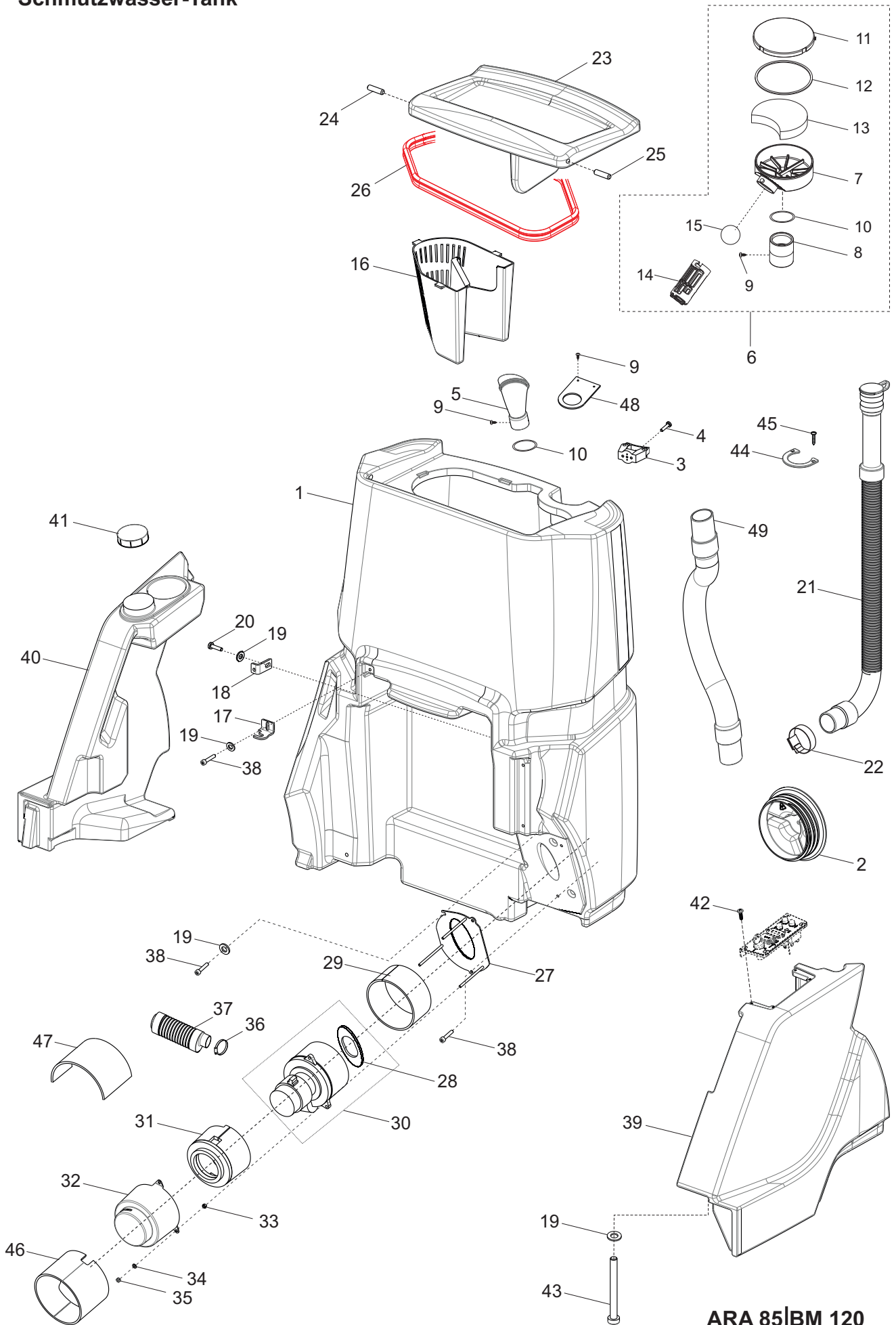

columbus

**ARA 85|BM 120
ARA 85|BM 120 iL**

Schmutzwasser-Tank

Pos.	Art.Nr.	Stück	Bezeichnung	Description	Designation	Descrizione
1	21460701	1	SW-Tank	recovery tank	réservoir de récupération	serbatoio soluzione recup.
2	21368300	1	Tank-Schraubdeckel	screwed lid	Couvercle vissée	coperchio filettato
3	20557700	2	Toolflex-Halterung 20-30mm	tool support	Support pour util	supporto utensile
4	20730900	4	Zylinderschraube M 5x10 VA	cylindrical-head scr.	Vis cylindrique	vite a testa cilindrica
5	21174000	1	Fitting	fitting	raccord	raccordo
6	21058835	1	Prefilter und Schwimmer	prefilter-floater	Préfiltre-floteur	prefiltro-galleggiante
7	21058600	1	Prefiltertopf	suction box	Pot d'aspiration	vaso aspirante
8	21074800	1	Fitting gerade	fitting	Racord	adattamento
9	20048300	5	Blechschr.Li C 2,9x6,5 VA	screw	Vis	vite
10	20063400	2	O-Ring 25x2	O-ring	Garniture	guarnizione
11	21058700	1	Prefilterdeckel	cover	Couvercle	coperchio
12	21075201	1	Rundschnurring D2/110	seal	Garniture	guarnizione
13	21061600	1	Prefilter	prefilter	Préfiltre	prefiltro
14	21058800	1	Schwimmerkorb	float body	corps floteur	corpo galleggiante
15	21058900	1	Ball Ø40	ball	Billes	palla
16	21174100	1	Grobschmutzkorb	waste container	vano di raccolta	vano di raccolta
17	21462300	1	Befestigungswinkel rechts	mounting bracket	cornière	squadretta
18	21462400		Befestigungswinkel links	mounting bracket	cornière	squadretta
19	20113000	5	Scheibe 6,4x17,6x1,5 VA	washer	Rondelle	rondella
20	20682200	2	Verbusschraube M 8x16 Zn	hex.head screw	Vis à tête hex.	vite a testa esagonale
21	20975701	1	SW-Ablaufschlauch PU	drain hose	Tuyau de vidange	tubo scarico
22	20815400	1	Schlauchselle W4 50-70/9	hose clamp	Collier	fascetta per tubi flessibili
23	21461000	1	SW-Deckel	tank cover	couvercle réservoir	coperchio serbatoio
24	20978400	1	Deckelbolzen L39	lid bolt, right	Boulon, droite	bullone, a destra
25	20978401	1	Deckelbolzen L50	bolt	Boulon	bollone
26	50798500	1,1 m	Dichtprofil	band sealer	Joint	profilato di tenuta
27	21462000	1	Halter Saugaggregat	support	support	supporto
28	21462600	1	Dichtung oval	gasket	Rondelle	guarnizione
29	21262601	1	Schalldämmring silent	sound insulation	amortisseur de bruit	silenziatore
30	20543434 20543436	1	Saugaggregat 24V 540W Saugaggregat 34V silent	suction motor	Moteur d'aspiration	motore aspirazione
31	20937700	1	Schalldämmung	sound insulation	amortisseur de bruit	silenziatore
32	20937600	1	Schalldämmhaube	cap for sound insulation silent	chape d'amortisseur silent	cappello silenziatore
33	20002000	3	6-Kantmutter M 6 VA	hex. Nut	Ecrou	dado essag.
34	20000700	3	Scheibe 6,4x12,0x1,5 VA	washer	Rondelle	rondella
35	20070000	3	6-Kantmutter M 6 stop VA	hex. Nut	Ecrou	dado essag.
36	20219700	1	Schlauchselle W4 32-50/9	hose clamp	Collier	fascetta per tubi flessibili
37	20975500	1	Schalldämpfer	sound insulation	Amortisseur de bruit	silenziatore
38	20567500	4	Zylinderschraube M 6x14 VA	cylindrical-head scr.	Vis cylindrique	vite a testa cilindrica
39	21460800	1	Seitenteil links	side part left	pièce latérale gauche	parte laterale sinistra
40	21460900	1	Seitenteil rechts	side part right	pièce latérale gauche	parte laterale destra
41	21173700	1	Schraubdeckel Chemietank	screwed lid	Couvercle vissée	coperchio filettato
42	20816200	4	Schraube KA 50x16 EJ schw	screw	Vis	vite
43	20041700	2	Zylinderschraube M 5x50 VA	cylindrical-head scr.	Vis cylindrique	vite a testa cilindrica
44	20798201	1	Halter für SW-Ablaufschlauch	support	Support	supporto
45	20279800	2	Schraube 3,5x19	screw	Vis	vite
46	21464400	1	Schalldämmring dünn	sound insulation	amortisseur de bruit	silenziatore
47	21464402	1	Spritzschutz	splash guard	Pare-éclaboussures	paraspruzzi
48	20979700	1	Abstandshalter Saugrohr	distancer	espaceur	distanziale
49	20643634	1	Saugschlauch NW38 L=610	suction hose	Flexible d'aspiration	tubo aspirazione

Chassis

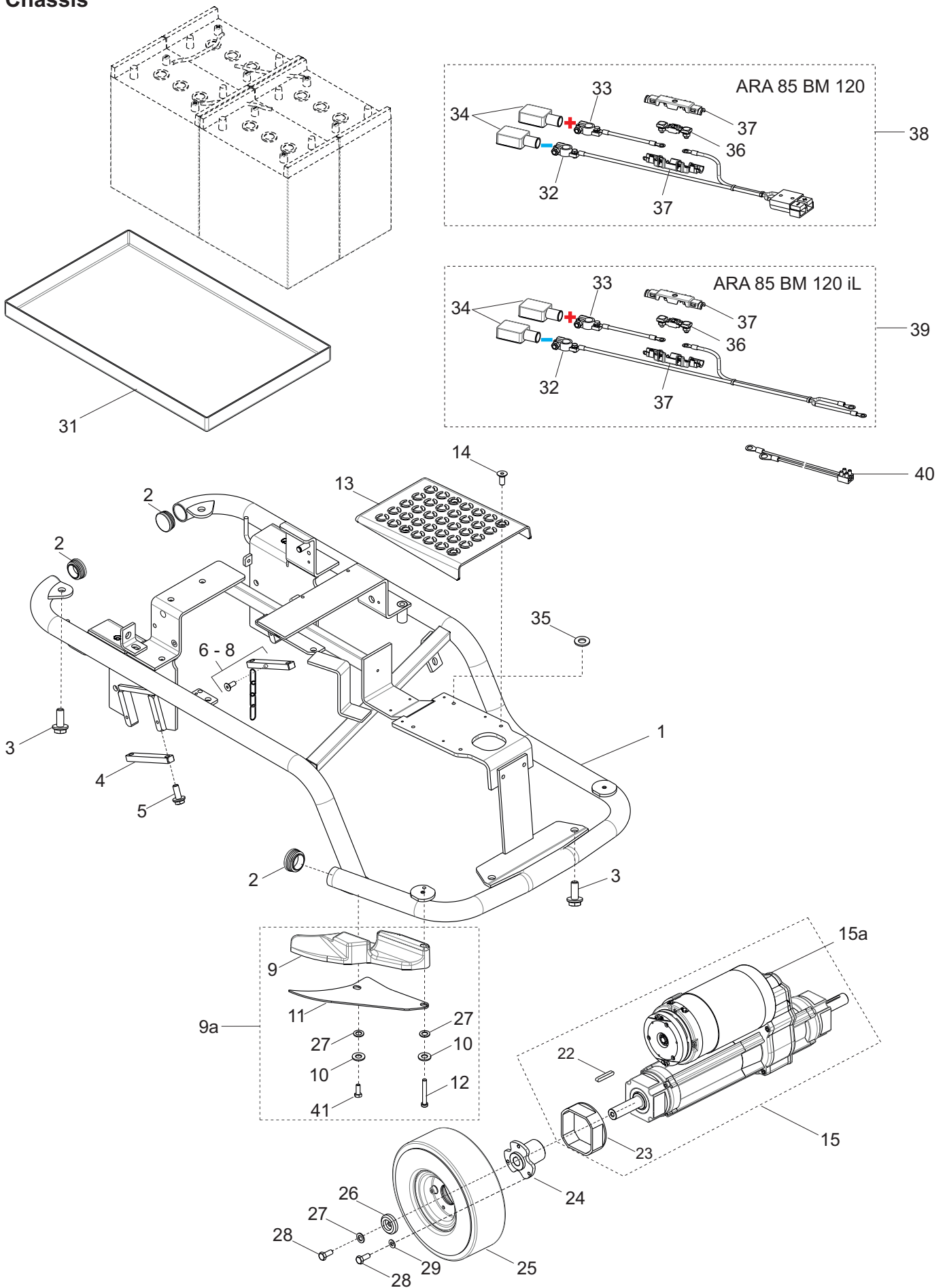

Chassis

Pos.	Art.Nr.	Stück	Bezeichnung	Description	Designation	Descrizione
1	21461530	1	Chassis	chassis	chassis	telaio
2	20975300	3	Lamellenstopfen D40	stopper	Bouchon	tappo
3	20682200	7	Verbusschraube M8x16	hex.head screw	Vis à tête hex.	vite a testa esagonale
4	21251800	1	Halter Fahrtrieb	support drive	support moteur traction	supporto motore traz.
5	20195300	4	Verbusschraube M8x20 Zn	hex.head screw	Vis à tête hex.	vite a testa esagonale
6	21251801	1	Halter Fahrtrieb mit M5	support drive	support moteur traction	supporto motore traz.
7	20630207	1	Kette 3x26 V2A 4 Glieder	chain	Châine	cerniera
8	20002800	1	Senkschraube M 5x12 VA	cylindrical-head scr.	Vis cylindrique	vite a testa cilindrica
9	21464300	1	Abweiser rechts	deflector	défecteur	deflettore
9a	21464330	1	Abweiser rechts kpl.	deflector compl.	défecteur compl.	deflettore compl.
10	20633700	2	Scheibe 8,4x24,0x2,0	washer	Rondelle	rondella
11	21464301	1	Einlage Abweiser rechts	stiffening plate	plaque de raidissement	piatto di irrigidimento
12	20813400	1	6-Kantschraube M8x70 VA	hexagon screw M8	Vis à tête hex.	vite esagonale M8
13	21247101	1	Trittplatte mittig	plate	Plaque	pannello
14	20002800	4	Senkschraube M 5x12 VA	countersunk screw	Vis à tête noyée	vite a testa svasata
15	21163241	1	Antriebseinheit "A" 750W	traction drive	moteur traction	motore trazione
15a	21163230		Fahrmotor+Bremse"A" kpl.			
22	20374400	2	Passfeder 6x6x40 VA	feather key	Ressort d'ajustage	linguetta di aggiustamento
23	21163000	2	Gummilagerung	rubber bearing	logement	alloggiamento
24	21155101	2	Nabe lang	hub	moyeu	mozzo
25	21416900	2	Rad D250 mit Felge	wheel	Roue	ruota
26	20373501	2	Vorlegescheibe M8	washer	Rondelle	rondella
27	20005500	2	Sicherungsscheibe SMZ 8	lock washer	Rondelle dentée	puleggia dentata
28	20068001	8	6-Kantschraube M8x20 VA	hexagon screw	Vis à tête hex.	vite esagonale
29	20633700	6	Scheibe 8,4x24,0x2 VA	washer	Rondelle	rondella
31	21461400	1	Batteriewanne	battery trough	coffre batterie	vaso per batterie
32	20199400	1	Polschuh minus	binding post "-"	Masse polaire "-"	morsetto "-"
33	20199300	1	Polschuh plus	binding post "+"	Masse polaire "+"	morsetto "+"
34	21163500	2	Schutzkappe Polklemme ger.	protection cover	Capuchon de protection	coperchio di protezione
35	20191100	12	Scheibe 6,5x28,0x2,5 VA	washer	Rondelle	rondella
36	21460300	1	Streifensicherung 200A	fuse	fusible	fusibile
37	21460200	1	Sicherungshalter 200A	fuse holder	Fixation	supporto fusibile
38	21460031	1	Batteriekabel ext. LG	battery cable	cable batterie	cavo batteria
39	21460131	1	Batteriekabel iL	battery cable	cable batterie	cavo batteria
40	21251700	1	Batterie-Ladekabel iL	battery charging cable	câble de recharge	cavo di carica
41	20029200	1	Zylinderschraube M 8x25	cylindric.-head screw	Vis cylindrique	vite a testa cilindrica
42	20277800	1	Scheibe 9,0x28,0x3,0	washer	Rondelle	rondella

Gaspedal

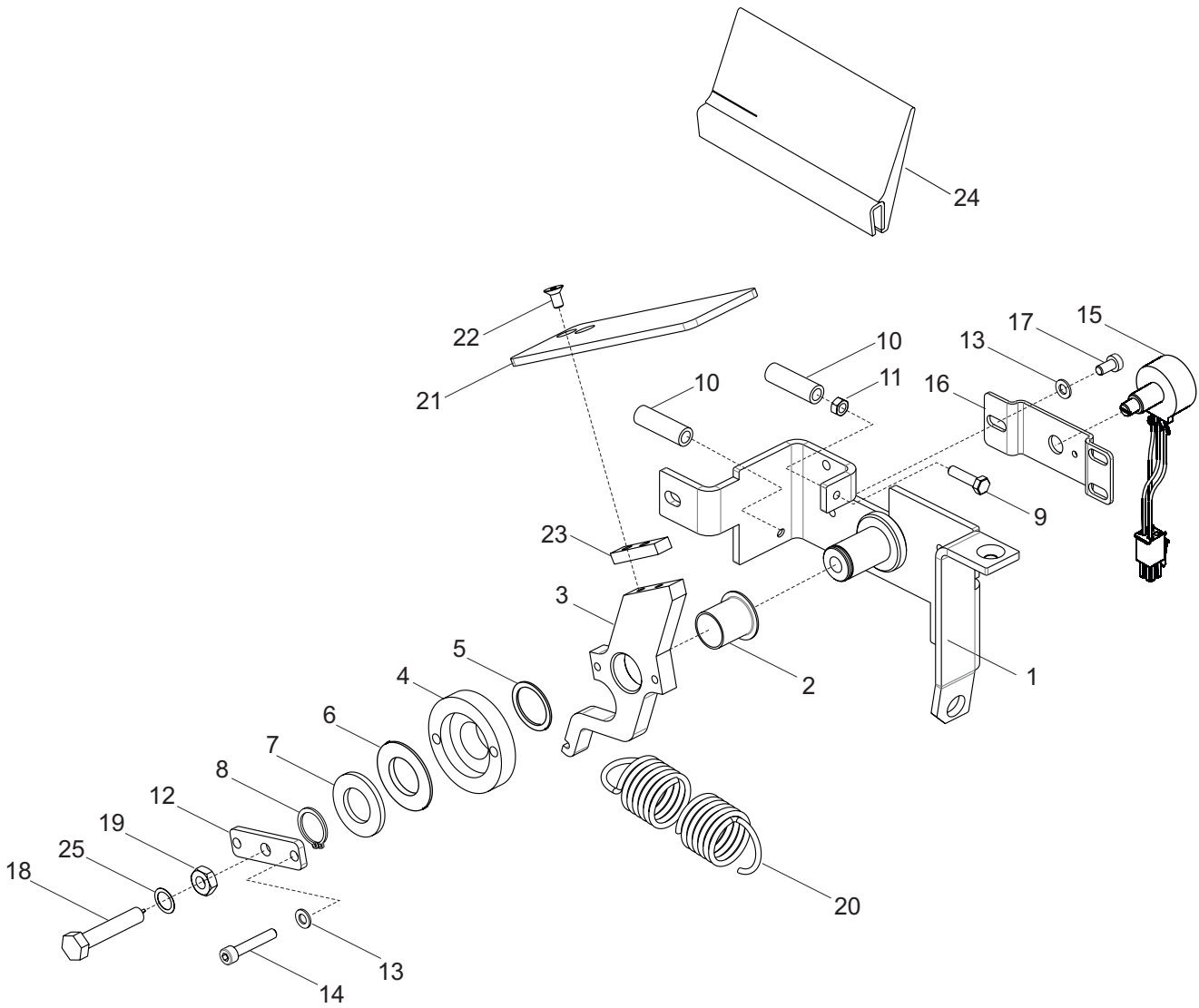

Gaspedal

Pos.	Art.Nr.	Stück	Bezeichnung	Description	Designation	Descrizione
1	21415900	1	Pedalaufnahme	pedal frame	Logement pour pédale	supporto pedale
2	20668700	1	Bundbuchse BB1822DU	flange adaptor	douille à collet	camicia
3	20974400	1	Gaspedal	accelerator	Accélérateur	acceleratore
4	20976901	1	Distanzscheibe Gaspedal	washer	disque d'entretoise	rondella distanziale
5	20075400	1	Pass-Scheibe 20x28x0,3	shim ring	Rondelle d'ajustage	rondella di aggiustamento
6	20222400	1	Kugell.A.Sch.19,3x25,8x0,3	washer	Rondelle	rondella
7	20680300	1	Scheibe 19,0x34,0x3,0 VA	washer	Rondelle	rondella
8	20285100	1	Sicherungsring A FST 18	circlip	Circlips	anello di arresto
9	20102300	1	6-Kantschraube M5x20 Zn	hex.head screw	Vis à tête hex.	vite a testa esagonale
10	20125301	2	Distanzrohr	distancer	Entretoise	distanziale
11	20574300	1	6-Kantmutter M 5 V2A	hex. Nut	Ecrou	dado essag.
12	20973400	1	Platte Stellschraube	plate	Plaque	piastra
13	20009600	5	Scheibe 5,3x10,0x1,0 Zn	washer	Rondelle	rondella
14	20224600	2	Zylinderschraube M5x30 VA	cylindrical-head screw	Vis cylindrique	vite a testa cilindrica
15	20997700	1	Potentiometer m.Kabel	potentiometer	Potentiomètre	potenziometro
16	20974001	1	Halter Potentiometer	support	support potentiomètre	supporto potenziometro
17	20730900	3	Zylinderschraube M5x10 VA	cylindrical-head screw	Vis cylindrique	vite a testa cilindrica
18	20771200	1	Stellschraube	adjusting screw	Vis de réglage	vite di regolazione
19	20297300	1	6-Kantmutter M 8 Zn flach	hex.nut	écrou hexagonal	dado esagonale
20	20977400	1	Zugfeder Z-121 GI	tension spring	ressort de traction	molla di trazione
21	20973300	1	Platte Gaspedal	accelerator plate	Plaque pour accélérateur	piastra
	50771100	0,15m	Gleitschutzband	sand paper	Papier sablé	crtta vetrata
22	20086500	2	Senkschraube M5x16 V2A	countersunk screw	Vis à tête noyée	vite a testa svasata
23	21261200	1	Zwischenplatte	plate	Plaque	piastra
24	51171900	0,12m	Kantenschutzprofil	edge protection	Protection de arêtes	profilo di protezione
25	20005500	1	Sicherungsscheibe SMZ 8 Zn	lock washer	Rondelle de sécurité	anello d'arresto

Elektrik

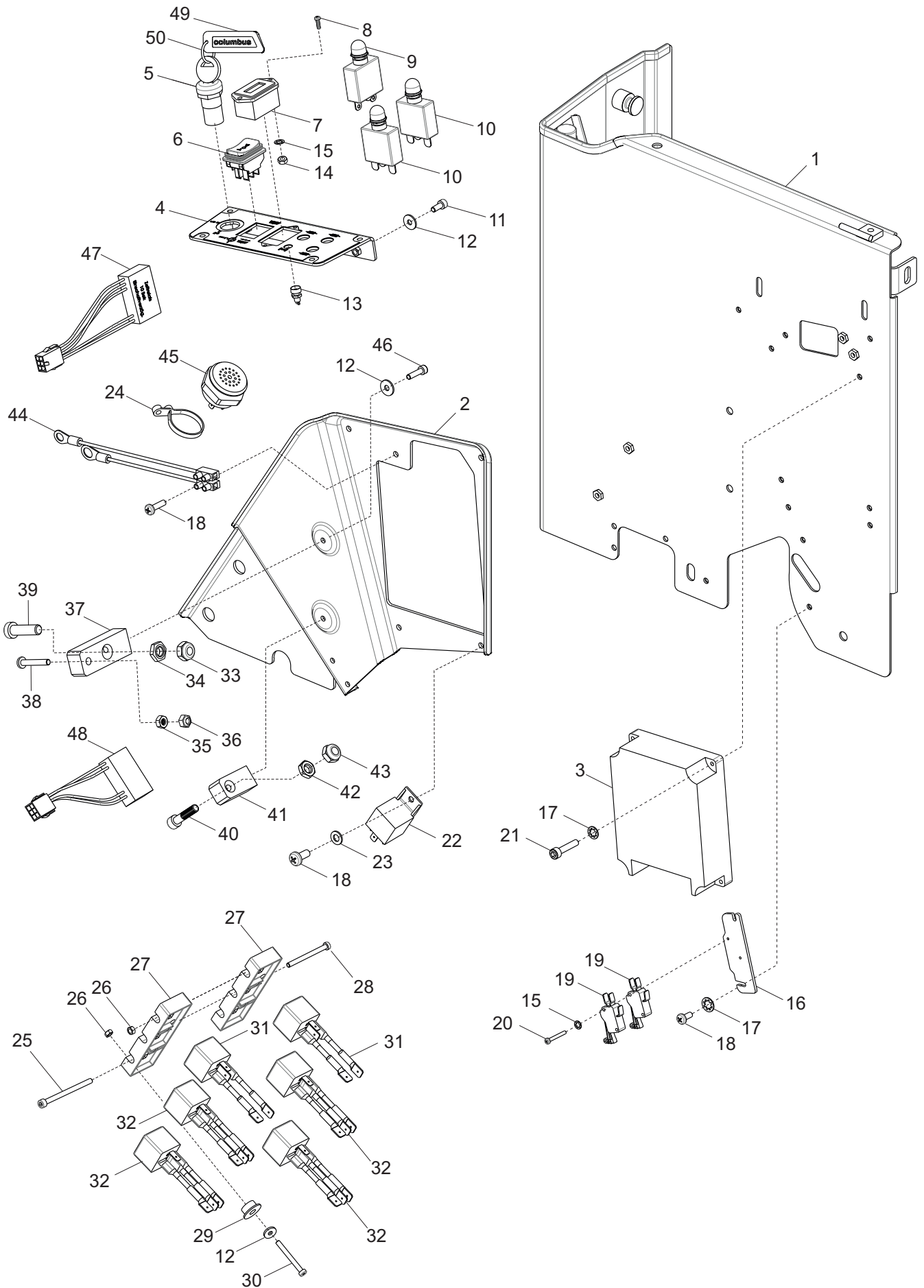

Elektrik

Pos.	Art.Nr.	Stück	Bezeichnung	Description	Designation	Descrizione
1	21173003	1	Batterieverkleidung	battery cover	habillage batteries	coperto batterie
2	21400000	1	Zwischenplatte Elektrik	plate	Plaque	piastra
3	20979801	1	Steuerung voreingestellt	driving control device	Commande électron. de marche	comando elettronico marcia
4	21170600	1	Bedienplatte links	panel	panneau	lastra
	21170700	1	Bedienschild links	label	plaque	cartello
	50644900	0,3 m	Zellgummi-Band 15x5	seal	Joint	guarnizione
5	20632500	1	Schlüsselschalter SPE	main switch	interrupteur principal	interruttore principale
6	21064201	1	Wipptaster	switch	interrupteur	interruttore
7	21168200	1	Betriebsstunden-Zähler digital	elapsed hour counter digit	compteur période d'action	contatore durata lavoro
8	20041800	2	Linsenschraube M3x10	lens screw	Vis à tête bombée	vite a testa lenticolare
9	20202401	1	Überstromschutz-Schalter 30A	fuse	Fusible	fusibile
10	21077800	2	Überstromschutz-Schalter 25A	fuse	Fusible	fusibile
11	20149200	2	Zylinderschraube M5x12	cylindrical-head screw	Vis cylindrique	vite a testa cilindrica
12	20183000	10	Scheibe 5,3x15,0x1,4	washer	Rondelle	rondella
13	21159010	1	LED gelb	LED (light-emitting diode)	DEL (diode électroluminescente)	LED (diodo emettitore di luce)
14	20011500	4	6-Kantmutter M 3	hex.nut	écrou hexagonal	dado esagonale
15	20165400	4	Sicherungsscheibe SMZ 3	lock washer	Rondelle de blocage	anello di sicurezza
16	21171001	1	Halter Microschalter	support micro switch	support micro interrupteur	supporto micro interrutt.
17	20060000	6	Sicherungsscheibe SMZ 4 Zn	lock washer	Rondelle de sécurité	anello d'arresto
18	20105700	4	Linsenschraube M4x10 VA	lens screw	Vis à tête bombée	vite a testa lenticolare
19	20958800	2	Microschalter 1006.1514	microswitch	microcommutateur	microinterruttore
20	20114000	2	Linsenschraube M3x25	lens screw	Vis à tête bombée	vite a testa lenticolare
21	20086900	4	Zylinderschraube M 4x20 Zn	cylindrical-head scr.	Vis cylindrique	vite a testa cilindrica
22	21077100	1	Relais m.Diode Wechsler	relay	Relais	relé
23	20009600	1	Scheibe 5,3x10,0x1,0 Zn	washer	Rondelle	rondella
24	20135800	1	Kabelbinder TY35M	cable strip	Attache rapide	strip cavo
25	20818500	2	Zylinderschraube M5x70 VA	cylindrical-head screw	Vis cylindrique	vite a testa cilindrica
26	20574300	5	6-Kantmutter M 5 V2A	hex. nut M 5	Ecrou M 5	dado essag. M 5
27	21155500	2	Halter für Relais 3fach	support relay	Support relais	supporto relé
28	20041700	3	Zylinderschraube M5x50 VA	cylindrical head screw	Vis cylindrique	vite
29	21450500	4	Haltescheibe	retaining washer	Rondelle	rondella
30	20037000	4	Zylinderschraube M5x40 VA	cylindrical-head screw	Vis cylindrique	vite a testa cilindrica
31	21452330	2	Relais m.2 Kabeln	relay	Relais	relè
32	21452331	4	Relais m.3 Kabeln	relay	Relais	relè
33	20682400	2	6-Kantmutter M 10 stopp	hex. Nut	Ecrou	dado essag.
34	20626400	1	6-Kantmutter M 10	hex.nut	Ecrou	dado essag.
35	20007100	1	6-Kantmutter M 4 stopp	hex. Nut	Ecrou	dado essag.
36	20076300	1	6-Kantmutter M4 V2A	hex. Nut	Ecrou	dado essag.
37	21247400	1	Polklemme plus	binding post plus	borne polaire plus	morsetto plus
38	20069000	1	Linsenschraube M4x25	lens screw	Vis à tête bombée	vite a testa lenticolare
39	20141901	1	6-Kantschraube M10x50 VA	hex.screw	Vis à six pans	vite esagonale
40	20191700	1	6-Kantschraube M 8x45 VA	hex.screw	Vis à six pans	vite esagonale
41	20997500	1	Polklemme minus	binding post	Pôle négatif	morsetto negativo
42	20297300	1	6-Kantmutter M 8 VA	hex. Nut	Ecrou	dado essag.

Elektrik

Pos.	Art.Nr.	Stück	Bezeichnung	Description	Designation	Descrizione
43	20280500	2	6-Kantmutter M 8 stopp	hex. Nut	Ecrou	dado essag.
44	21251700	1	Batterie-Ladekabel	battery charging cab.	Câble batterie	cavo di carica batteria
45	21374800	1	Piezo-Buzzer	horn	Claxon	clacson
46	20009400	2	Zylinderschraube M 5x20 VA	cylindrical head scr.	Vis cylindrique	vite a testa cilindrica
47	21078030	1	Zeitrelais-Einschaltverzög 1,5 sec	timing relay	Relais	relé
48	21078031	1	Zeitrelais-Einschaltverzöger. 10 sec	relay	Relais	relè con timer
49	21506100	1	Keil Bremse lösen	brake release wedge	cale de dégagement de frein	cuneo di rilascio freno
50	20016100	1	Schlüsselring klein D20	key ring	porte-clé	anello portachiavi

Fahrersitz

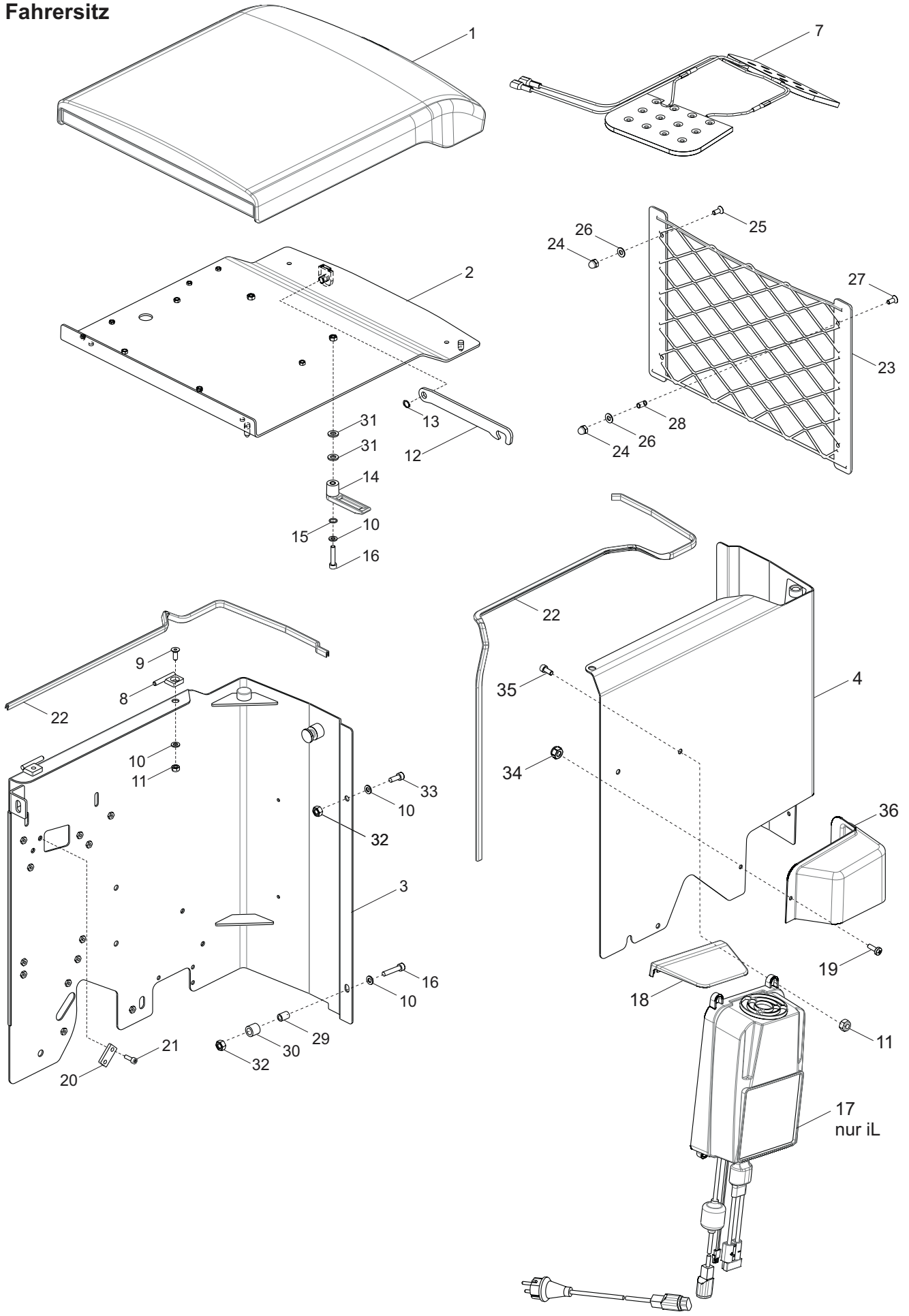

Fahrersitz

Pos.	Art.Nr.	Stück	Bezeichnung	Description	Designation	Descrizione
1	21172800	1	Sitzpolster	seat upholstery	bourellet	sedile imbottito
2	21172902	1	Sitzplatte	seat plate	panneau siège	pannello sede
3	21173003	1	Batterieverkleidung	battery cover	habillage batteries	coperto batterie
4	21461600	1	Batterieabdeckung	battery cover	habillage batteries	coperto batterie
7	20976731	1	Sitzkontaktschalter doppelt	seat switch	interrupteur baquet	interruttore sedile
8	21369600	1	Scharnier	hinge	charnière	cerniera
9	20220000	1	Senkschraube M6x16	countersunk screw	Vis à tête noyée	vite a testa svasata
10	20000700	5	Scheibe 6,4x12x1,5 VA	washer	Rondelle	rondella
11	20070000	2	6-Kantmutter M6 stopp	hex. Nut	Ecrou	dado essag.
12	21176100	1	Hebel	lever	levier	leva
13	20029700	1	Sicherungsring FST 10	circlip	Rondelle de sécurité	anello di sicurezza
14	20319600	2	Kabelhaken	cable hook	crochet pour câble	gancio
15	20930900	2	O-Ring 8,5x1,5	O-ring	Joint ronde	guarnizione
16	20579600	2	Zylinderschraube M 6x30 VA	cylindrical-head screw	Vis cylindrique	vite a testa cilindrica
17	21463000	1	Ladegerät 30A/24V	batterie charger	Chargeur	caricabatteria
18	21462901	1	Abdeckung Ladegerät	support charger	support chargeur	supporto caricabatterie
19	20006500	2	Linsenschraube M 5x10 VA	lens screw	Vis à tête bombée	vite a testa lenticolare
20	21250100	1	Kabelklemme	cable clamp	serre-câble	serracavo
21	20096500	2	Zylinderschraube M 5x16 VA	cylindrical-head screw	Vis cylindrique	vite a testa cilindrica
22	51262700	2,2 m	Kantenschutz	edge protection	protège-arête	protezione
23	21262200	1	Ablagenetz	storage net	réseau de dépôt	rete portaoggetti
24	20059900	4	Hutmutter M 4	cap nut	Ecrou	dado a cappello
25	20001800	2	Senkschraube M4x10	countersunk screw	Vis à tête noyée	vite a testa svasata
26	20000300	4	Scheibe 4,3x9x0,7	washer	Rondelle	rondella
27	20223400	2	Senkschraube M4x12 V2A	countersunk screw	Vis à tête noyée	vite a testa svasata
28	51291700	0,005 m	Schlauch PA Ø6 rot	hose	Tuyau	tubo
29	21163301	1	Buchse D10 x d6,4 x 13,7	sleeve	prise	bussola
30	50046800	0,012 m	Schlauch 10x2	hose	Tuyau	tubo
31	20113000	4	Scheibe 6,4x17,6x1,5 VA	washer	Rondelle	rondella
32	20002000	2	6-Kantmutter M6 VA	hex. Nut	Ecrou	dado essag.
33	20151900	1	Zylinderschraube M 6x12 VA	cylindrical-head screw	Vis cylindrique	vite a testa cilindrica
34	20280600	2	6-Kantmutter M 5 stop VA	hex. Nut	Ecrou	dado essag.
35	20279200	2	Zylinderschraube M 6x16 VA	cylindrical-head screw	Vis cylindrique	vite a testa cilindrica
36	21461101	1	Motorabdeckung Spritzguss	motor cover	Capot moteur	coperchio del motore

Bürstanhebung

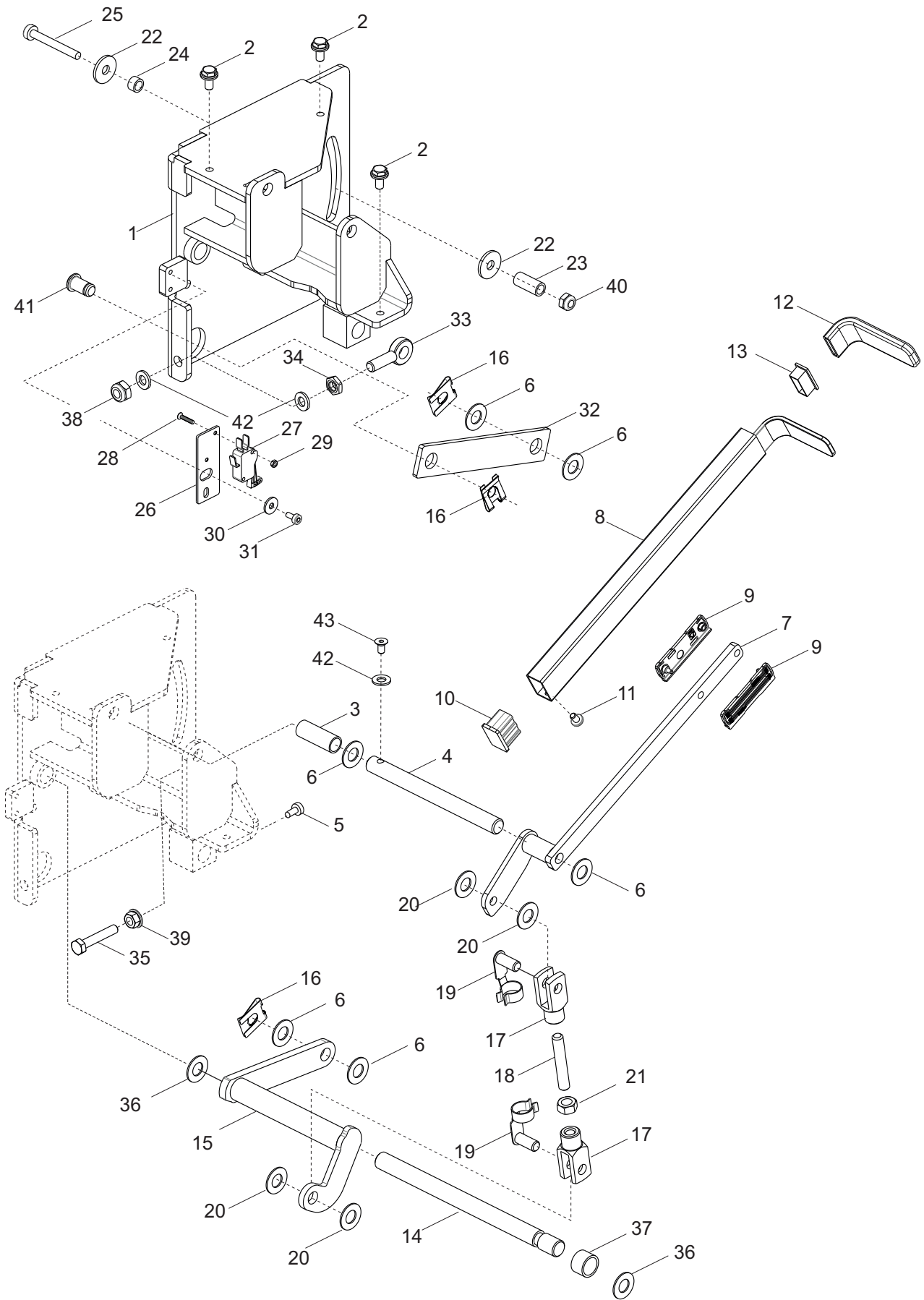

Bürstanhebung

Pos.	Art.Nr.	Stück	Bezeichnung	Description	Designation	Descrizione
1	21167203	1	Basis	base	base	base
2	20682200	3	Verbusschraube M8x16 Zn	hex.head screw	Vis à tête hex.	vite a testa esagonale
3	21246301	1	Distanzbuchse 13x16x44	distance bush	manchon d'espacement	distanziale
4	21253901	1	Achse Bürste	axis	axe	asse
5	20193000	1	Zylinderschraube M6x10 Zn	cylindrical-head screw	Vis cylindrique	vite a testa cilindrica
6	20622600	6	Scheibe 13,0x24,0x2,5 PA	washer	Rondelle	rondella
7	21167702	1	Zwischenhebel	intermediate lever	levier intermédiaire	leva intermedia
8	21167101	1	Betätigungshebel	lever	levier	leva
9	21369100	2	Gleitplatte	sliding plate	plaque coulissante	piastra scorrevole
10	21369000	1	Ausziehsicherung	stop	stop	stop
11	20159300	2	Linsenschraube M4x 6 VA	lens screw	Vis à tête bombée	vite a testa lenticolare
12	20985800	1	Flachkappe 4,9x24x109,6	lever sheathing	Revêtement	ricoprimento
13	21261600	1	Lamellenstopfen 30/15	plug	Bouchon	tappo
14	21167501	1	Hauptachse	main pivot	essieu principal	asse principale
15	21167601	1	Hebelunterteil	lever lower part	levier inférieur	leva inferiore
16	20373800	3	SL-Sicherung 12	safety piece	Collier d'épaulement	pezzo di sicurezza
17	20627200	2	Gabelkopf G10x20	fork head	tête à fourche	testa di forcella
18	21260902	1	Gewindestange M10	screwed bar	Tige filetée	asta filettata
19	20631000	2	Federklappbolzen 10x20	bolt	Boulon	bullone
20	20373700	4	Scheibe 10,5x20,0x2,0 PA	washer	Rondelle	rondella
21	20054400	1	6-Kantmutter M10 VA	hex.nut	écrou hexagonal	dado esagonale
22	20277800	2	Scheibe 9,0x28,0x3 VA	washer	Rondelle	rondella
23	21176600	1	Distanzbuchse 12x8,5x26,5	distance bush	manchon d'espacement	distanziale
24	21176700	1	Distanzbuchse 12x8,5x7	distance bush	manchon d'espacement	distanziale
25	20032400	1	Zylinderschraube M8x60	cylindrical-head screw	Vis cylindrique	vite a testa cilindrica
26	21248000	1	Halter Microschalter	support micro switch	support microrupteur	supporto microcommutatore
27	20958800	1	Microschalter 1006.1514	microswitch	microcommutateur	microinterruttore
28	20816700	2	Senkschraube M3x16 VA	countersunk screw	Vis à tête noyée	vite a testa svasata
29	20011500	2	6-Kantmutter M 3	hex.nut	écrou hexagonal	dado esagonale
30	20112900	2	Scheibe 5,3	washer	Rondelle	rondella
31	20730900	2	Zylinderschraube M5x10	cylindrical-head screw	Vis cylindrique	vite a testa cilindrica
32	21167001	1	Ausgleichshebel	adjustment lever	Levier compensation	leva accomodamento
33	20801500	1	Ringschraube M8	screw M8	Vis M8	vite ad anello M8
34	20000500	1	6-Kantmutter M 8	hex.nut	Ecrou hexagonal	dado essag.
35	20191700	1	6-Kantschraube M8x45 VA	hex.screw	Vis à six pans	vite esagonale
36	20627500	2	Scheibe 17,0x30,0x3 PA	washer	Rondelle	rondella
37	21383700	1	Distanzbuchse	distance bush	manchon d'espacement	distanziale
38	20280500	1	6-Kantmutter M8 STOPP	hex. Nut	Ecrou	dado essag.
39	20045900	1	Verbussmutter M8 Zn	hex.nut	écrou hexagonal	dado esagonale
40	20280500	1	6-Kantmutter M8 STOPP VA	hex. nut	Ecrou	dado essag.
41	20650100	1	Bolzen mit Kopf	bolt	Boulon	bullone
42	20067600	3	Scheibe 8,4x16x1,6 VA	cylindrical-head screw	Vis cylindrique	vite a testa cilindrica
43	20636900	1	Senkschraube M6x12 V2A	countersunk screw	Vis à tête noyée	vite a testa svasata

Bürsteinheit

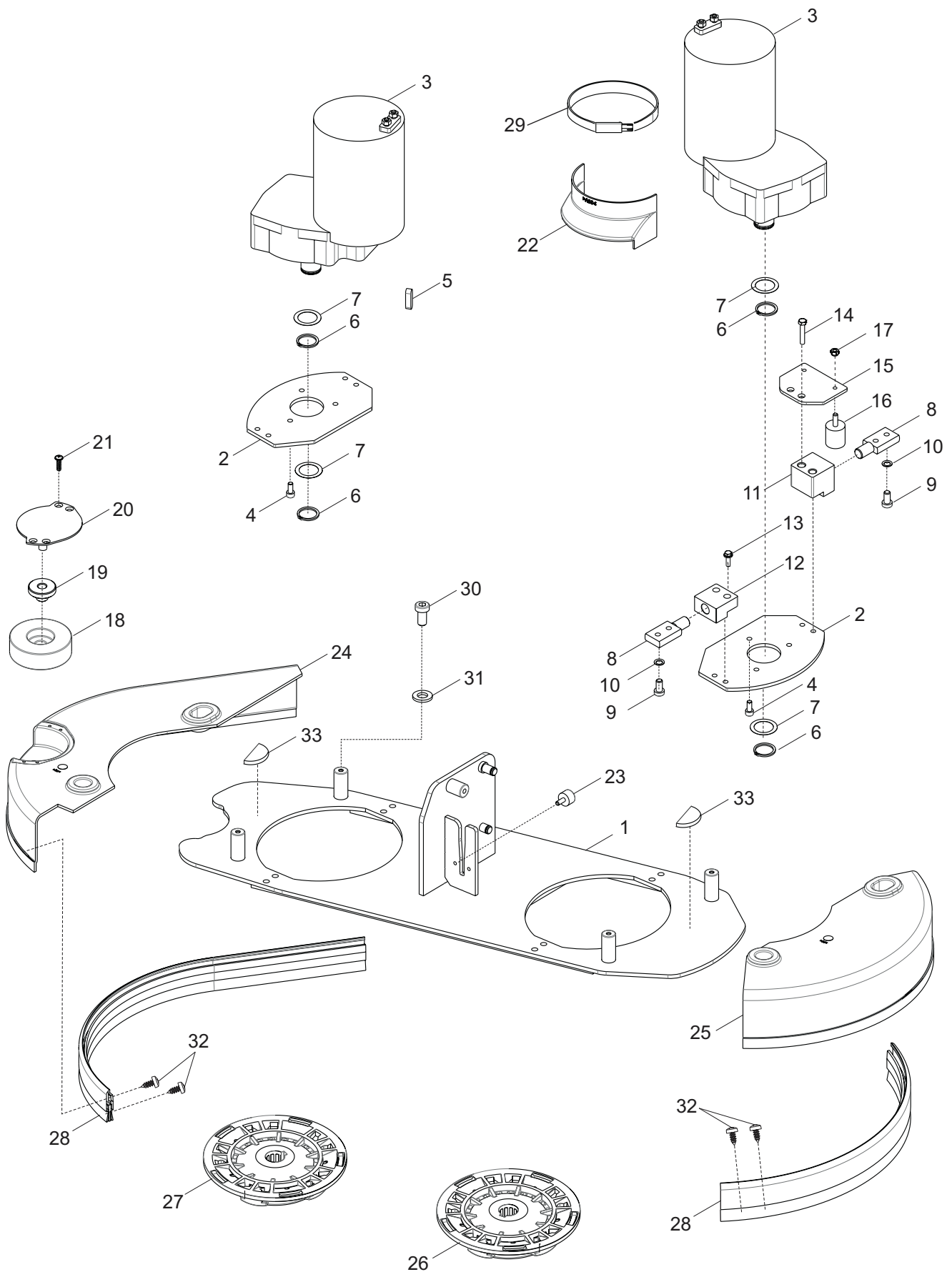

Bürsteinheit

Pos.	Art.Nr.	Stück	Bezeichnung	Description	Designation	Descrizione
1	21461930	1	Bürstplatte mittig	brush plate central	Support central de la brosse	piastra centrale
2	21050400	2	Bürstplatte seitlich	brush plate lateral	Support latérale de la brosse	piastra laterale
3	21387001	2	Bürstenmotor 550W 24V	brush motor	Moteur de brosse	motore
4	20567500	6	Zylinderschraube M6x14 VA	cylindrical head screw	Vis cylindrique	vite
5	21057600	2	Passfeder 8x7x30 VA	feather key	Ressort d'ajustage	linguetta di aggiustamento
6	21057700	4	Sicherungsring AS 25x2 VA	circlip	Rondelle de sécurité	anello d'arresto
7	21045700	4	Pass-Scheibe 25x35x0,2 VA	shim ring	Rondelle d'ajustage	rondella di aggiustamento
8	21050800	4	Gelenk	articulation	Articulation	giunto
9	20152000	8	Zylinderschraube M8x16 VA	cylindrical-head screw	Vis cylindrique	vite a testa cilindrica
10	20005500	8	Sicherungsscheibe SMZ 8	lock washer	Rondelle dentée	puleggia dentata
11	21050700	2	Gelenk abgesetzt	stepped articulation	articulation étagée	giunto
12	21050701	2	Gelenk abgesetzt kurz	articulation short, stepped	articulation courte, étagée	giunto
13	20195300	4	Verbusschraube M8x20	hex.head screw	Vis à tête hex.	vite a testa esagonale
14	20191700	4	6-Kt Schraube M8x45	hex.sccrew	Vis à six pans	vite esagonale
15	21050901	2	Gelenkplatte	plate	Plaque de charnière	piastra
16	21054800	4	Gummi-Metall-Puffer hart	bumper	Tampon	tampone
17	20070000	6	6-Kt Mutter M6 stopp	hex. Nut	Ecrou	dado essag.
18	21053700	2	Abweisrolle D80	protecting caster	Roulette de protection	ruota di protezione
19	21054600	2	Führungsstopfen	stopper	Bouchon	tappo
20	21057900	2	Platte Abweisrolle hoch	plate	Plaque	piastra
21	20681900	8	Schraube 52005TXVS516 schw	screw	Vis	vite
22	21073401	2	Motorabdeckung unten	cover lower part	Couvercle de brosse	copertura
23	21171100	4	Gummi-Puffer M6x15	bumper	Tampon	tampone
24	21461200	1	Bürstabdeckung rechts	brush cover	Couverture de brosse	copertura
25	21461300	1	Bürstabdeckung links	brush cover	Couverture de brosse	copertura
26	21050500	1	Bürstaufnahme rechts grau	Brush unit	Logement pour brosse	alloggiamento
27	21050501	1	Bürstaufnahme links schwarz	Brush unit	Logement pour brosse	alloggiamento
28	21051100	1	Halteprofil mit Bürstenstreifen	fixation profile for brush strips	profile de fixation	profilo fermarsi
29	21075300	2	Schelle 100-120/9 C7 W1	clamp	Collier	morsetto
30	20151900	4	Zylinderschraube M 6x12 VA	cylindrical head screw	Vis cylindrique	vite
31	20191100	4	Scheibe 6,5x28,0x2,5 VA	washer	Rondelle	rondella
32	20048300	4	Blechschr.Li C 2,9x6,5 VA	screw	Vis	vite
33	21462601	1	Abstandhalter aus 21462600	distance piece	entretoise	distanziale

Düsenanhebung

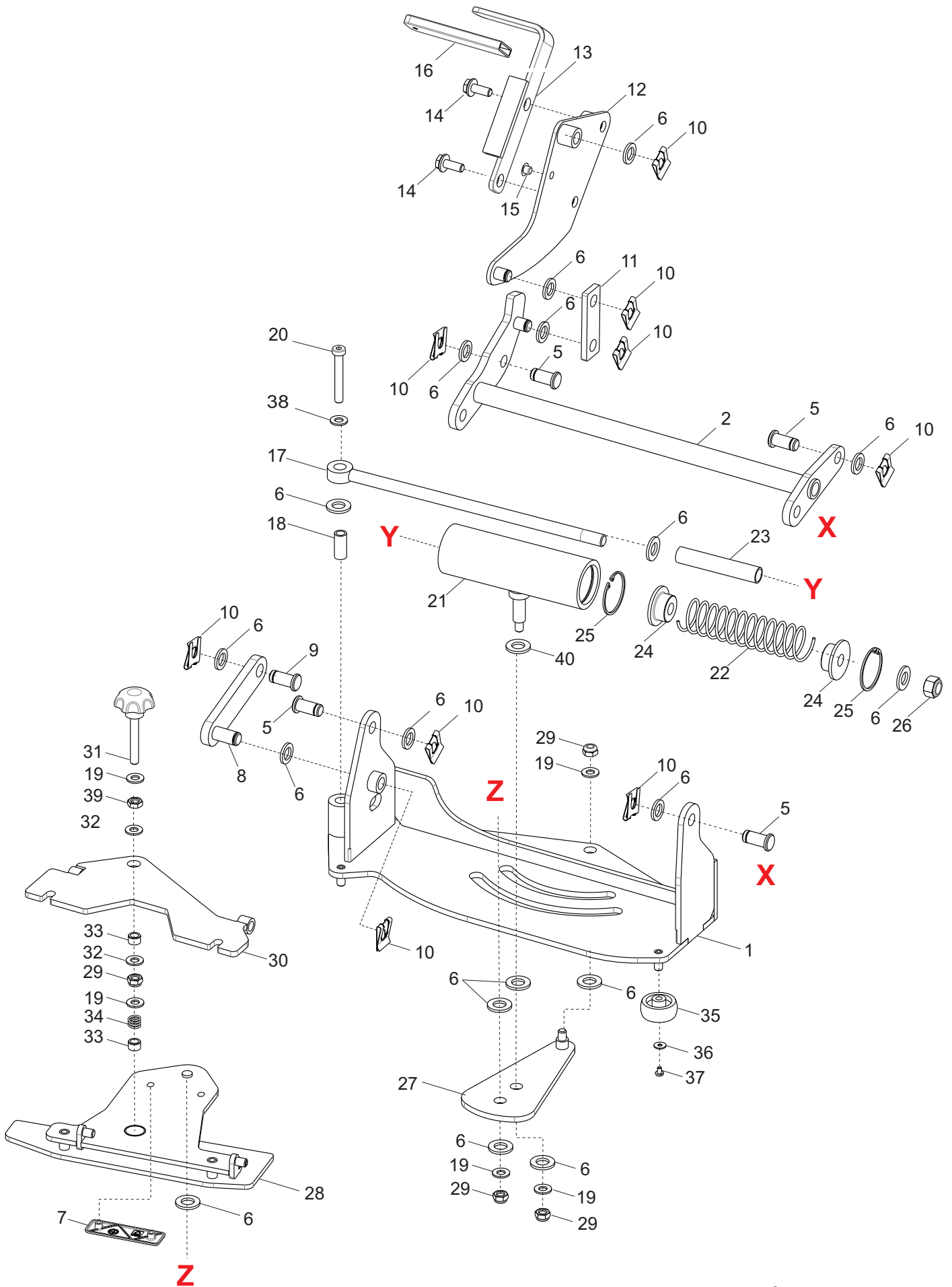

Düsenanhebung

Pos.	Art.Nr.	Stück	Bezeichnung	Description	Designation	Descrizione
1	21207203	1	Basis Düsenanhebung	basis nozzle lifting	base relevage buses	base sollevamento
2	21164602	1	Hebel oben	upper lever	levier superieur	leva superiore
3	20938500	2	Scheibe 21x37x3	washer	Rondelle	rondella
5	20797800	4	Bolzen mit Kopf Ø12x20x25	bolt	Boulon	bullone
6	20622600	19	Scheibe 13,0x24,0x2,5 PA	washer	Rondelle	rondella
7	21464900	1	Gleitplatte	sliding plate	plaque coulissante	piastra scorrevole
8	21164802	1	Hebel	lever	levier	leva
9	20797800	1	Bolzen mit Kopf Ø12x20x25	bolt	Boulon	bullone
10	20373800	4	SL-Sicherung 12	safety piece	Collier d'épaulement	pezzo di sicurezza
11	21164700	1	Zwischenhebel	lever	levier	leva
12	21164500	1	Betätigungshebel innen	inner lever	levier intérieur	leva dentro
13	21165401	1	Betätigungshebel aussen	external lever	levier extérieur	leva di fuori
14	20195300	2	Verbusschraube M8x20 Zn	hex.head screw	Vis à tête hex.	vite a testa esagonale
15	20359500	1	Abdeckkappe schwarz	cover	Capot	tappo
16	20985800	1	Flachkappe 4,9x24x109,6	lever sheathing	Revêtement	ricoprimento
17	21164902	1	Federachse	slide axle	axe chariot	asse slitta
18	21176600	1	Distanzbuchse 8,5x12x26,5	distance bush	manchon d'espacement	distanziale
19	20067600	5	Scheibe 8,4x17x1,6	washer	Rondelle	rondella
20	20032400	1	Zylinderschraube M8x60 VA	cylindrical-head screw	Vis cylindrique	vite a testa cilindrica
21	21207302	1	Federrohr	tube	tube	tubo
22	21246100	1	Druckfeder VD-328	tension spring	ressort à pression	molla di pressione
23	21246300	1	Distanzbuchse 13x16x88	distance bush	manchon d'espacement	distanziale
24	21165100	2	Federbuchse	spring bushing	douille	bussola
25	20801400	2	Sicherungsring I40 VA	circlip	Circlips	anello di sicurezza
26	20656300	1	6-Kantmutter M 12 stopp	hex.nut	écrou hexagonal	dado esagonale
27	21341001	1	Wandhebel	lever	levier	leva
28	21164003	1	Düsenhalter vorn	support	support	supporto
29	20280500	4	6-Kantmutter M 8 STOPP VA	hex. Nut	Ecrou	dado essag.
30	21252801	1	Düsenhalter hinten	support	support	supporto
31	20585500	1	Sterngriffschraube M8x55	star wheel screw	Vis avec poignée étoile	vite con manopola a stella
32	20277800	2	Scheibe 9,0x28,0x3 VA	washer	Rondelle	rondella
33	20619900	2	Distanzbuchse 12x8,0x7,5	distance bush	manchon d'espacement	distanziale
34	20856100	1	Druckfeder VD-207KA VA	compression spring	Ressort de compression	molla di compressione
35	21024300	2	Abweisrolle	protecting caster	Roulette de protection	ruota di protezione
36	20076400	2	Scheibe 4,3x12,0x1 Ms	washer	Rondelle	rondella
37	20159300	2	Linsenschraube M 4x 6 VA	lens screw	Vis à tête bombée	vite a testa lenticolare
38	20633700	1	Scheibe 8,4x24,0x2 VA	washer	Rondelle	rondella
39	20000500	1	6-Kantmutter M 8 Zn	hex. Nut	Ecrou	dado essag.
40	20085500	1	Scheibe 13,0x37,0x3,0 VA	washer	Rondelle	rondella

Gerätedüse

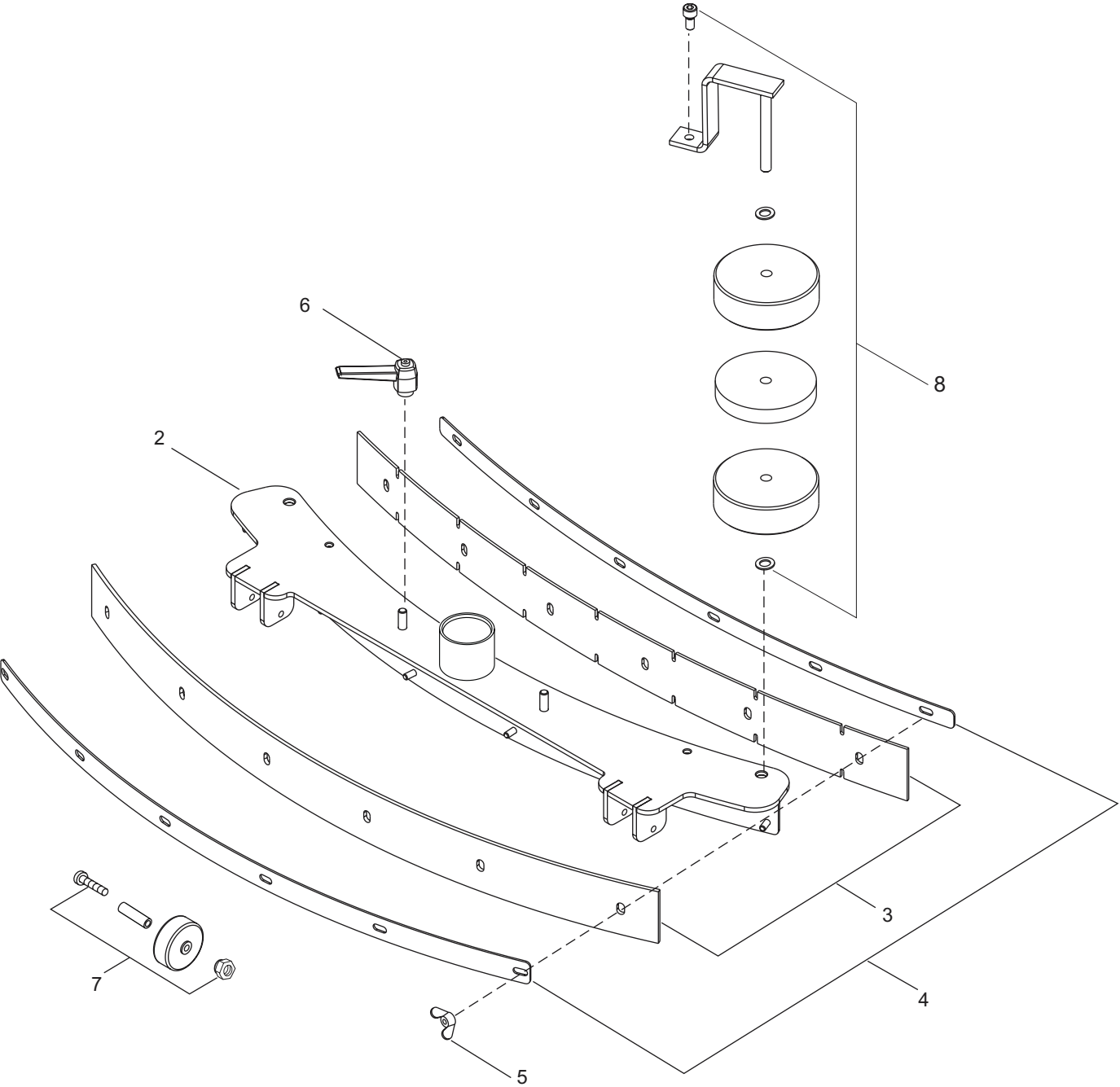

Gerätedüse

Pos.	Art.Nr.	Stück	Bezeichnung	Description	Designation	Descrizione
	20623731		Gerätedüse kpl. 66	Squeegee tool cpl. 66	Buse d'aspiration compl.66	bocchetta compl. 66
2	20618902	1	Gerätedüse 66	squeegee tool 66	Buse d'aspiration 66	bocchetta 66
3	20620031	1	Sauglippen Satz 66	squeegee blades set 66	Set raclette 66	set lamelle 66
	20620032		Sauglippen Satz 66 ölbeständig	squeegee blades set 66	Set raclette 66	set lamelle 66
4	20620230	1	Klemmleiste Satz 66	clamping strip set 66	Fixation (set) 66	set plattina bloccagomma 66
5	20623130	1	Flügelmutter Set (12 Stück)	nut set (12 pieces)	Ecrou (set-12 pieces)	set dado a farfalla
6	20783230	1	Klemmhebel Set (2 Stück)	clamping lever set (2 pieces)	Levier pour fixation (set)	set lavetta di fissaggio
7	20442433	2	Gummirolle	guide roll	Rouleau d'appui	ruota
8	20621430	2	Abweisrolle hoch BG	high protecting caster assy	Roulette de protection	ruota di protezione

Chemiedosierung

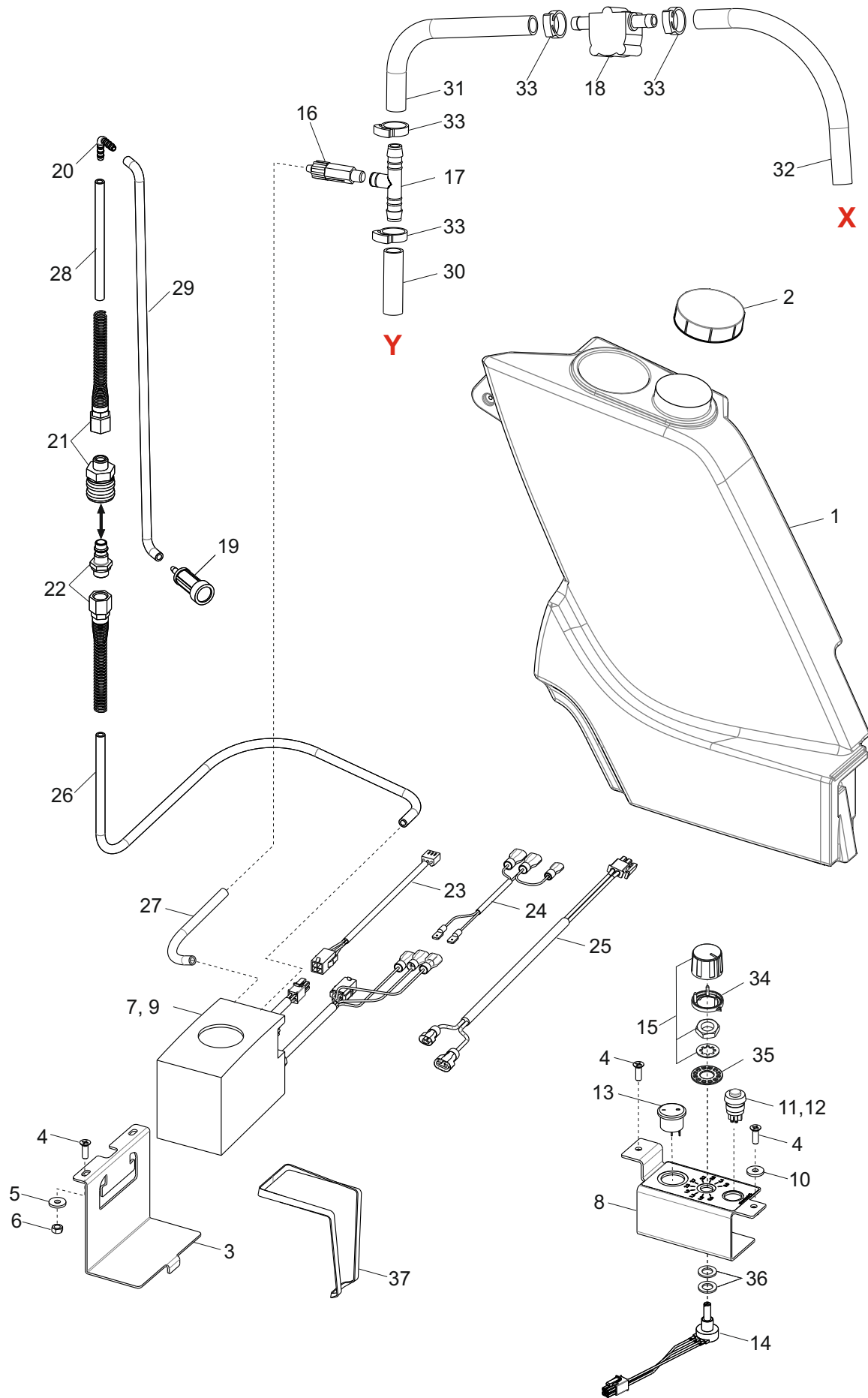

Chemiedosierung

Pos.	Art.Nr.	Stück	Bezeichnung	Description	Designation	Descrizione
1	21460900	1	Seitenteil rechts	side part right	pièce latérale gauche	parte laterale destra
2	21173700	1	Schraubdeckel Chemietank	screwed lid	Couvercle vissée	coperchio filettato
3	21261501	1	Halter Chemiepumpe	Bracket for pump	Support	supporto
4	20086500	4	Senkschraube M 5x16 VA	countersunk screw	Vis à tête noyée	vite a testa svasata
5	20067600	3	Scheibe 8,4x16,0x1,6 VA	cilindrical-head scr.	Vis cylindrique	vite a testa cilindrica
6	20574300	2	6-Kantmutter M5 VA	hex. Nut	Ecrou	dado essag.
7	20970600	1	Chemie-Pumpe C0059-1 mit	pump for chemistry	Pompe pour la chimie	pompa per la chimica
8	21261401	1	Halter Bedienelemente	plate for switches	Support	supporto
	70108300	1	Aufkleber Chemiedosierung	label	Autocollant	etichetta
9	20970601	1	Schlauch mit Halter	hose	Tuyau	tubo flessibile
10	20067600	1	Scheibe 8,4x16,0x1,6 VA	cylindrical-head scr.	Vis cylindrique	vite a testa cilindrica
11	20369100	1	Druckknopfschalter	push-button switch	Commutateur	interruttore a pulsanze
12	20616000	1	Schutzkappe	protection cap	Capuchon de protection	coperchio di protezione
13	21044000	1	Wippschalter rund Ein-Aus	switch	Interrupteur	interruttore
14	21168730	1	Potentiometer 100KOhm	potentiometer	Potentiomètre	potenziometro
15	21168830	1	Potentiometerknopf	potentiometer button	bouton potentiomètre	bottone potenziometro
16	20970800	1	Rückschlagventil Chemie	retention valve	valve de retenue	valvola antiritorno
17	21047300	1	T-Stück 12	hose nozzle	Tubulure fileté	beccocio tubo flessib.
18	20970700	1	Durchlaufmesser	flow indicator	débitmètre	flussometro
19	20405300	1	Filter	filter	filtre	filtro
20	21041800	1	Verbindungsstutzen	hose nozzle	Tubulure fileté	beccocio tubo flessib.
21	21264600	1	Kupplung mit Feder NW5	quick coupling	Couplage	accoppiamento
22	21264700	1	Nippel mit Feder NW5	plug-in coupling	Nipple	nipplo
23	21041402	1	Kabel Pumpe-Durchlaufmesser	cable	Câble	cavo
24	21069900	1	Kabel Chemie-Pumpe	cable	Câble	cavo
25	21262101	1	Anschlussleitung Chemie-Pumpe	cable	Câble	cavo
26	50986300	0,6m	PVC-Schlauch transp. 5x1,5	hose	Tuyau	tubo flessibile
27	50986300	0,420 m	PVC-Schlauch transp. 5x1,5	hose	Tuyau	tubo flessibile
28	50986300	0,120 m	PVC-Schlauch transp. 5x1,5	hose	Tuyau	tubo flessibile
29	50986300	0,500 m	PVC-Schlauch transp. 5x1,5	hose	Tuyau	tubo flessibile
30	50680800	0,070 m	PVC-Gewebeschlauch D13x3	hose	Tuyau	tubo flessibile
31	50020600	0,3m	Schlauch m.Drahtspirale Ø13x3	hose	Tuyau	tubo flessibile
32	50020600	0,4m	Schlauch m.Drahtspirale Ø13x3	hose	Tuyau	tubo flessibile
33	20596500	4	Schlauchklemme D17-18,5	hose clamp	Collier	fascetta tubo flessib.
34	21342000	1	Rastfeder	washer	Rondelle	rondella
35	21341900	1	Rastscheibe	washer	Rondelle	rondella
36	20054500	2	Scheibe 10x16x1	washer	Rondelle	rondella
37	21464500	1	Gummiring	rubber ring	caoutchouc	elastico

Wasserführung

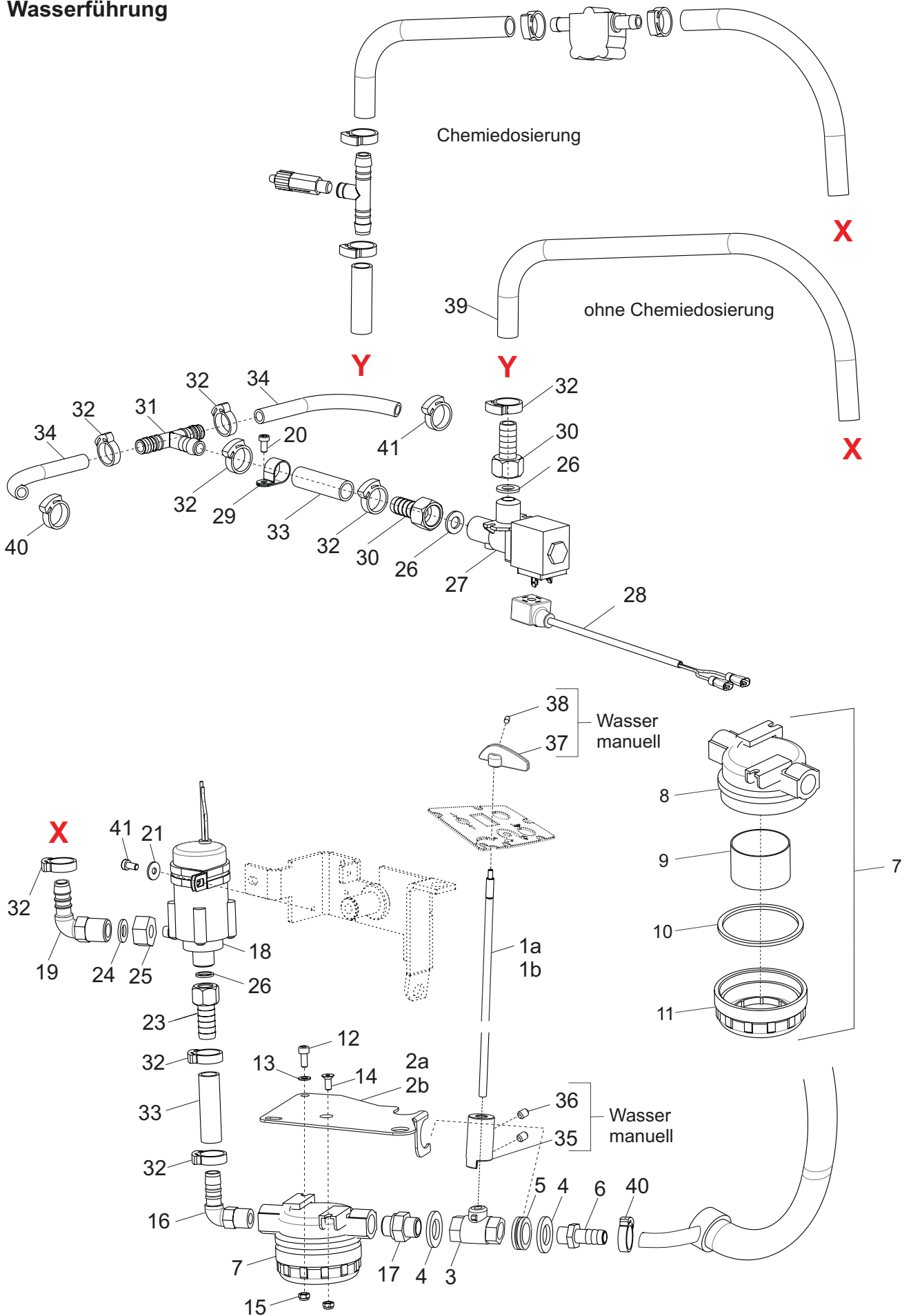

Wasserführung

Pos.	Art.Nr.	Stück	Bezeichnung	Description	Designation	Descrizione
1a	21177100	1	Stange (Wasser manuell)	bar	tige	asta
1b	21416600		Stange (Wasser elektr.)			
2a	21416701	1	Ventilhalter (Wasser man.)	valve holder	support pour valve	supporto valvola
2b	21416700		Ventilhalter (Wasser elektr.)			
3	21033200	1	Kugelhahn 3/8"-D10 Ms/Ni	ball valve	robinet à bille	robinetto
4	20627500	2	Scheibe 17,0x30,0x3 PA	washer	Rondelle	rondella
5	20931000	1	Durchführungsstülle	gasket	garniture	guarnizione
6	20681400	1	Schlauchtülle 3/8"	hose nozzle	Tubulure filetée	beccuccio tubo flessib.
7	20760700	1	Filter Inline 3/8" Innengewinde	filter	Filtre	filtro
8	20866100	1	Grundkörper	base body	base corps	sostanza fondamentale
9	20815700	1	Filtereinsatz	filter insert	cartouche filtrante	cartuccia del filtro
10	21158700	1	Formdichtung Inline-Filter	gasket	Garniture	guarnizione
11	20815800	1	Schraubkappe für Filter	screwed cover	Calotte vissée	cappello filettato
12	20149200	1	Zylinderschraube M 5x12 VA	cylindrical-head scr.	Vis cylindrique	vite a testa cilindrica
13	20009600	1	Scheibe 5,3x10,0x1,0 Zn	washer	Rondelle	rondella
14	20002800	1	Senkschraube M 5x12 VA	countersunk screw	Vis à tête noyée	vite a testa svasata
15	20280600	2	6-Kantmutter M 5 STOPP VA	hex. Nut	Ecrou	dado essag.
16	20671000	1	Winkel-Einschraubstutzen	hose nozzle	Tubulure équerre filetée	beccuccio tubo flessibile
17	20105800	1	Doppelgewindenippel	threaded nipple	Raccord filetée	raccordo filettato
18	21054931	1	FW-Pumpe mit Halter	fresh water pump	Pompe eau propre	Pompa
19	20805300	1	Winkel-Einschraubtülle	grommet	Douille	passacavo
20	20730900	1	Zylinderschraube M 5x10 VA	cylindrical-head scr.	Vis cylindrique	vite a testa cilindrica
21	20183000	1	Scheibe 5,3x15,0x1,4 V2A	washer	Rondelle	rondella
22	20556000	2	Flachsteckhülse 6,3 vollis	blade receptacle	clip pour languette de raccordement	bossolo
23	21246700	1	Gewindetülle G3/8"LW13 PA	nozzle	Tubulure filetée	beccuccio
24	20107300	1	Dichtung D11/D14,7x1,5	seal	Rondelle d'étanchéité	anello di tenuta
25	21073200	1	6-Kt Mutter G1/2"	hex.nut	Ecrou hexagonal	dado
26	21073600	3	Dichtring D10xD19x2	sealing ring	Rondelle d'étanchéité	garnizione
27	21055000	1	Magnetventil	magnetic valve	Electrovalve	elettrovalvola
28	21055011	1	Gerätestecker Magnetv.55	appliance plug	Prise	spina elettrovalvola
29	21341500	1	Rohrschelle RSGU1 16/12 W1	pipe clamp	bride d'attache	staffa per tubi
30	21061100	2	Gewindetülle G1/2" LW13 PA	nozzle	Tubulure filetée	beccuccio
31	21047302	1	T-Stück 12 2x G1/4	T-piece	raccord en T	raccordo a T
32	20596500	8	Schlauchklemme D17-18,5	hose clamp	Collier	fascetta tubo flessib.
33	50680800	2	PVC-Gewebeschlauch D13x3x1	hose	Tuyau	tubo flessibile
34	50660300	2	PVC-Gewebeschlauch D10x3	hose	Tuyau	tubo flessibile
35	21033303	1	Kupplung mit Anschlag	attachment	Couplage	giunto
36	20404000	2	Gewindestift M6x8	headless screw	Goupille filetée	spina filetata
37	20647100	1	Zeigerknopf f. Wasserdos.	index button	Boutton	manopola indicatore
38	20927800	1	Gewindestift M5x8 VA	headless screw	Goupille filetée	spina filetata
39	50020600	1	Schlauch 13x3x0,8m	hose	Tuyau	tubo flessibile
40	20628400	2	Schlauchklemme 15-17,2	hose clamp	Collier	fascetta tubo flessib.
41	20030400	1	Zylinderschraube M 5x45 VA	cylindrical-head scr.	Vis cylindrique	vite a testa cilindrica

Security Kit optional

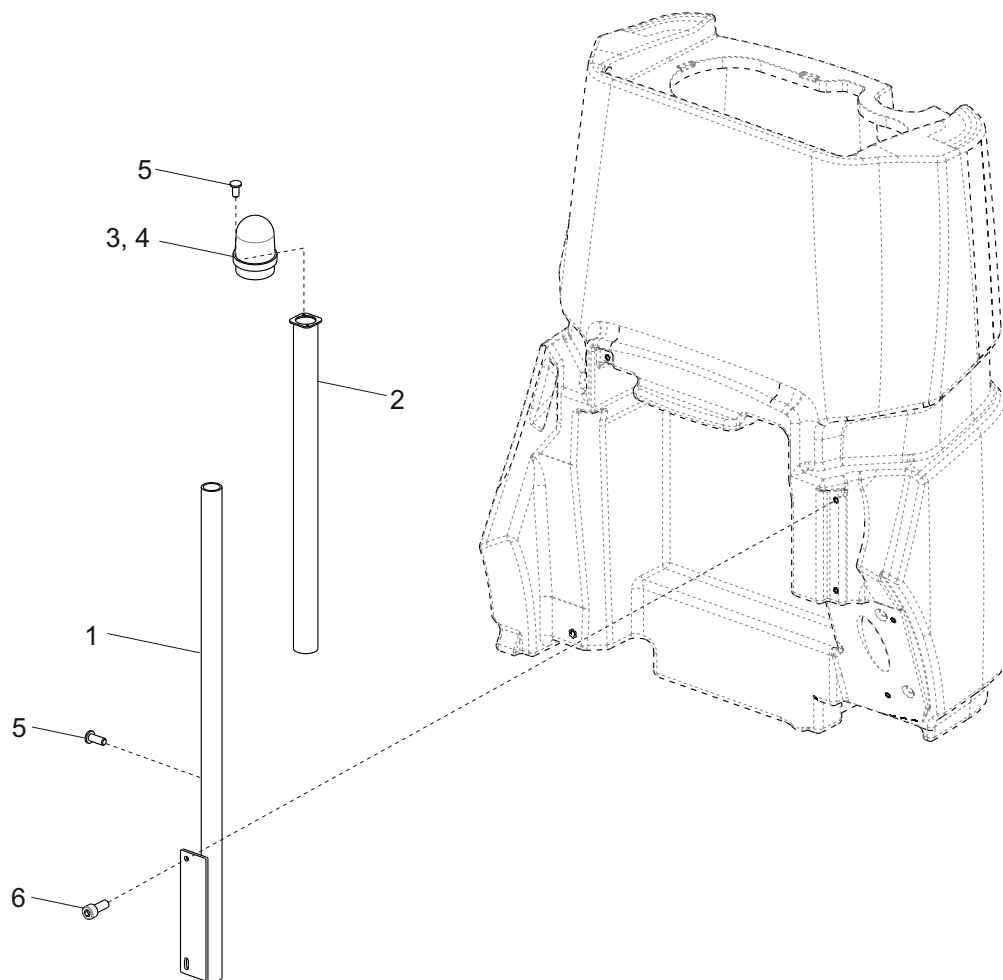

Pos.	Art.Nr.	Stück	Bezeichnung	Description	Designation	Descrizione
1	21462200	1	Lichtstange unten	lower light bar	barre lumineuse	barra luminosa
2	21174900	1	Lichtstange oben	upper light bar	barre lumineuse	barra luminosa
3	20673000	1	Rundumleuchte B15d	flash light	lumière du flash	flash di luce
4	20672900	1	Glühlampe BA15d 24V/7W	incandescent lamp	Lampe à incandescence	lampada ad incandescenza
5	20010800	3	Linsenschraube M 4x 8 VA	lens screw	Vis à tête bombée	vite a testa lenticolare
6	20279200	2	Zylinderschraube M 6x16 VA	cylindrical-head screw	Vis cylindrique	vite a testa cilindrica
7	21347801		Piezo-Buzzer	horn	Claxon	clacson

Änderungen im Zuge technischer Verbesserungen sind vorbehalten !
We reserve the right to effect modifications within the framework of technical progress !
Sous réserve de modification dans le cadre des développements techniques !
Essendo la nostra un'impresa a carattere innovativo, ci riserviamo la possibilità di apportare modifiche tecniche !

G. Staehle GmbH u. Co. KG
columbus Reinigungsmaschinen
Postfach 50 09 60
70399 STUTTGART
Telefon +49(0)711 / 9544-950
Telefax +49(0)711 / 9544-941

info@columbus-clean.com
www.columbus-clean.com

CLEAN IS QUALITY **columbus**

70123300