

UPT 250

One-man operation mounting device - ideal for glass, steel and other smooth material

UPT 250

Order No.: 106498

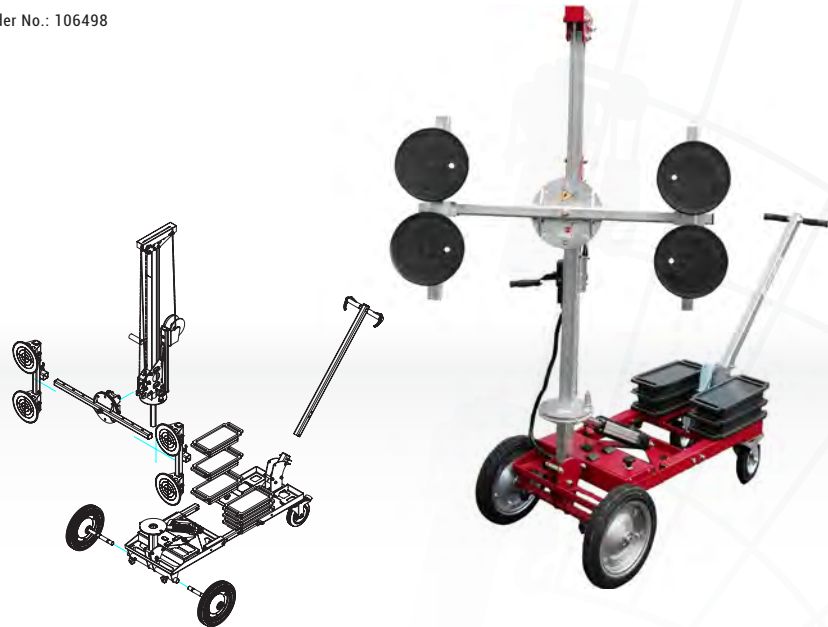

- » Raises, lowers and tilts elements up to 250 kg
- » Uncomplicated and fast setup
- » Total width from 680 mm to 910 mm (without vacuum system)
- » Stroke approx. 1,000 mm
- » Rotates elements up to 2.5 m in length
- » Mast swivelable by $\pm 90^\circ$
- » Mast tiltable by $+7^\circ / -30^\circ$
- » Suction unit rotatable 360°
- » Non-slip handles

TECHNICAL DATA	
Bearing capacity	250 kg
Vacuum cups	4 hand lifting units (ø 230 mm)
Weight	265 kg
Tare weight	130 kg without counterweights
Drive	Manual / Mast tilting electric with integrated battery and charger
Handle	Non-slip handles
Tires	PU-tires (ø 350 mm)
Others	Can be disassembled without tools
Optional	Side offset; Crane attachment; Suction surface enlargemen; Attachment of forklift tines; Electric winch

Dimensions

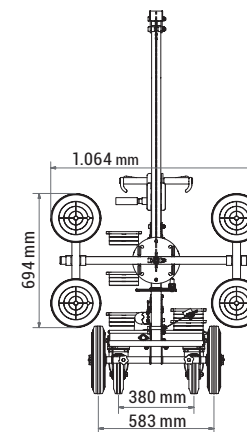
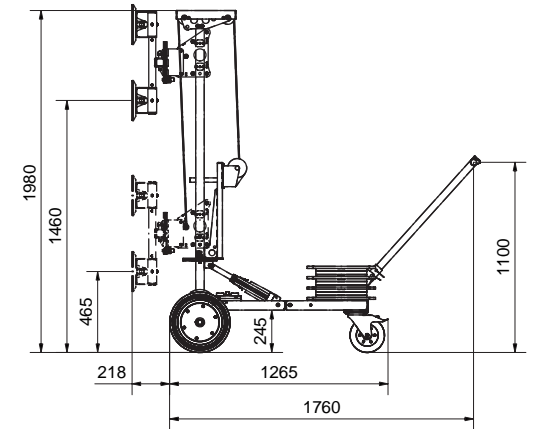
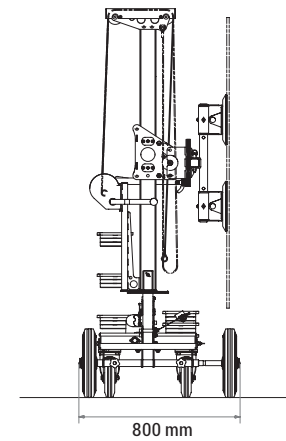

Tilt

