

# **DURO** **TANK**<sup>®</sup>

*'BUILT TOUGH, PROVEN TOUGH'*



**Poly Diesel**  
**2,400L**

**SPEC SHEET**

Size	Safe Fill (L)	Weight (kg)	Length (mm)	Width (mm)	Height (mm)
2,400L	2,400	850	4500	2000	1900

### Standard Features:

- Designed and manufactured in Australia to Australian Standards
- Diesel grade Polyethylene tank with ball baffle system to ensure stability of liquid
- Dual Axle
- Spare Wheel, mount to front of trailer, pumps and accessories at rear of trailer
- Safety signage for Australian regulations
- Rubber Torison Suspension - which is maintenance free
- 5x new 16" Wheel
- Electric Brakes with brake safe unit
- 4.5kg Fire Extinguisher
- LED Lights

### Optional Pumps:

- 12v/24v Pump (with or without Solar Battery kit)
- Diesel or Petrol Driven Pumps

### Optional Accessories:

- 10m, 20m or 30m Heavy Duty Retractable Hose Reel
- 1-10m Loose Hose
- Emergency Stop, Battery Isolator, Wheel Chocks, Wheel Nut Indicators and Reflective Mine Tape
- LED Work Light Kits
- Fuel Management Systems
- Reconnectable Breakaway Coupling
- Auto Shutoff Nozzle
- Wiggins Nozzle
- Lockable pump cabinet with gas struts





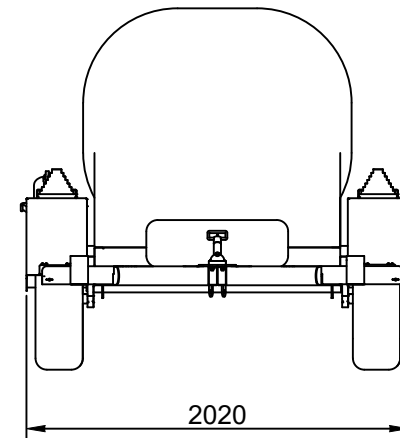
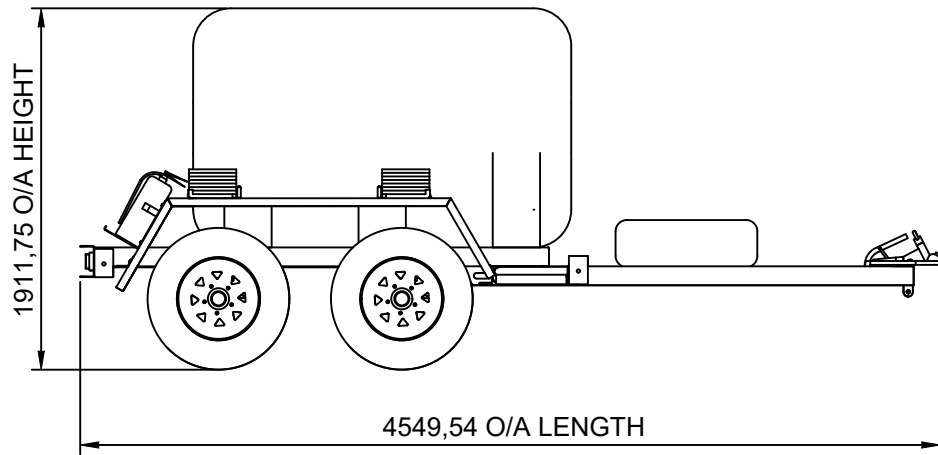
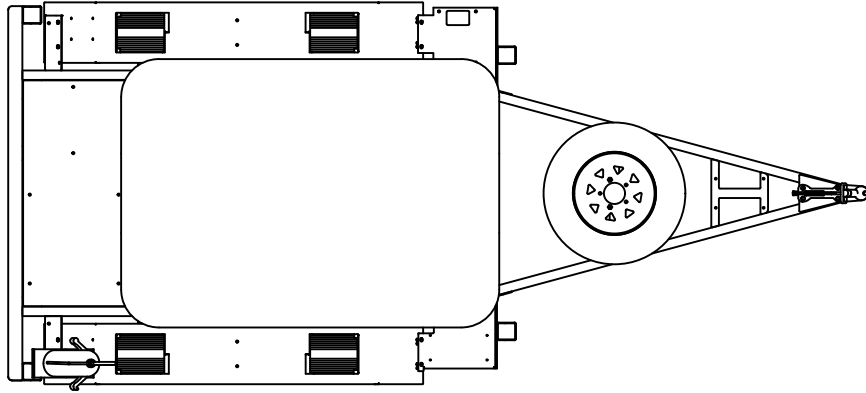

- GENERAL NOTES**
- ALL DIMENSIONS ARE IN MILLIMETERS (mm) U.N.O
  - GENERAL TOLERANCE U.N.O
    - X ± 0.5
    - XX ± 0.1
    - XXX ± 0.05
    - Angular ±0.25°
  - REMOVE ALL SHARP EDGES AND BURRS
  - PAINTING MANUFACTURER IN ACCORDANCE
  - MATERIAL GR250

REV	DATE	DETAILS	BY/APPD
A			
REVISION HISTORY			

**DURO**  
**TANK**  
DURABILITY BUILT TO LAST

114-116 Canada St, Lake Cargelligo NSW 2672  
Phone: 1300 829 802  
Fax: 1300 259 659

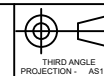

THIRD ANGLE  
PROJECTION - AS1100



STANDARD FINISH  
SURFACE

CHK: DATE: 00/00/2018  
DRN: MWH DATE: 11.09.2018

TITLE  
**2,500L TRAILER**

SHEET NO: **A4**  
DWG NO: PTRW025  
DO NOT SCALE U.N.O PAGE 02 OF 02

MASS: N/A