

Melt Pressure Transmitter

Model: PT124G-123T (High precision)



Description

PT124G-123T Series Melt Pressure Transducer (Flexible stem & High accuracy) with thermocouple which can measure the pressure and temperature in one point , This series adopts special construction and excellent alloy elastic membrane to reduce the thermal draft and improve the accuracy. Zero & full span can be adjustable, amplified signal can be connected with PLC, which is the international standard. It is suitable for pressure measuring and controlling in melt fluid medium, such as the plastic & polymer in the process equipments. Can replace Dynisco / Gefran /GP50 etc. international brand absolutely .

Application

- ◆ Chemical fiber & spinning Equipment
- ◆ Plastic and rubber, polyester process equipment
- ◆ Other pressure measurement and Control

Feature

- ◆ High-standard quality , High accuracy
- ◆ Stainless steel Seal
- ◆ Simple Installation
- ◆ Completely interchange similar import products
- ◆ Internal 80% calibration
- ◆ Excellent stability
- ◆ Can measure the pressure and temperature in one point



Dimension

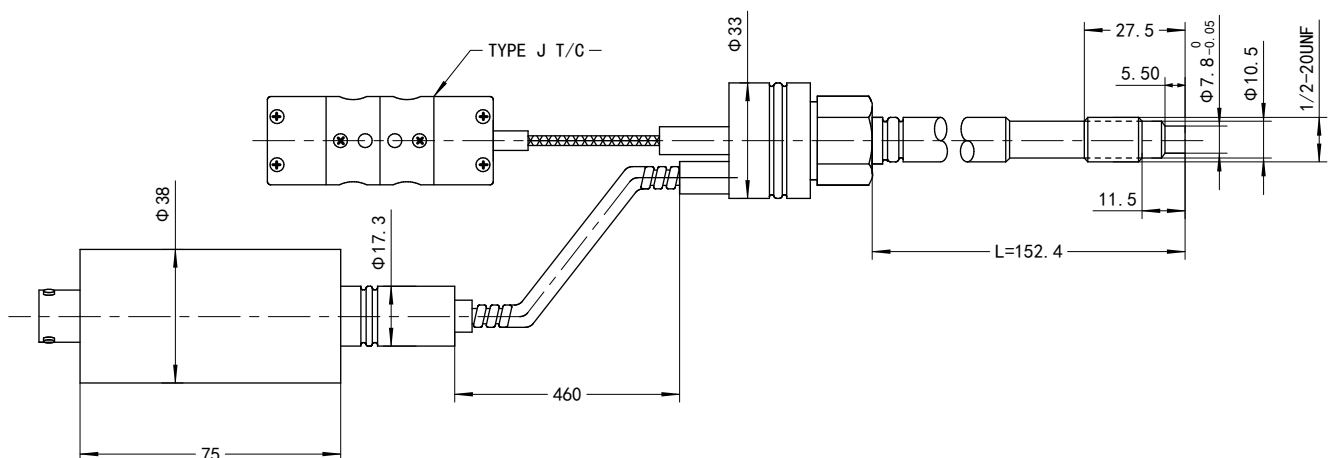

Specification

Pressure range:	0...3.5 MPa to 0...150MPa
Output:	2mV/V; 3.33mV/V
Input voltage:	10VDC
Accuracy:	±0.25FSO ; ±0.5%FS (including linearity , Repeatability & Hysteresis)
Repeatability:	±0.2% FSO
Construction:	Wheatstone bridge
Bridge resistance:	Input: 345 Ohms Minimum; Output: 350 Ohms±10%
Overload pressure:	1.5×FSO
Internal shunt calibration:	80%±1%
Insulation Resistance:	200Megohms @100Vdc
Standard wetted Parts	Diaphragm coated 15-5PH SST
Mounting Torque	500inch/lbs , maximum
Max. Diaphragm Temp:	0~400°C
Electronic operating temperature:	-25°C -85°C
Electric connector:	5PIN;6PIN
Rigid Length:	6",9" (Customer design)
Flexible Length:	18" , 30" (Customer design)
Thermocouple type:	J,K,E,PT100 Optional
Process connection:	1/2"-20UNF, M14×1.5, M18×1.5 (Customer design)

Mounting Hole

<p>Planar Sealed</p>	D1	M22×1.5	M28×1.5	G3/4"	PT3/8"
	D2	Φ16.1	Φ18.3	Φ18.3	Φ10.3
	D3	Φ20.1	Φ26.1	Φ24.2	Φ14.9
	M	Φ23	Φ30	Φ21	Φ11
	A	11	12	12	14
	B	12	15	15	19
	C	40	35	35	40
<p>45° Slope Sealed</p>	D1	M12×1.5	M14×1.5	1/2-20UNF	M18×1.5
	D2	Φ8	Φ8	Φ8	Φ10.1
	D3	Φ10.8	Φ12.5	Φ11.5	Φ16.1
	D4	Φ12.5	Φ14.5	Φ13.1	Φ20
	A	6	6	6	6.5
	B	9	9.5	9.5	10

Ordering Guide

Model	Range (bar)	Output	Rigid & flexible length (inch)	Screw Thread	Electric connection	Accuracy	Thermo Type	Others
PT124G-123T	---	---	---	---	---	---		---

Example: PT124G-123T-500Bar-3.33mV/V -6/18"-1/2-20UNF-6PIN-0.5%FS-J

Attention for installation

1, Installation

Do not remove protective cap until ready to install. Prior to initial installation, verify correct machining of mounting hole. Install with aluminum gasket. The electronics housing should be secured, with the enclosed mounting bracket.

2, Remove

Make sure that there is no remained metal or plastic; remove all of the transducers from the equipment before you clean the extruder. You can remove the transducer only when the polymer is molten. And clean the diaphragm of the transducer with soft cloth as soon as you remove it. At the same time, you can use ZHYQ's cleaning tool kit to clean the remained material in the mounting hole in order to install easily next time.

3, Start-up

Bring system to operating temperature, and with no pressure, follow recommended procedures with instrumentation for zero and span adjustment. Make sure that there is sufficient "soak time" to assure that any material at the tip of the transducer is molten before process is started.

4, Electrical house

The tip of the transducer can endure high temperature, but the shell (electrical house) only endure temperature lower than 80°C, so it should place in the room temperature. It can benefit for the accuracy and natural life of the transducer if you keep the shell from the high temperature.

5, Overload effect

During the course of pressure measuring and controlling, it is better to make sure the transducer within the rated pressure, too long time overload the pressure will affect the accuracy and natural life of transducer, although the transducer own determinate overload ability.

6, Wiring

Use shielded cable, attach cable shield to ground at one end only. In order to prevent the jamming.

Select correct installation

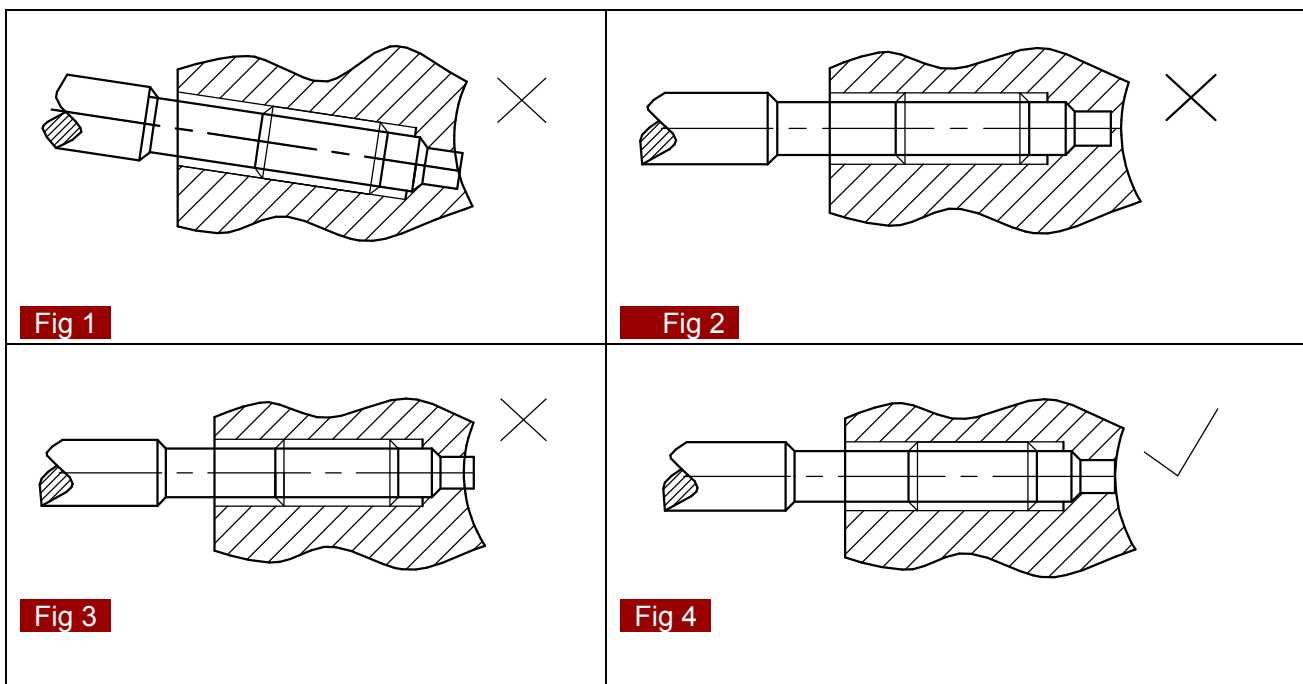

Wiring diagram

Output	Function	Color	5PIN	
2mV/V; 3.3mV/V; 3.33mV/V;	Signal +	Blue	1	
	Excitation +	Red	2	
	Signal -	White	3	
	Excitation -	Yellow	4	
	Calibration	Black	5	
Output	Function	Color	6PIN	
2mV/V; 3.3mV/V; 3.33mV/V;	Signal +	Blue	A	
	Signal -	Green	B	
	Excitation +	Red	C	
	Excitation -	Yellow	D	
	Calibration	Brown	E	
	Calibration	Black	F	

Shanghai Zhaohui Pressure Apparatus Co., Ltd

5-6F No.8 Building No.115 ,Lane 1276 Nanle Road Songjiang District Shanghai 201600 China
 Tel:+86-21-51691919 67755189 Fax:+86-21-67755185
 E-mail: info@zhyqsensor.com
www.zhyqsensor.com

