

# MODEL RANGE

FH13 6x4 Tractor Leaf Suspension FH 64T 3L

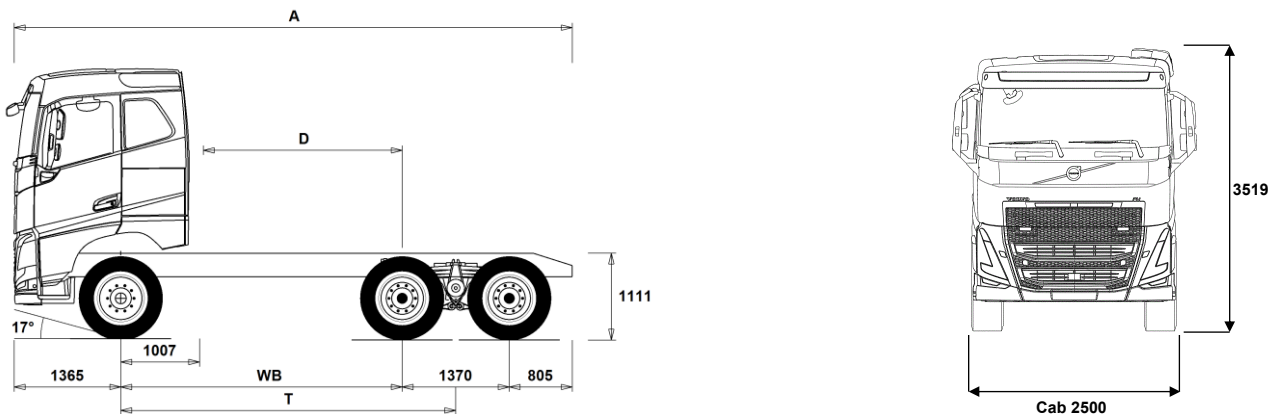

## Chassis Dimensions [mm]

<b>WB Wheelbase</b>	<b>3600</b>
A Overall Chassis Length	7140
D Center of rear axle to back of cab	2543
T Theoretical Wheelbase	4285

## Chassis Weights [kg]

Front Axle	5030
Rear Bogie	3835
Kerb Weight	8865

## Turning Diameter [mm]

Turning Circle Diameter Kerb to Kerb	15100
Turning Circle Diameter Wall to Wall	16500

## Plated Weights [kg]

	Plated	Design
Gross Vehicle Weight	23000	28100
Gross Combination Weight	42500	44000
Front Axle	6500	7100
Rear Bogie	16500	21000

## Important Notes

### Chassis Dimensions

Cab Height: +305 mm for CAB-HSLP, -285 mm for CAB-LSLP, +450 mm for CAB-XHSL.

Front Axle to Back of Cab: +74 mm for CAB-LSLP.

D-measure includes a front clearance of 50 mm and for rigid trucks also a subframe of 100 mm.

Height can vary ± 20 mm for leaf and ± 10 mm for air suspension.

All dimensions are for unladen chassis and any tag axles down.

Weight and dimensions are based upon the following tyres:

Front Axle Tyres: 315/80R22.5  
 Drive Axle Tyres: 315/80R22.5

**Chassis weight includes oil, water, AdBlue, 0 litres fuel and without driver. Kerb weight can vary ± 3%.**

Turning diameters are theoretically calculated.

Legal weights can differ from country to country.

For more detailed weight information, including optional equipment weights, ask your Volvo sales contact to enter your specification into the Volvo Weight Information system (WIS).

Do NOT use this drawing for bodybuilding. Refer to Volvo Bodybuilder Instructions and chassis assembly drawing FH64T3L.

# MODEL RANGE

## FH13 6x4 Tractor Leaf Suspension FH 64T 3L

### Truck use

- **RC-ROUGH** Operating class on/off road

### Core components

- **CHH-HIGH** Chassis Height High approx. 1025-1050mm (depending on tyre selection)
- **RADD-BR** Parabolic spring rear leaf suspension
- **FH-LSLP6** Low Sleeper Cab
- **FH-SLP6** Sleeper Cab
- **FH-XHSL6** Globetrotter XL Cab
- **EU6SCR** Eu6 SCR (Particulate Filter & EGR) Single Stage Turbo
- **D13S500A** Eu6 Fuelface 13 litre Engine 500hp/2500Nm/368kW
- **D13S540A** Eu6 Fuelface 13 litre Engine 540hp/2600Nm/397kW
- **D13K500** Eu6 13 litre Engine 500hp/2500nm/368kW
- **D13K540** Eu6 13 litre Engine 540hp/2600nm/397kW
- **EBR-VEB+** Volvo Engine Brake + (VEB+)
- **AT2612** Volvo I-shift 12 Speed Automatic Transmission (2600nm)
- **ASO-C** Crawler Gears
- **ASO-ULC** Ultra Low Crawler Gears
- **RTH2610B** Volvo RTH2610B hub reduction rear axles  
4 planet gears per hub  
Axle rating: 26,000 kg  
115 tonne train weight  
(Application approved)
- **RTS2310A** Single Reduction Tandem 23t GCW100t
- **RTS2370B** Single Reduction Tandem 23t GCW70t

### Packages

- **INFOHIGH** High Level Information Platform

### Chassis

- **FST-PAR** Parabolic leaf spring front suspension
- **FST-PAR3** 3 Leaf Parabolic Front Springs (stiffer than normal)
- **FAL7.1** Front Axle Load 7.1 tonnes
- **FAL7.5** Front Axle Load 7.5 tonnes
- **FSTAB** Front stabilizer, normal stiffness
- **FSTAB2** Front stabiliser bar increased stiffness
- **FSTAB3** Heavy duty front stabiliser bar
- **RAL21** Rear suspension load rating: 21,000 kg
- **ACTST-TO** Volvo Dynamic Steering
- **ASFE-PO** Dynamic Steering Active Features - Personal Settings & Oversteer Guidance
- **ASFE-PS** Dynamic Steering Active Features - Personal Settings
- **PSP-VAR2** Power Steering Pump with Electronic Control Variable Displacement
- **EBS-MED** Electronic Brake System (EBS) contains ABS, Traction control, Hill start aid  
Diff lock control, Brake assist  
Wheel brake monitoring, EBS status
- **RST-PAR1** Parabolic leaf spring rear suspension
- **FRAME300** Frame rail height 300mm
- **FST7070** Frame Section Thickness 7mm
- **FST8080** Frame Section Thickness 8mm
- **FIL-TXEB** Liner (inner) - trans x-mem to end of bogie
- **BBOX-L** Battery box mounted on LHS chassis rail
- **BATS-S** Battery system - single
- **2BATT225** 2x225 Ah batteries
- **BATTAMP** Battery Amperage Indicator (in the DID)
- **MSWI-C** Isolation Toggle Switch LHS of Chassis
- **MSWI-R** Isolation Switch on Key Fob (Press Door Lock Twice to Isolate)

■ Standard Equipment

□ Optional Equipment

For more detailed information about cab and powertrain equipment, please refer to separate specification sheets.

For all possible options and combinations of options please consult your Volvo sales contact who can create a specification to match your requirements using the Volvo Sales Support system (VSS).

The factory reserves the right to modify design and change equipment without previous notification. The specification can vary from country to country.

- **R465A71** RHS 465 litre alloy fuel tank  
Min volume 465l  
Max volume 465l
- **UL-FUEL** LHS fuel tank not fitted
- **ADTP-L** AdBlue Tank Position - LHS
- **ADB090** AdBlue Tank 90 litres
- **FCAP-L** Fuel Tank Cap with Lock
- **ESH-RIGH** Muffler horizontal, right exhaust outlet
- **ESH-VERT** Muffler horizontal, vertical exhaust outlet on right hand side
- **EXST-SSP** Stainless Steel Exhaust Stack
- **TOWF-NO1** One Towing Device - Front
- **TBC-AUS** Trailer Brake Connections - Suzi Coils
- **TRBR-HCR** Hand controlled trailer brake, reduced pressure
- **TRBR-STA** Stationary Trailer Brake Control
- **TRB-STRE** Automatic Trailer Brake Activation (Stretch Brake)
- **RFEND-H2** FH 84T coloured guards need to be added via Free Text CA due to the fact that second steer single guard has to be included as well
- **TL-LED** LED Tail Lights
- **BLIGHT-E** Emergency Brake Lights

### Rims and Tyres

- **RT-AL** 10 Stud Alloy Disc Rims (with long wheel studs)
- **RT-AL1** 10 Stud Alloy Level 1 Disc Rims (with long wheel studs)
- **RT-AL1DU** 10 Stud Alloy Level 1 Disc Rims (with short wheel studs)
- **RT-ALDP** 10 Stud Dura-Bright Alloy Disc Rims (with long wheel studs)
- **RT-ALDPD** 10 Stud Dura-Bright Alloy Disc Rims (with short wheel studs)
- **RT-ALDU** 10 Stud Alloy Disc Rims (with short wheel studs)
- **RT-STEEL** 10 Stud Steel Disc Rims
- **SPWT-D** Spare rim & tyre equal to drive
- **SPWT-F** Spare rim & tyre equal to steer
- **SWCP-T2** Transport Mounted Spare Wheel
- **JACK-15T** 15 tonne capacity jack and brace
- **TOOL-BAS** Basic tools
- **TOOLKIT** Tool kit complete
- **INFLAHOS** Tyre inflation hose (18 metres)
- **OBDEP-D**

### Powertrain equipment

- **TRAP-HD** Heavy Duty Transmission Internals
- **DRM-BE** Drive Mode - Balanced & Economy
- **DRM-E** Drive Mode - Economy
- **PVT-MAP** Map Based Topography Information ( I-See Volvo Connect )
- **CRUIS-E** Extended Cruise Control
- **CRUIS-E5** Extended Cruise Control (I-Torque with Additional Fuel Saving Functions)
- **AMSO-AUT** Manual gear shift in automatic mode.
- **AVO-ENH** AMT Vocational option - enhanced
- **APF-ENH** Enhanced I-Shift PTO Functions
- **CS43B-O** Volvo 430mm single plate clutch
- **TC-MAOH2** High performance transmission cooler
- **2COM1100** Air Compressor - 1100 litres/minute
- **AIRIN-HI** High air intake, roofline position
- **AIRIN-LO** Low air intake, rear of cab position
- **ACL1ST-S** Air cleaner with two stage filter element
- **24A150BL** Alternator - 150 Amp

# MODEL RANGE

## FH13 6x4 Tractor Leaf Suspension FH 64T 3L

<input type="checkbox"/> <b>24A180BL</b>	Alternator - 180 Amp	<input checked="" type="checkbox"/> <b>BUPALARM</b>	Reverse alarm
<input checked="" type="checkbox"/> <b>PRIM-MAN</b>	Pump Prime - Manual	<input type="checkbox"/> <b>REMC-MF</b>	Multifunction Wireless Remote Control
<input type="checkbox"/> <b>AF-R</b>	Recirculation heated fuel filter	<input checked="" type="checkbox"/> <b>FIREX25A</b>	Fire Extinguisher - 2.5 kg
<input checked="" type="checkbox"/> <b>FUEFE2LW</b>	Dual fuel filter, engine mounted with water separator-large	<input checked="" type="checkbox"/> <b>WRITEPAD</b>	Writing pad
<input type="checkbox"/> <b>PTER-DIN</b>	Power Take Off / splined shaft groove (female) DIN5462.	<input checked="" type="checkbox"/> <b>DST-CF5</b>	Fully adjustable driver's comfort seat Air suspension, heated, integrated safety belt
<input type="checkbox"/> <b>PTER1400</b>	Rear engine mounted power-take-off with flange SAE 1410	<input type="checkbox"/> <b>SBD-RED</b>	Red safety belts, pass. & driver seats
<input type="checkbox"/> <b>HPE-F101</b>	F1-101 Hydraulic pump rear engine mounted	<input checked="" type="checkbox"/> <b>SBPRE-DS</b>	Drivers seat belt pretensioner
<input type="checkbox"/> <b>HPE-F41</b>	F1-41 Hydraulic pump rear engine mounted	<input checked="" type="checkbox"/> <b>PST-BAS1</b>	Basic passenger's seat
<input type="checkbox"/> <b>HPE-F51</b>	F1-51 Hydraulic pump rear engine mounted	<input type="checkbox"/> <b>PST-CF5</b>	Fully adjustable passenger comfort seat Air suspension, heated, safety belt
<input type="checkbox"/> <b>HPE-F61</b>	F1-61 Hydraulic pump rear engine mounted	<input type="checkbox"/> <b>SBPRE-PS</b>	Passenger Seatbelt Pretensioner
<input type="checkbox"/> <b>HPE-F81</b>	F1-81 Hydraulic pump rear engine mounted	<input type="checkbox"/> <b>ARMRE-BB</b>	Armrests both sides - driver's & passenger's seat
<input type="checkbox"/> <b>HPE-T53</b>	F2-53/53 twin flow hyd pump rear engine mounted	<input checked="" type="checkbox"/> <b>ARMRE-DB</b>	Armrests both sides - driver's seat
<input type="checkbox"/> <b>HPE-T70</b>	F2-70/53 twin flow hyd pump rear engine mounted	<input checked="" type="checkbox"/> <b>ARU-LEA</b>	Seat Armrest Upholstery - Leather
<input type="checkbox"/> <b>HPE-V45</b>	V1-45 variable pump rear engine mounted	<input checked="" type="checkbox"/> <b>GRABHI-B</b>	Instep Grab Handle - Standard
<input type="checkbox"/> <b>HPE-V75</b>	V1-75 variable pump rear engine mounted	<input type="checkbox"/> <b>GRABHI-L</b>	Instep Grab Handle - Leather Bound
<input type="checkbox"/> <b>PTR-D</b>	Low speed PTO with DIN connection	<input checked="" type="checkbox"/> <b>FMAT-RUB</b>	Floor Mats - Rubber
<input type="checkbox"/> <b>PTR-DH</b>	High speed PTO with DIN connection	<input checked="" type="checkbox"/> <b>LBK80F</b>	Lower Bunk 815mm Wide
<input type="checkbox"/> <b>PTR-DM</b>	Medium speed PTO with DIN connection	<input type="checkbox"/> <b>LBK80FRE</b>	Lower Bunk 815mm Wide - Electrically Reclinable
<input type="checkbox"/> <b>PTR-F</b>	PTO Flange Connection - Low Speed	<input type="checkbox"/> <b>LBK80FRM</b>	Lower Bunk 815mm Wide - Manually Reclinable
<input type="checkbox"/> <b>PTR-FH</b>	High speed PTO with flange connection	<input checked="" type="checkbox"/> <b>MATL-FI</b>	Spring Mattress Lower Bunk - Firm (100kg +)
<input type="checkbox"/> <b>PTR-FL</b>	Low speed PTO with flange connection	<input type="checkbox"/> <b>MATL-SF</b>	Mattress lower bunk - semi firm
<input type="checkbox"/> <b>PTRD-D</b>	PTO 2 DIN Connections - (Front & Rear)	<input type="checkbox"/> <b>OLMAT-BA</b>	Mattress overlay - basic
<input type="checkbox"/> <b>PTRD-D1</b>	PTO with 1 DIN + 1 flange connection rear + 1 DIN connection front	<input type="checkbox"/> <b>TBK70AD</b>	Top Bunk 700mm Wide - Foldable & Height Adjustable
<input type="checkbox"/> <b>PTRD-D2</b>	PTO with 2 flange connection rears + 1 DIN connection front	<input type="checkbox"/> <b>TBK70F</b>	Top Bunk 700mm Wide - Foldable
<input type="checkbox"/> <b>PTRD-F</b>	PTO with 1 flange connection	<input type="checkbox"/> <b>SLCP-BAS</b>	Sleeper Control Panel - Standard
<input type="checkbox"/> <b>HPG-F101</b>	F1-101 Hydraulic Pump	<input type="checkbox"/> <b>SAFE</b>	Safe box at bed-end
<input type="checkbox"/> <b>HPG-F41</b>	F1-41 Hydraulic Pump	<input type="checkbox"/> <b>RUS-BAS</b>	Rear Upper Cab Storage - 154 Litres for Sleeper/Globetrotter & 60 Litres for Day Cab
<input type="checkbox"/> <b>HPG-F61</b>	Parker F1-61 hydraulic pump (transmission mtd)	<input type="checkbox"/> <b>RUS-HIG</b>	Rear Upper Cab Storage - 245 Litres
<input type="checkbox"/> <b>HPG-F81</b>	F1-81 Hydraulic Pump	<input type="checkbox"/> <b>TABLE</b>	Table
<input type="checkbox"/> <b>STWM-LE</b>	Steering Wheel Material - Leather	<input type="checkbox"/> <b>REFR-RUS</b>	28 Litre Refrigerator in Upper Rear Storage
<input type="checkbox"/> <b>DRC-AMII</b>	DPF Regeneration- Auto Initialise/Manual on Demand/Manual Inhibit	<input type="checkbox"/> <b>REFRIG</b>	33 Litre Refrigerator Under Lower Bunk
<input type="checkbox"/> <b>DRC-AUTO</b>	DPF Regeneration- Fully Automatic (in motion)	<input type="checkbox"/> <b>MICRO-PK</b>	Preparation Kit for Microwave
<input checked="" type="checkbox"/> <b>ACCLF-D</b>	Acceleration Limiting Feature - Disabled	<input checked="" type="checkbox"/> <b>BOTH-D</b>	Bottle Holder in Driving Area
<input checked="" type="checkbox"/> <b>ESP-BAS1</b>	ESP Package (Tractor/Trailer Combinations with ABS/EBS Or Rigid with Standard COG)	<input type="checkbox"/> <b>BOTH-DL</b>	Bottle Holder in Driving & Resting Areas
<input type="checkbox"/> <b>ESP-BAS2</b>	ESP Package (Tractor/Trailer Combinations without ABS)	<input type="checkbox"/> <b>BOTH-L</b>	Bottle Holder in Resting Area
<input checked="" type="checkbox"/> <b>HWSS-ACB</b>	ACC & forward collision warning & emergency braking.	<input checked="" type="checkbox"/> <b>SOL12S</b>	12v Outlet in Sleeper Area
<input checked="" type="checkbox"/> <b>LSS-DW</b>	With lane departure system	<input checked="" type="checkbox"/> <b>INLI-BAS</b>	Interior night lights
<input type="checkbox"/> <b>LSS-DW3</b>	Pilot Assist - Active Continuous Lane Keeping	<input type="checkbox"/> <b>INLI-NL</b>	Interior White & Red (night) Light
<input checked="" type="checkbox"/> <b>LCS3</b>	LCS with Side Collision Avoidance Support (LHS) & Emergency Braking	<input type="checkbox"/> <b>INLI-NLD</b>	Interior light including night light and dimmer function
<input checked="" type="checkbox"/> <b>DAS-W</b>	Driver alert support warning	<input type="checkbox"/> <b>ARL-FLEX</b>	Flexible Reading Lamp (Snake Light)
<input type="checkbox"/> <b>DAS-W2</b>	Driver Alert Sensing System (monitoring of vehicle handling & driver attention)	<input checked="" type="checkbox"/> <b>RH-ER</b>	Roof Hatch - Electric (Metal Emergency Exit)
<input checked="" type="checkbox"/> <b>PB-AUT2</b>	Park Brake Applied Automatically When Driver Leaves Seat	<input type="checkbox"/> <b>RH-ETR</b>	Roof Hatch - Electric (Tinted Glass & Rear Opening)
<input type="checkbox"/> <b>RSSENS-W</b>	Rain Sensor to Activate Wipers	<input type="checkbox"/> <b>VANMIR</b>	Vanity Mirror
<input checked="" type="checkbox"/> <b>CU-ECC</b>	Climate controlled air conditioning	<input type="checkbox"/> <b>AS-FUS</b>	Auxiliary Shelf - Front Upper Storage
<input type="checkbox"/> <b>IGT-BUT</b>	Ignition Type - Push Button	<input type="checkbox"/> <b>INFOT-PK</b>	LCD screen mount - 6kgs max
<input type="checkbox"/> <b>IMMOBIL</b>	Engine Immobiliser		
<input type="checkbox"/> <b>ALARM-B</b>	Anti-theft alarm (cab)		
<input type="checkbox"/> <b>AUD-EXT</b>	Audio Extended		
<input type="checkbox"/> <b>BUPMON</b>	Back-Up Camera		
<input checked="" type="checkbox"/> <b>ISUNS-DS</b>	Interior Side Sunvisor - Driver's Door		
<input type="checkbox"/> <b>ISUNF-RE</b>	Windscreen Interior Sunvisor - Electric		
<input checked="" type="checkbox"/> <b>ISUNF-RM</b>	Windscreen Interior Sunvisor - Manual		
<input checked="" type="checkbox"/> <b>CSPL-BXD</b>	Centre section dash panel pull out drawer		
<input type="checkbox"/> <b>ADFS</b>	2 Din Slots in Front Shelf		

Standard Equipment       Optional Equipment

For more detailed information about cab and powertrain equipment, please refer to separate specification sheets.

For all possible options and combinations of options please consult your Volvo sales contact who can create a specification to match your requirements using the Volvo Sales Support system (VSS).

The factory reserves the right to modify design and change equipment without previous notification. The specification can vary from country to country.

# MODEL RANGE

## FH13 6x4 Tractor Leaf Suspension FH 64T 3L

- WILDBAR** Wildbar
- BUMP-SP** Bumper spoiler
- BUGNET** Insect Net in Front of Radiator
- CTILTP-E** Electrical Cab Tilt Pump
- FCABS-A** Front Cab Suspension - Air Bellows
- FCABS-M** Front Cab Suspension - Mechanical Spring
- RCABS-A** Rear Cab Suspension - Air Bellows
- RCABS-M** Rear Cab Suspension - Mechanical Spring
- HCC-INEX** Front hatch catch control-manual
- MIRCMCP** Camera Monitor System & Blind Spot Camera - Without Exterior Mirrors
- MIRCMS** Camera Monitor System - Without Exterior Mirrors
- MIRFLA3** Electrically operated flat mirrors  
Wide angle and close view mirror both sides
- MIRFLACP** Electrically Heated & Operated Flat Glass Mirrors with Front Monitoring Camera on Passenger Side
- AMIR-F20** Close view mirror
- SUNV-H** Exterior Sunvisor
- AD-ROOF** Aero-dynamic roof mounted deflector
- AD-SIDEL** Aero-dynamic cab side deflectors
- AD-SIDL2** Aerodynamic Cab Side Deflectors - Extensions
- GUARD-W** Windscreen Stoneguard
- HL-LED** LED Headlights
- HL-LED3** LED Headlights with Adaptive High Beam
- HL-CLEAN** Head lamp cleaning system
- DRL-LED** V-shaped LED Daytime Running Light
- DRIVL2** Integrated driving lamps
- UDRIVL** Without Integrated Driving Lights
- FOGL-WC** Integrated fog lamps
- CL-STAT** Corner light-static
- ASL-RF2** Spotlights Inside Globetrotter Sign Box
- IDLAMP-A** Identification Lamps - Amber
- BEACON-P** Beacon Light Wire Preparation
- CABPT-R2** 2 cab roof pass throughs, 1 on each side
- SPOTP-F** Aux spotlight preparation, 280W maximum
- ROS-ILP** Illuminated Cab Sign Prep Kit
- CSGN-GTR** Globetrotter Decal
- HORN-F1S** Single Electric Jericho Air Horn (Behind Grill)
- HORN-R2S** Chromed air horns, two roof mounted
- ANT-CBR** Antenna for CB Radio (Single Antenna)
- STUC-B** Storage Compartment Under Cab - Both Sides

### Superstructure

- 5WM-OBLP** 5th Wheel L-Profiles
- SRWL-PK** Wiring Prep for Chassis Mounted Working Lights - 3 Position Switch
- SWL-PK** Wiring Prep for Chassis Mounted Working Lights - 2 Position Switch
- WL-TA1W** Fifth wheel light
- WLC-H2W** 2 LED Work Lights - High Mounted
- WLC-PKH** Prep Kit for High Mounted Work Lights
- ECBB-HIG** Body Builder Module - Cab Module (14 High/4 Low)
- BBCHAS1** Body Builder Chassis Electrical Interface - 1 x 7 Pin Connector
- BBCHAS3** Body Builder Chassis Electrical Interface - 3 x 7 Pin Connectors

Standard Equipment

Optional Equipment

For more detailed information about cab and powertrain equipment, please refer to separate specification sheets.

For all possible options and combinations of options please consult your Volvo sales contact who can create a specification to match your requirements using the Volvo Sales Support system (VSS).

The factory reserves the right to modify design and change equipment without previous notification. The specification can vary from country to country.

- EXSTER** External Steering via Body Builder's Module
- TD-LED** LED trailer detection sensor
- AESW2PK** 2 Flexible Switches (AUX1 & AUX2) + Additional 4 Flexible Switches
- AUXSW-4** Wiring Prep. for 4 Extra Bodybuilder Switches (switches not included)

### Delivery services

- TGW-4GWL** Telematics Gateway with 4G/LTE & WLAN
- FMS-PK** Fleet Management System Gateway
- DRUT1** "My Truck" Smartphone App. 1 Year Prepaid
- DRUT2** "My Truck" Smartphone App. 2 Year Prepaid
- DRUT3** "My Truck" Smartphone App. 3 Year Prepaid
- DRUT4** "My Truck" Smartphone App. 4 Year Prepaid
- DRUT5** "My Truck" Smartphone App. 5 Year Prepaid
- TSRS2** Traffic Sign Recognition System

# MODEL RANGE

FH13 6x4 Tractor Leaf Suspension FH 64T 3L

---

Volvo Trucks. Driving Progress