

---

## Operating manual (Translation of the original version)

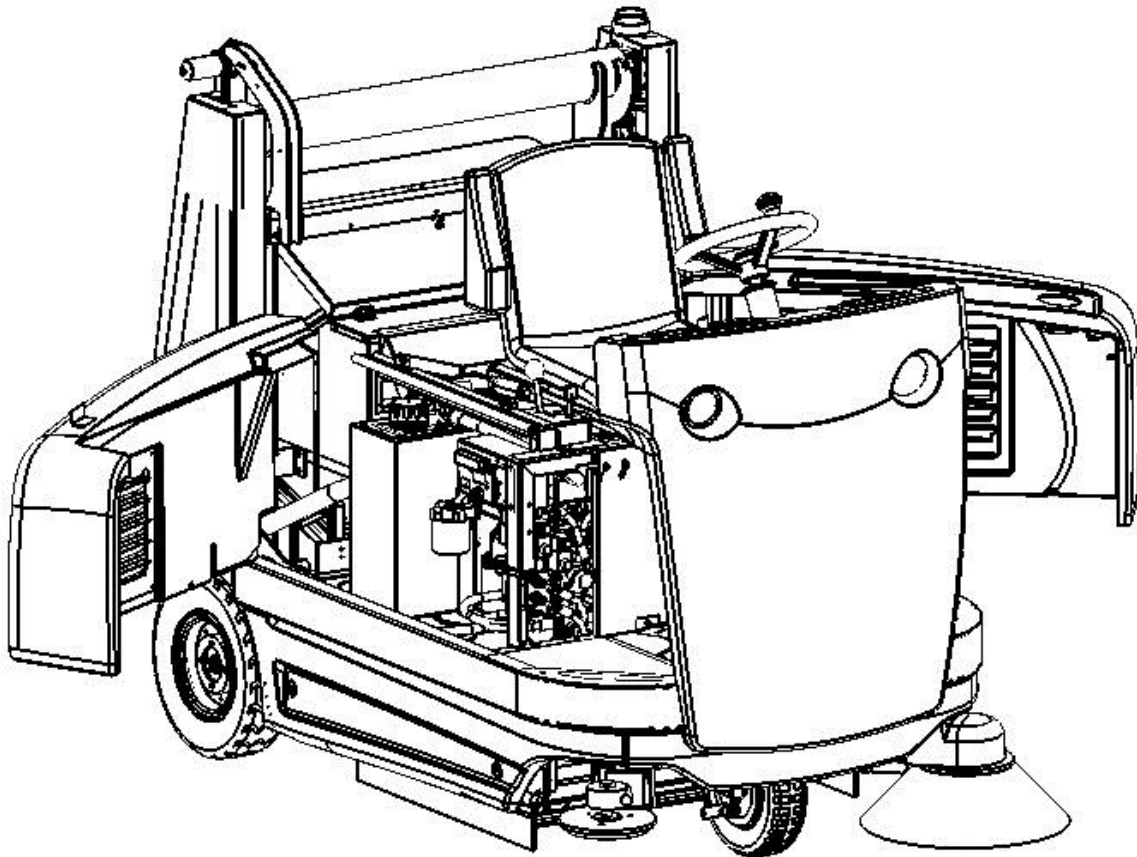

---

**ABCO PRODUCTS PTY LTD**

44 John Street  
Bentley WA 6102  
Australia

Phone: 1800 177 399  
[www.abcopro.com.au](http://www.abcopro.com.au)

---

## Table of Content

<b>1</b>	<b>Introduction.....</b>	<b>4</b>
1.1	Usage conformant with intended purpose .....	4
<b>2</b>	<b>Safety information .....</b>	<b>5</b>
2.1	Safety Devices .....	7
<b>3</b>	<b>Description of the unit .....</b>	<b>8</b>
3.1	Control elements.....	9
3.2	The Operator Panel .....	9
3.3	Charging status indication.....	10
3.4	Commissioning .....	10
<b>4</b>	<b>Operation.....</b>	<b>11</b>
4.1	Drive operation.....	11
4.2	Sweeping Operation .....	12
4.2.1	Sweeping wet trash .....	12
4.3	Shutting Down the Vacuum Sweeper .....	12
4.4	Filter cleaning.....	13
4.5	Emptying the dust box .....	13
<b>5</b>	<b>Maintenance.....</b>	<b>14</b>
5.1	Safety Information.....	14
5.2	Reinigung.....	14
5.3	Charging the batteries.....	15
5.4	Changing the filter.....	15
5.4.1	Removing the filter.....	15
5.4.2	Attaching the filter .....	16
5.5	Changing the sweeping rollers .....	16
5.5.1	Removing the sweeping rollers .....	16
5.5.2	Assembly of the sweeping rollers.....	17
5.6	Side broom.....	17
5.6.1	Attaching the side broom.....	17
5.6.2	Detaching the side brooms.....	18
5.7	Tipper mechanism .....	18
5.8	Maintenance Table .....	19
5.8.1	Maintenance daily.....	19

## Table of Content

---

5.8.2	in addition, every 50 operating hours .....	19
5.8.3	in addition, every 100 operating hours .....	19
5.9	Faults, fault indications and remedies .....	20
5.10	Technical data.....	21
5.11	Product designation .....	21
5.12	Disposal .....	21
5.13	Accessories and spare parts .....	22
5.14	Service .....	22
5.15	Transport.....	22
<b>6</b>	<b>EC Declaration of conformity (Translation of the original version) .....</b>	<b>23</b>

# 1 Introduction

This operating manual contains instructions for using the hand-operated sweeper.

Our products are subject to continuous improvement. Therefore, design changes that were made after this manual went to print could not be incorporated. If you have any questions, please contact our Service department.

The operating manual must be read and applied by all persons who operate the sweeper.

Apart from the operating manual and the regulations for accident prevention applicable in the country of use and the location of use, the common, recognised rules for safe and technically correct working must also be followed.

## 1.1 Usage conformant with intended purpose

The appliance is intended exclusively for sweeping on solid surfaces (for example.: parking areas, walkways, shop floors). The area to be swept should not be wet.

The sweeper may only be used by reliable and instructed personnel. revent children, juveniles and other unauthorised persons from using the machine (e.g. by pulling out the key after use).

Any other use, or any use over and above that, will be considered to be non-conformant with intended purpose. The manufacturer rejects any and all liability for damage resulting from such use. The risk is that of the user alone.

Usage conformant with intended purpose also includes compliance with the operating manual and the inspection and maintenance specifications. Drive the sweeper only along expressly marked routes and spaces.

## 2 Safety information

---

1. The machine should only be used in a flawless state, as well as in keeping with its intended purpose, in a safety-conscious and risk-conscious manner and in compliance with these operating instructions.
2. In addition to the operating manual, please heed general legal and other binding regulations for accident prevention and environmental protection.
3. Sweeping and picking up of flammable, toxic or explosive substances, along with flammable gases or diluted acids and solvents, burning or smouldering objects is prohibited!
4. The appliance is not suitable for picking up fluids, cables, cords, wires or the like.
5. The machine should only be used with the dust box fitted to prevent injuries caused by parts being slung out.
6. Transporting loads with the sweeper is not allowed.
7. Faults should be eliminated immediately, particularly those that could impair safety.
8. Do not make any changes, modifications or additions to the sweeper without the approval of the manufacturer.
9. Replacement parts must meet manufacturer specifications. This is always ensured by using original replacement parts.
10. Ensure that operating media, auxiliary media and replacement parts are disposed of in a safe and environmentally-friendly manner, particularly batteries!
11. Suitable non-slip footwear should be worn to avoid accidents.
12. If you have any questions, please contact our Service department.
13. Persons (including children) who are not able to use this machine safely due to their physical, sensory or mental capabilities or their inexperience or lack of knowledge may not use this machine without the supervision or instruction by a responsible person! Children should be supervised to ensure that they do not play with the appliance.
14. Caution: loose clothing can be caught and drawn in on rotating parts.
15. The operating instructions provided by the battery manufacturer relating to his product and legal specifications for the handling of accumulator batteries should be heeded!

16. Charge flat batteries directly after use and only in well-ventilated rooms.
17. Keep naked flames and electrical sparks away from the charging area, since a highly-explosive electrolytic gas mixture is generated when batteries are being charged.
18. Note that the accumulator batteries are filled with battery acid.
19. Batteries should always be kept clean and dry to avoid leakage currents! Never short-circuit battery poles!
20. Smoking, eating and drinking should be avoided in the vicinity of the battery charging station to avoid risks to health.
21. Batteries should only be charged with the hood opened and secured with the holder.
22. Warning: risk of crushing. Maintain a safety clearance of 2 metres to other people during emptying through high dumping.
23. Maintenance and repair work on the hydraulics and high dumping mechanism should only be entrusted to a specialist firm.
24. Observe the maximum climbing capability and maximum permissible slant specified in the technical data when driving transversely to an incline. The unit can topple over if the steering is turned too sharply, particularly on inclines. Adjust your driving style and speed to suit conditions.
25. The machine is not approved for use on roads or streets.

### 2.1 Safety Devices

The vacuum sweeper only starts if:

- the starting key is in the ON position (1)
- the driver's seat is in a horizontal position
- the side lining is correctly closed.

The vacuum sweeper only starts if:

- the starting key is in the ON position (1)
- the driver's seat is in a horizontal position
- the side lining is correctly closed
- the EMERGENCY STOP button has not been pressed
- all the loads are switched off
- the direction of movement switch is at Neutral.

The power supply to the engine is interrupted when:

- the driver's seat is unfolded to an upright position
  - the side lining is opened
  - the key switch is turned to OFF (0)
  - the EMERGENCY STOP button is pressed.
- 
- Yellow rotating warning beacon on the highest point of the machine.
  - If the direction of movement is set to reverse movement, an acoustic signal is sounded.
  - If the gas pedal is pressed during the starting process, the electrical supply to the drive engine is interrupted.

### 3 Description of the unit

The vacuum sweeper is driven by an electric engine.

The sweeping process is carried out by two side brooms, which move the sweepings to the two sweeping rollers that are mounted at a 90-degree angle to the direction of movement.

These sweeping rollers throw the sweepings into the rear dust box.

The dust that is collected by the sweeping rollers is held by the dust suction system in a lamellar filter.

The lamellar filter can be cleaned by means of a jolting mechanism.

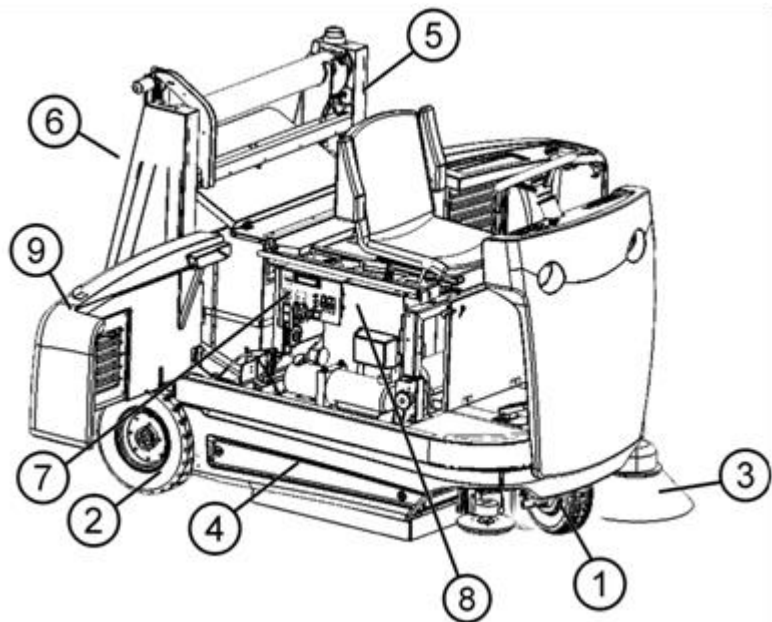

- |   |                                |   |                                |
|---|--------------------------------|---|--------------------------------|
| 1 | Front wheel                    | 6 | Dust box                       |
| 2 | Rear wheel                     | 7 | Fuse box                       |
| 3 | Side broom                     | 8 | Battery box with charging plug |
| 4 | Cover for the sweeping rollers | 9 | opened side lining             |
| 5 | Tipper mechanism               |   |                                |



### 3.1 Control elements

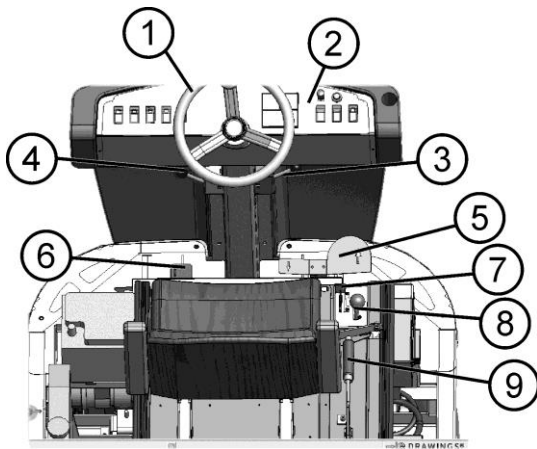

- |                                    |                                   |
|------------------------------------|-----------------------------------|
| 1 Steering wheel                   | 6 Brake pedal                     |
| 2 Operator panel                   | 7 Lowering lever, sweeping roller |
| 3 Lowering lever, right side broom | 8 EMERGENCY STOP                  |
| 4 Lowering lever, left side broom  | 9 Parking brake                   |
| 5 Accelerator pedal                |                                   |



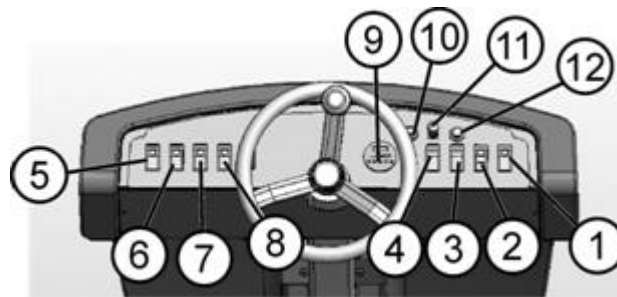

### 3.2 The Operator Panel



- |  |   |
|--|---|
| 1 Switch, right side broom                           | 7 Switch, suction and filter cleaning                     |
| 2 Rocker for forward/reverse movement                | 8 Switch for the headlamps (optional)                     |
| 3 Switch for swivelling the dust container           | 9 Charging status indication with operating hours counter |
| 4 Switch for lowering and raising the dust container | 10 Key switch   |
| 5 Switch, left side broom                            | 11 Speed control, side broom (optional)                   |
| 6 Switch, sweeping rollers                           | 12 Horn   |

### 3.3 Charging status indication

Meaning of the indications:

lit LED	charging condition of battery
Red Yellow Green Green Green	
	condition fully charged
	operating/charging condition uncritical
	operating/only for a short time longer
	operating/soon critical
	operating/critical

### 3.4 Commissioning

- Ensure that the machine was supplied complete and free of faults.



**If that is not the case, please contact the concerned dealer or our service department.**

- Open the transportation packing and move the machine carefully off the pallet. Please use suitable aids.
- Unfold the seat laterally and fix it.
- Open the side lining.
- Fix the side broom arms in the highest position and then fix the side brooms. (also see: Fixing the side brooms)
- Connect the plus pole of the battery.
- Close the side lining.
- Fold the seat back into the original position.

The vacuum sweeper machine is ready for use.

## 4 Operation

### 4.1 Drive operation

**To start the engine:**

- Set all loads to OFF.
- Operate the brake pedal or put on the parking brake.
- Insert the key in the key switch and turn it clockwise till the engine starts.

**Do not step on the accelerator while doing so.**



The forward or reverse movement of the machine is pre-selected with a switch on the operator panel.

- Set the switch to the required direction of travel.
- Release the brake.
- Use the accelerator pedal to start movement.

The machine moves in the selected direction of travel.

**Caution!**



If you wish to change the direction of travel, you must first press the brake pedal or set the parking brake to prevent the machine from moving.

Operate the switch for direction of movement only when the machine is at standstill.

**To stop the engine:**

- Rotate the key anti-clockwise till the engine goes off.
- Operate the parking brake.
- Pull out the key.

---

## 4.2 Sweeping Operation

- Start the movement.

The sweeping rollers and the individual side brooms can be switched ON and OFF individually.

You can start operation of the side brooms and rollers by actuating the corresponding switch.

### Height adjustment

- The height of the side brooms is adjusted by means of levers on the steering column. Each of the side brooms can be made operational separately.
- The height of the sweeping rollers is adjusted by means of a lever on the right next to the operator seat. To lower the sweeping rollers, the lever must be disengaged.

### 4.2.1 Sweeping wet trash

Caution!



When sweeping wet trash, it is recommended that the fan should not be switched on, to avoid damage and blocking of the filter.

The fan can be put on or turned off by using a switch.

## 4.3 Shutting Down the Vacuum Sweeper

- Drive the machine to an area provided for (assigned to) it.
- Turn the key anti-clockwise to switch off the engine and pull out the key.
- Pull the hand brake.
- Set the side brooms and the sweeping rollers in the top position.

Caution!



If the sweeping brushes are not put in the top position, the bristles are constantly under load at the state of rest and therefore get worn prematurely during use.

- Thoroughly empty the dust box upon completion of the sweeping.

### 4.4 Filter cleaning

- Switch off the fan and let it come to a stop.
- Ensure that the dust filter has been attached.
- Press the button for cleaning the filter for a couple of seconds

After the filter cleaning, you should wait for a couple of seconds for the fine dust to settle.

### 4.5 Emptying the dust box

In order not to reduce the sweeping capacity, the dust box must be emptied at regular intervals.

- Switch off the side broom and sweeping rollers.
- Set the side brooms and the sweeping rollers in the top position.
- Ensure that the dust box is not swung.
- Move back to a suitable container or unloading station.
- By pressing the switch for raising/lowering, move the dust container upwards till it has reached the required height for emptying (limit switch).
- Operate the switch for swinging the dust box for emptying. Swinging is only possible from a minimum height of 1 m.
- Swing back the dust box by pressing the corresponding switch on the operator panel.
- Operate the switch for lowering the dust box to move the dust box back into the machine. Lowering is only possible with the dust box swung back into the starting position.

#### **Danger**



When emptying the dust box, pay attention to keeping a sufficient safe distance to other persons.

When operating the lifting hydraulics and during emptying of the dust box, all persons must keep a distance of approx. 2 m from the machine.

## 5 Maintenance

### 5.1 Safety Information

Only complete the type of maintenance work described in the following chapter. All other maintenance and upkeep work may only be carried out by the manufacturer or by companies and persons authorised by the manufacturer, who are familiar with the relevant safety specifications, because portable devices in industrial use are subject to the safety test according to VDE 0701.

Closely follow the steps listed in the maintenance instructions. The improper completion of maintenance tasks may result in malfunctions when using the sweeper and may possibly render the warranty granted null and void.

When working on the electrical system, the battery should be disconnected.

Maintenance work/ troubleshooting at the electric motor must not be done while the electric motor is running.

Use only flawless and appropriate tools to complete maintenance work.

Note the requirements for spare parts.

If covers and/or safety devices were removed during maintenance work/repairs, they will have to be reattached prior to starting the sweeper.

For carrying out any work on the sweeper, it must be switched off and secured from rolling away by accident.

### 5.2 Reinigung

Die Kehrsaugmaschine darf nur im ausgeschalteten Zustand und trocken gereinigt werden (z.B.: Abfegen).

Die Kehrsaugmaschine ist eine Maschine mit elektrischen Bauteilen.

**VORSICHT**

---

**Feuchtigkeit schädigt die Elektronik des Gerätes!**

Feuchtigkeit kann zu Kriechströmen und Kurzschlüssen führen.

---

Verwenden Sie keinen Hochdruckreiniger.

## 5.3 Charging the batteries

- Switch off the vacuum sweeper.
- To do so, unfold the driver's seat laterally and fix it.
- Connect the charger to the charging socket 1 of the vacuum sweeper.
- Connect the mains plug of the charger to the mains supply.

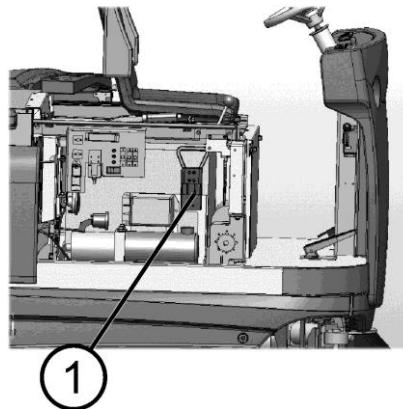

Note

If the battery is fully discharged, the charging process takes about 10 hours (with the original charger accessory from the manufacturer).

Operate the vacuum sweeper only if there is sufficient voltage at the batteries. The machine switches off automatically when the batteries are discharged to such an extent that they could get damaged.

In such a case, switch off all loads for about 2 minutes.

Next, drive to the charging station only in driving mode and immediately charge the batteries.

## 5.4 Changing the filter

### 5.4.1 Removing the filter

- Open the caps 1 and lift the filter cover 2.
- Thread the hook through the eyelet 3.
- Lift the jolting mechanism 4.
- Remove the old filter 5.

### 5.4.2 Attaching the filter

- Place the filter **5** in the frame.
- Lower the jolting mechanism **4**.
- Loosen the hook from the eyelet **3**.
- Close the filter cover **2**.
- Close the caps **1**.

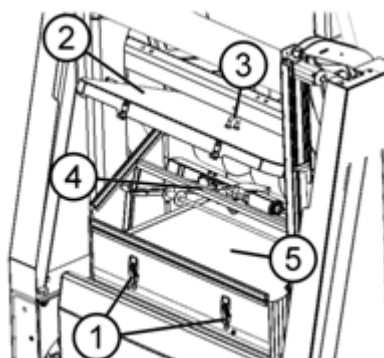

## 5.5 Changing the sweeping rollers

- Switch off the machine and pull out the ignition key.
- Apply the hand brake

### 5.5.1 Removing the sweeping rollers

To take off the sweeping rollers, follow the instructions below:

- Open the lower left side panelling as viewed in the direction of travel.
- Loosen the three star knobs **1**.
- Lower the sweeping rollers.
- Open the swinging plate **2** and remove the cover plate **3**.
- Loosen the roller height adjusting device.
- The rollers can be pulled out to the side.
- Remove any sweepings present in the roller box.

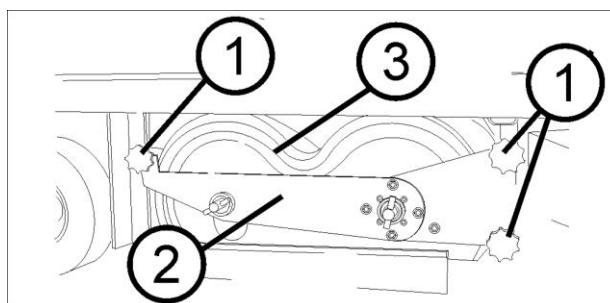



### 5.5.2 Assembly of the sweeping rollers

To assemble the sweeping rollers, follow the instructions below:

- Push the new roller from the side into the roller box.



#### Attention!

Pay attention to the direction of rotation **4** of the sweeping rollers.

Ensure that the roller fits correctly on the roller carrier.

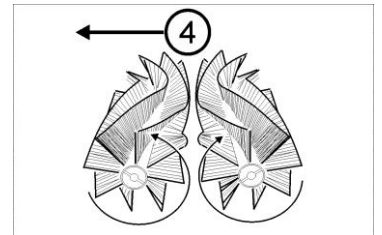

- Put on the cover plate again and close the swinging plate.
- Join the swinging plate with the roller height adjusting device.
- Fix the swinging plate and cover plate with the 3 star knobs.
- Close and lock the side panelling.
- Correct the roller height

### 5.6 Side broom

- Switch off the machine and pull out the ignition key.
- Apply the hand brake.

#### 5.6.1 Attaching the side broom

- Push the sleeve **1** onto the engine axis **2**.
- Hold the side broom **3** below the side broom arm and rotate the side broom in such a way that the groove and the key are in alignment
- Press the side broom upwards and fix it with the washer and the screw **4**.

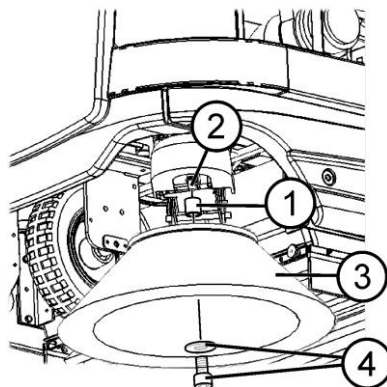

### 5.6.2 Detaching the side brooms

- Loosen screw 4 below the side broom and remove the broom from its mounting.

## 5.7 Tipper mechanism



### **Danger**

When working with the tipper, the dust box with the tipping arms must be secured against sudden loss of pressure in the hydraulic system (e.g. cracking of a pipe).

Therefore, do the following:

- Move the tipper completely to the top.
- Pull the spring pin at the assembly securing angle.
- Remove the bolts between the assembly securing angle and the lifting arm.
- Move the assembly securing arm downwards till it is parallel to the cylinder.
- Secure the assembly securing angle again with the bolts and spring pin.



### **Attention!**

The tipper system may not be moved in this state.

### **5.8 Maintenance Table**

#### **5.8.1 Maintenance daily**

Check the battery acid level and if required, replenish distilled water.

Charge the battery.

Check the machine for visible damage and malfunctions.

Empty the dust container.

Check the broom tunnel and roller tunnel for adhered parts, or dirt particles that have got stuck, which would narrow the broom tunnel and constrict the free movement of the roller brushes.

Check the state of the dust filter, clean if required.

#### **5.8.2 in addition, every 50 operating hours**

clean the battery poles and grease them.

Check the sweeping rollers for wear and foreign bodies, replace them if required

Check the sweeping mirror and adjust it if required

Check the side broom setting for wear, if required, set it or replace it.

#### **5.8.3 in addition, every 100 operating hours**

Check the cable connections for firmness

Check the cable insulation, replace cables if required.

Check all the chains for wear or impermissible tension, replace if required.

Check all the bearings for wear.

Check all the seals for damage or correct seating.

Check the cable connections for firmness, replace faulty cables

Check the dust filter, replace if required.

Check the collected dust for foreign bodies and clean it.

#### **In addition**

Check the brake pads of the drum brake

## 5.9 Faults, fault indications and remedies

Fault	Possible cause	Remedy
Engine does not work	key switch was not activated	Turn the key
	EMERGENCY STOP switch activated	Release the EMERGENCY STOP
	Battery fully discharged	Charge the battery
	Fault in electrical connection	Check the plug-and-socket connections
	The side lining is still open	Close the side lining
Drive does not work despite indication on control instrument	When switching on, the switch for direction of movement was set to Forward or Reverse	Set the switch to Neutral
	Accelerator was pressed while switching on	Release the accelerator
	Defective fuse	Replace the fuse
	Problem with the control electronics	Call the Service department
Electrical loads are not working	Defective fuse	Replace the fuse
	Fault in electrical connection	Check the plug-and-socket connections
	Fuses are constantly defective	Check the respective load. Especially check the sweeping rollers to see if there are tapes, cables, ropes etc. wound around them.
Results of sweeping unsatisfactory	Side broom or brush roller not lowered	Lower them
	Side broom or brush roller worn	Re-adjust and if required, replace the brushes
	Trajectory blocked by refuse	Check and clean the roller space
	Brush rollers are blocked because of refuse (ropes, string or the like)	Clean the brush rollers and roller bearings, check the bearings for damage
	Brush rollers are blocked because of refuse (ropes, string or the like)	Check the side brooms and remove hindering objects
	Side brooms and/or roller belts worn	Check and replace the belts
Fault in the drive	Drive not set correctly	Set the drive
	Blocking of the steering roller or the impellers by refuse	Remove the blockage
Severe dust formation during sweeping	Filter severely fouled	Clean the filter
	Filter used up / filter material worn	Check and replace the filter
	Filter not in correct position	Correct the filter position
	Leaks and as a result, suction of the wrong air in the area of the filter chamber	check for the suction of wrong air
	Filter box not inserted correctly	Check whether filter box placed correctly

## 5.10 Technical data

Dimensions and weight	
Length	1850 mm
Width	1132 mm
Height	1540 mm
Weight (empty)	630 kg
Sweeping width:	
- without side brooms	800 mm
- With 1 side broom	1100 mm
- With 2 side brooms	1300 mm
Dust container volume	150 ltr
Climbing power	20 %

Speed	
max	8 km/h
Net power output of drive	1.5 kW
Engine	Geared motor 24V
Engine type	Nose wheel engine

## 5.11 Product designation

Type plate

The type plate is located, viewed in the direction of movement, on the right on the rear frame crossbeam.



## 5.12 Disposal

Dispose of faulty parts, especially electrical components, batteries and plastic parts according to the locally applicable waste disposal specifications.

Used batteries must be disposed of according to Directive 2006/66/EC.

### **5.13 Accessories and spare parts**

Accessories and spare parts must conform to the requirements of the manufacturer. This is ensured by using genuine replacement parts.

### **5.14 Service**

ABCO PRODUCTS PTY LTD

44 John Street

Bentley WA 6102

Australia

Telefon: 1800 177 399

[www.abcopro.com.au](http://www.abcopro.com.au)

### **5.15 Transport**

Transport the machine only in the switched-off condition, sufficiently well fastened.

## 6 EC Declaration of conformity (Translation of the original version)

**according to the EC Machine Directive 2006/42/EC, Appendix II, No. 1A**

Mr. Kai Stolzenberg – Management of the Stolzenberg GmbH & Co. KG, Hamburger Straße 15-17, D-49124 Georgsmarienhütte - is authorized to arrange technical information.

**We hereby declare that the machine described below corresponds, in its conception and construction, as well as the model brought into use by us, to the basic safety and health requirements of the EC Machine Directive 2006/42/EC. In case of a change being made that has not previously been agreed with us, this declaration will lose its validity.**

Manufacturer:	Abco, 44 John Street, Bentley WA 6102, Australia
Designation of the machine:	STR1300
Machine type:	Suction sweeper with tandem-roller-system
relevant EC Directives:	Directive 2006/42/EC Directive 2000/14/EC Directive 2004/108/EC

**The following standards, in particular, were applied:**

EN 292  
EN 294

DIN EN 61000-6-2  
DIN EN 60335-1  
DIN EN 60335-2-69  
DIN EN 60335-2-72

Bentley, 25.11.14

.....  
(General Manager)