

Cobra®

400mm Gas Fryer

Model CF2



INSTALLATION AND OPERATION MANUAL

MANUFACTURED BY

Moffat Limited

Rolleston 7675
New Zealand

INTERNATIONAL CONTACTS

AUSTRALIA

Moffat Pty Limited

E.Mail: vsales@moffat.com.au
Main Office: (tel): +61 (03) 9518 3888
(fax): +61 (03) 9518 3833
Service: (tel): 1800 622 216
Spares: (tel): 1800 337 963
Customer Service: (tel): 1800 335 315
(fax): 1800 350 281

NEW ZEALAND

Moffat Limited

Web: www.moffat.co.nz
E.Mail: sales@moffat.co.nz
Main Office: (tel): 0800 663328

UNITED KINGDOM

Blue Seal

Web: www.blue-seal.co.uk
E.Mail: sales@blue-seal.co.uk
Sales: (tel): +44 121 327 5575
(fax): +44 121 327 9711
Spares: (tel): +44 121 322 6640
(fax): +44 121 327 9201
Service: (tel): +44 121 322 6644
(fax): +44 121 327 6257

REST OF WORLD

Moffat Limited

Web: www.moffat.co.nz
E.Mail: export@moffat.co.nz

The reproduction or copying of any part of this manual by any means whatsoever is strictly forbidden unless authorized previously in writing by the manufacturer.

In line with policy to continually develop and improve its products, Moffat Ltd. reserves the right to change the specifications and design without prior notice.

© Copyright Moffat Ltd. March 2015.

COBRA CF2 - 400mm GAS FRYER (Single Tank - 18 Ltr)

Part 1	Introduction.....	2
Part 2	Specifications	3
	General	3
	Gas Connection.....	3
	Gas Supply Requirements.....	4
Part 3	Installation.....	4
	Installation Requirements.....	5
	Unpacking	5
	Location.....	5
	Clearances.....	5
	Assembly.....	6
	Gas Connection.....	6
	Commissioning.....	7
Part 4	Operation.....	8
	Operation Guide.....	8
	Description of Controls	8
	Before Use.....	9
	Filling the Tank.....	9
	Lighting the Pilot Burner.....	9
	Lighting the Main Burner	10
	Set the Operating Temperature	10
	Turning Fryer to 'Pilot' or 'Off' Positions	10
	Guide and Care of Frying Oils and Fats.....	10
Part 5	Cleaning and Maintenance.....	11
	General	11
	Draining and Cleaning.....	11
	Daily Cleaning	11
	Weekly Cleaning	12
	Periodic Maintenance	12
Part 6	Gas Conversion.....	13
	Gas Conversion Procedure	13
	Gas Specifications	15
Part 7	Replacement Parts List.....	16

Part 1 Introduction

We are confident that you will be delighted with your Cobra 400mm Gas Fryer, and it will become a most valued appliance in your commercial kitchen.

To ensure you receive the utmost benefit from your new Cobra Appliance, there are two important things you can do.

Firstly:

Please read this instruction book carefully and follow the directions given. The time taken will be well spent.

Secondly:

If you are unsure of any aspect of the installation, instructions or performance of your appliance, contact your Cobra Fryer dealer promptly. In many cases a phone call could answer your question.

WARNING:

IMPROPER INSTALLATION, ADJUSTMENT, ALTERATION, SERVICE OR MAINTENANCE CAN CAUSE PROPERTY DAMAGE, INJURY OR DEATH. READ THE INSTALLATION, OPERATING AND MAINTENANCE INSTRUCTIONS THOROUGHLY BEFORE INSTALLING OR SERVICING THIS APPLIANCE.

WARNING:

INSTRUCTIONS TO BE FOLLOWED IN THE EVENT THE USER SMELLS GAS ARE TO BE POSTED IN A PROMINENT LOCATION. THIS INFORMATION SHALL BE OBTAINED BY CONSULTING THE LOCAL GAS SUPPLIER.

WARNING:

GREAT CARE MUST BE TAKEN BY THE OPERATOR TO USE THE EQUIPMENT SAFELY TO GUARD IT AGAINST RISK OF FIRE.

- THE APPLIANCE MUST **NOT** BE LEFT 'ON', UNATTENDED.
- IT IS RECOMMENDED THAT A REGULAR INSPECTION IS MADE BY A COMPETENT SERVICEMAN TO ENSURE CORRECT AND SAFE OPERATION OF YOUR APPLIANCE IS MAINTAINED.
- **DO NOT** STORE OR USE GASOLINE OR OTHER FLAMMABLE VAPOURS OR LIQUIDS IN THE VICINITY OF THIS OR ANY OTHER APPLIANCE.
- **DO NOT** SPRAY AEROSOLS IN THE VICINITY OF THIS APPLIANCE WHILE IT IS IN OPERATION.

CAUTION:

This appliance is;

- For professional use and is to be used by qualified persons only.
- Only qualified service persons are to carry out installation, servicing and gas conversion operations.
- Components having adjustments protected (e.g. paint sealed) by the manufacturer should not be adjusted by the user / operator.
- **DO NOT** operate the appliance without the legs supplied fitted.

Part 2 Specifications

Model Covered in this Specification -

CF2 400mm GAS FRYER (Single Tank - 18 Ltr).

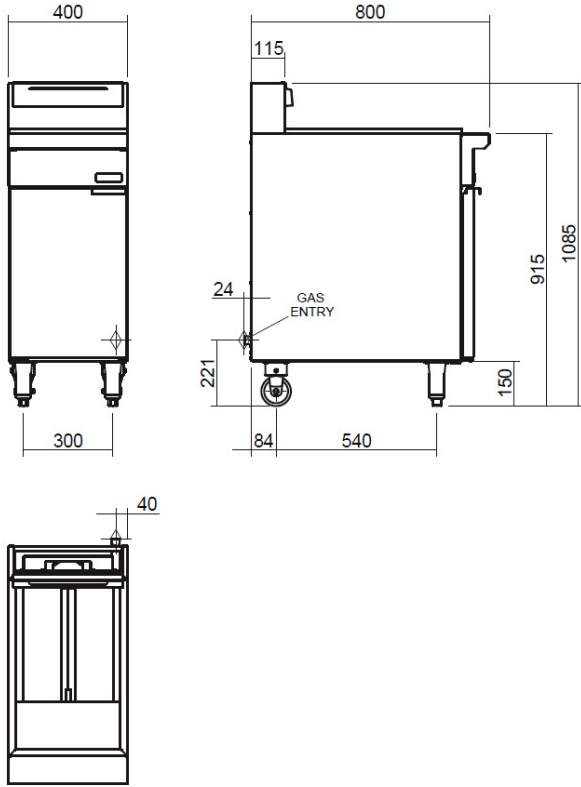

Gas Connection

Gas supply connection point is located 40mm from the right hand side, 24mm from the rear and 221mm from the floor.

- Flexible Hose Connection

If a Gas Hose assembly is used to connect this appliance, the hose and all fittings must have a minimum $\frac{3}{4}$ " (Natural Gas) or $\frac{1}{2}$ " (LPG) inside bore diameter to ensure gas flow rate capacity required by this appliance is achieved.

This must be verified by the operating pressure testing at the maximum gas supply demand condition.

The Gas Hose assembly should also be classified for use in the commercial kitchen conditions, the appliance will be used in.

Recommended Gas Hose Assembly Specification:
- AS/NZS 1869 Class B or D compliant or equivalent, that meets the following requirements:-

Class	Max Working Pressure at $23 \pm 2^\circ\text{C}$	Working Temperature Range	Resistance to Oil
B	7.0 kPa	- 20°C to + 125°C	Oil resistant lining and cover.
D	2.6 MPa		

General

A commercial gas fired fryer fitted with a 90MJ/hr, Multi Jet Target 'U' Burner and pilot burner, controlled by a single gas controller which controls both pilot and main burner. It is available in single model type only.

This Fryer is fitted with an Over Temperature Safety Cut Out system with Full Flame Failure Safety Controls.

An open tank design to make cleaning a simple and easy task.

Gas Supply Requirements

- Non UK Models:

	Gas Natural	LP Gas / Butane	Town Gas (**)
Input Rating (N.H.G.C.)	90 MJ/hr (85,300 Btu/hr)	90 MJ/hr (85,300 Btu/hr)	90 MJ/hr (85,300 Btu/hr)
Supply Pressure	1.13 - 2.0 kPa (4.5" - 8.0" w.c.)	2.75 - 3.0 kPa (11" - 12" w.c.)	0.75 - 1.5 kPa (3" - 6" w.c.)
Burner Operating Pressure	0.90 kPa (*)	2.5 kPa (*)	0.39 kPa (*)
	(3.6" w.c.)	(10.0" w.c.)	(1.6" w.c.)
Gas Connection	¾" BSP Male		

- UK Models:

Appliance Classification:

Category: II_{2H3P} (20, 37). Flue Type: A₁.

	Natural Gas (G20)	Propane (G31)
Heat Input (nett)	22.5 kW	22.5 kW
Gas Rate	2.26 m ³ /hr	1.75 kg/hr
Supply Pressure	20 mbar	37 mbar
Burner Operating Pressure	9.0 mbar (*)	25 mbar (*)
Gas Connection	¾" BSP Male	

NOTE:

- (*) Measure the Burner Operating Pressure at the Operating Pressure Test Point (Lower - Out) on the Gas Control Valve, with Main Burner operating.
- (**) TOWN GAS Only - Gas Control Valve - Operating Pressure Adjusting Screw should be replaced with the Knock Out Plug supplied in Town Gas Kit and the operating pressure adjusted at the External Gas Pressure Regulator. Both the Knock Out Plug and External Regulator are supplied in the Town Gas Conversion Kit.
- Refer to the 'Gas Conversion and Specifications' section of this manual for further details.

Installation Requirements

NOTE:

It is most important that this appliance is installed correctly and that operation is correct before use. Installation shall comply with local, gas, health and safety requirements.

This appliance shall be installed with sufficient ventilation to prevent the occurrence of unacceptable concentrations of health harmful substances in the room, the appliance is installed in.

Cobra gas fryers are designed to provide years of satisfactory service and correct installation is essential to achieve the best performance, efficiency and trouble-free operation.

This appliance must be installed in accordance with National installation codes and in addition, in accordance with relevant National / Local codes covering gas and fire safety.

Australia/New Zealand:

AS/NZS 5601- Gas Installations.

United Kingdom: Gas Safety (Installation and Use) Regulations 1998.

Ireland: IS 820 - Non Domestic Gas Installations.

Installations must be carried out by qualified service persons only. Failure to install equipment to the relevant codes and manufacturer's specifications shown in this section will void the warranty.

Components having adjustments protected (e.g. paint sealed) by manufacturer, are only to be adjusted by a qualified service agent. They are not to be adjusted by the installation person.

Unpacking

- Remove all packaging and transit protection from the appliance including all protective plastic coating from the door outer panel and exterior stainless steel panels.
- Check equipment and parts for damage. Report any damage immediately to the carrier and distributor.
- Report any deficiencies to the distributor who supplied the appliance.
- Check that the available gas supply is correct to that shown on the rating plate located on the inside of the access door.
- Check that the following parts have been supplied with the appliance:-

Baskets	2
Basket Hangar	1
Basket Tray	1
Lid	1
Drain Extension	1

NOTE:

Check that the Basket Hanger has been correctly fitted. The Basket Hanger should clip over the front of the splash back and not over the flue outlet as this will restrict the operation of the flue.

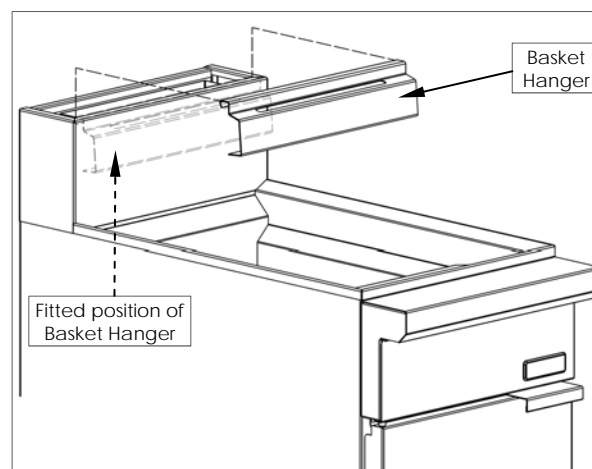

Location

1. This appliance must be installed in a suitably ventilated room to prevent dangerous build up of combustion products.
2. Installation must allow for a sufficient flow of fresh air for the combustion air supply.

Combustion Air Requirements

Natural Gas	24 m ³ /hr minimum.
LPG / Butane	24 m ³ /hr minimum.
Town Gas	24 m ³ /hr minimum.

3. Position the appliance in its approximate working position.
4. All air for burner combustion is supplied from underneath the appliance. The legs must always be fitted and no obstructions placed on the underside or around the base of the appliance, as obstructions will cause incorrect operation and / or failure of the appliance.
5. Components having adjustments protected (e.g. paint sealed) by manufacturer are only allowed to be adjusted by a qualified service agent. They are not to be adjusted by the installation person.

NOTE:

Do not obstruct or block the appliances flue. Never directly connect a ventilation system to the appliance flue outlet.

Clearances

NOTE:

Only non-combustible materials can be used in close proximity to this appliance.

To facilitate easy operation, drainage and servicing of the fryer, a minimum of 600mm clearance should be maintained at the front of the appliance.

Any gas burning appliance requires adequate clearance and ventilation for optimum and trouble-free operation. The following minimum installation clearances are to be adhered to:

	Combustible Surface	Non Combustible Surface
LH / RH Side	50mm	0mm
Rear	50mm	0mm

Assembly

This model is delivered completely assembled. Ensure that the Basket Hanger has been correctly fitted as shown on previous page. Ensure that the legs are securely attached.

NOTE:

This appliance is fitted with adjustable feet to enable the appliance to be positioned securely and level. This should be carried out on completion of the gas connection. Refer to the 'Gas Connection' section.

Gas Connection

NOTE:

ALL GAS FITTING MUST ONLY BE CARRIED OUT BY A QUALIFIED SERVICE PERSON.

1. COBRA Model Fryers do not require an electrical connection, they function totally on the gas supply only.
2. It is essential that the gas supply is correct for the appliance to be installed and that adequate supply pressure and volume are available. The following checks should therefore be made before installation:-
 - a. **The Gas Type** the appliance has been supplied for is shown on coloured stickers located above the gas entry point and next to the rating plate. Check that this is correct for the gas supply the appliance is being installed for. The gas conversion procedure is detailed in the Service Manual.
 - b. **Supply Pressure** required for this appliance is shown in the "Specifications" section of this manual. Check the gas supply to ensure that adequate supply pressure exists.

- c. **Input Rate** of this appliance is also stated on the Rating Plate fitted to the inside of the access door and in the 'Specifications' section of this manual. The input rate should be checked against the available gas supply line capacity. **Particular note should be taken if the appliance is being added to an existing installation.**

NOTE:

It is important that adequately sized piping runs directly to the connection joint on the appliance, with as few tees and elbows as possible to give maximum supply volume.

3. A suitable joining compound which resists the breakdown action of LPG must be used on every gas line connection, unless compression fittings are used.

The connection to the appliance is 3/4" BSP male.

NOTE:

A Manual Isolation Valve must be fitted to the individual appliance supply line.

4. Locate the appliance into its final operating position and using a spirit level, adjust the legs so that the unit is level and at the correct height.
5. Connect the gas supply to the appliance.
6. Check all gas connections for leakages using soapy water or other gas detecting equipment.

WARNING:

DO NOT USE A NAKED FLAME TO CHECK FOR GAS LEAKAGES.

7. Check Supply Pressure is as shown in the 'Specifications' section, 'Gas Supply Requirements' tables. (Measure at the 'Supply Pressure Test Point' (Upper - IN) on the front of the gas control valve).
8. Measure Main Burner Operating Pressure at Operating Pressure Test Point (Lower - Out) on the Gas Control Valve. Adjust if required, as shown in the 'Specifications' section, 'Gas Supply Requirements' tables.
 - Refer to the 'Gas Conversion and Specifications' section of this manual for further details.
9. **Please note that the pilot flame size is factory set and paint sealed.** Check that the pilot covers the thermocouple. If the pilot needs adjusting, this should be carried out by a qualified service agent.

Commissioning

The following commissioning checks must be carried out before the fryer is handed over for use, to ensure that the unit operates correctly and the operator(s) understand the correct operating procedure.

1. Before leaving the new installation;
 - a. Check the following functions in accordance with the operating instructions specified in the "Operation" section of this manual.
 - Light the Pilot Burner.
 - Light the Main Burner.
 - Check the Thermostat Operation (refer to the 'Operation' section of this manual).
 - b. A thermostat operation check should be carried out by filling the fryer with oil / shortening to the oil 'FILL LEVEL' mark (refer to 'Filling the Tank' in the 'Operation Section' of this manual) and setting the thermostat to 180°C. Light the pilot burner and turn main burner 'On' as shown in the 'Operation Instructions' in this manual.
 - c. Check the thermostat calibration once the oil is up to temperature. If a discrepancy is found, thermostat calibration should be referred to the supplier.
 - d. Ensure that each operator has been instructed in the areas of correct lighting, operation, and shutdown procedures for the appliance.

Initial Start-Up

- a. For first time use of the new fryer, prior to using for cooking product, fill the fryer with oil and operate for about 1 hour at the **180°C** to remove any fumes or odours which may be present in the new fryer.
 - b. Refer to the Operation Section of this manual for details on how to operate the fryer.
2. This manual must be kept by the owner for future reference and a record of ***Date of Purchase***, ***Date of Installation*** and ***Serial Number of Unit*** recorded and kept with this manual.
(These details can be found on the Rating Plate attached to the inside of the front access door).

NOTE:

If for some reason it is not possible to get the fryer to operate correctly, shut off the gas supply and contact the supplier of this unit.

Part 4 Operation

CAUTION:

- This appliance is for professional use and is only to be used by qualified persons.
- Only qualified service persons are to carry out installation, servicing or gas conversion operations.
- Components having adjustments protected (e.g. paint sealed) by the manufacturer should not be adjusted by the user / operator.

Operation Guide

1. COBRA Fryers have been designed to provide simplicity of operation and 100% safety protection.
2. Improper operation is almost impossible, however bad operation practices can reduce the oil / shortening life and produce a poor quality product. To use this fryer correctly please read the following sections carefully;
 - Filling the Tank.
 - Lighting the Pilot Burner.
 - Lighting the Main Burner.
 - Setting the Operating Temperature.
 - Draining and Cleaning.

Description of Controls

- A commercial gas fired Fryer using a single Multi Jet Target 'U' burner system.
- Available in single model type only.
- This model is fitted with a single, manual ignition, pilot burner, with Flame Failure.
- Fitted with single gas controller to control main and pilot burners.
- Mechanical Thermostat 90 - 190°C.
- Fryers feature an Over Temperature Safety Cut Out system.
- Open tank design to simplify the cleaning operation.

Single Tank CF2 Controls

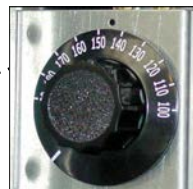

Thermostat Control Knob



Gas Control. Knob

- OFF Position.
- PILOT Flame Position.
- HIGH Flame Position.



Pilot Burner Viewing Opening.



Oil Drain Valve.

WARNING:

GREAT CARE MUST BE TAKEN BY THE OPERATOR TO USE THE FRYER SAFELY TO GUARD AGAINST THE RISK OF FIRE.

- DO NOT LEAVE THE FRYER UNATTENDED DURING OPERATION.
- DO NOT REPLENISH THE OIL (FRYING MEDIUM) IN THE FRYER WHEN THE FRYER IS **HOT**.
- DO NOT OVER FILL THE OIL (FRYING MEDIUM) IN THE FRYER ABOVE THE TOP LEVEL MARK.
- DO NOT ALLOW THE OIL (FRYING MEDIUM) IN THE FRYER TO FALL BELOW THE LOWER LEVEL MARK.
- DO NOT ALLOW THE OIL (FRYING MEDIUM) IN THE FRYER TO OVERHEAT.
- DO NOT INTRODUCE WET FOOD OR WATER INTO THE **HOT** OIL (FRYING MEDIUM).
- DO NOT USE FLAMMIBLE SOLVENTS AND CLEANING AIDS ON OR IN CLOSE PROXIMITY TO THE FRYER WHILST THE FRYER IS STILL **HOT**.

Before Use

1. Check that the gas supply is turned 'On'.
2. Check that there are no foreign articles in the tank.

Filling the Tank

WARNING:

DANGER OF FIRE EXISTS IF THE OIL LEVEL IS BELOW THE MINIMUM "LO" INDICATED LEVEL

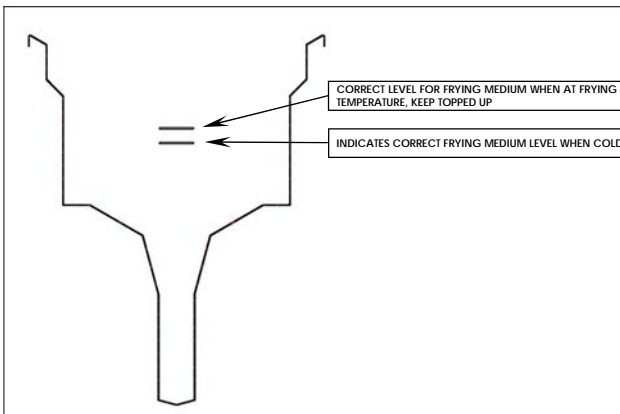

NOTE: Cobra fryers can be used with both oil and shortening.

1. Before filling the tank, always check that the drain valve, behind the access door, is closed. A locking slide is provided on this valve and this should always be locked in position during use.
 - a. **OIL** - Carefully fill fryer tank with oil until the 'FILL-LEVEL' mark is reached. The Cobra fryer will hold 18 litres of oil (32lbs shortening).
 - b. **SHORTENING** - Ideally shortening should be pre-melted prior to putting it into the tank. This is normally done in a suitable vessel on a boiling table burner. Liquefied shortening can then be poured into the tank until it reaches the 'FILL LEVEL' mark.
 - When pre-melting shortening, only heat until the shortening is just liquefied. **Do not bring up to high temperature as handling of hot shortening is dangerous.**

- If pre-melting of shortening is not possible, cut the shortening into pieces and packed down into the tank.
- Bringing the shortening up to frying temperature, when not pre-melting, should be done in two stages.

Pre-Heating:

Light the main burner and manually cycle the burner 'On' / 'Off' until the shortening has liquefied. Ideally the main burner should be cycled 'On' for 5 seconds and 'Off' for 10 seconds.

Following this procedure should allow shortening to liquefy gradually without scorching.

Once the shortening has liquefied, it can be brought up to fryer operating temperature.

NOTE:

Running burner continuously will cause shortening in contact with tank to overheat, resulting in premature oil breakdown. Never allow shortening to smoke while melting as this indicates that the temperature is too high. If the shortening starts smoking, increase the 'Off' intervals of the main burner.

Lighting the Pilot Burner

1. With the fryer tank full of frying medium, the pilot burner can be lit.
2. Check that the gas supply is turned 'On' at the mains supply.
3. Open the access door at front of fryer to access the control panel.
4. Rotate gas control knob to the pilot position and hold the gas control knob depressed.
5. Manually light the pilot burner through the Pilot Burner Viewing Opening.
6. Continue holding Gas Control Knob depressed for approx. 10 to 15 seconds after igniting pilot burner, then release, pilot burner should remain alight.
7. If the pilot burner does not ignite, repeat Items 1 to 6 above.

Lighting the Main Burner

1. Ensure pilot burner is alight, by visually checking through the Pilot Burner Viewing Opening.
2. Rotate Thermostat Control Knob to temperature required.
3. Rotate Gas Control Knob to Main Burner position.
4. Main burner will ignite automatically off the pilot burner.

NOTE:

- If main burner is turned 'On' immediately after pilot burner is lit, there will be a delay of approximately 30 seconds until the thermopile (which provides power to open the main valve) is heated up by the pilot burner.
- Main burner will not light if frying medium temperature is above thermostat set temperature.
- Turning gas control knob from pilot to main burner position will allow manual cycling of the burner 'On' and 'Off' when melting shortening.

Set the Operating Temperature

1. Temperature used for frying food is the most important aspect of fryer operation. Incorrect temperatures will result in poor product quality and will reduce the life of oil / shortening.
2. Temperature can be set from 90°C to 190°C.
3. To set the operating temperature, turn the thermostat to the desired setting.
4. Main burner will operate automatically to maintain this temperature.
5. As a safety precaution this Cobra Fryer features an Over-Temp Control which will 'Turn Off' the fryer in the event that the oil reaches over 220°C, should the thermostat fail.

NOTE:

- If fryer is not being used for short periods of time, main burner can be turned to 'Stand-by' temperature (Approx 120°C) this allows the main burner to cycle 'On' and 'Off' and maintain oil temperature just below operating temperature.

Turning Fryer to 'Pilot' or 'Off' Positions

To 'Pilot' Position.

- a. Rotate the Thermostat Control Knob to the 'Off' position.
- b. Main Burner will extinguish and 'Pilot Burner' will remain alight.

To 'Off' Position.

- a. With Thermostat Control Knob turned to 'Off', rotate Gas Control Knob to the 'O' position, the 'Pilot Burner' will extinguish.

Guide and Care of Frying Oils and Fats.

1. Prepare the food correctly. Prepare food in as nearly uniform pieces as possible and bring the food up to room temperature. Ensure food is free from excessive moisture and also excessive crumbing when 'breading' is done.
2. Preheat frying medium to recommended temperature for the particular food to be cooked and no higher - specially prepared frying mediums are recommended.
3. Frying medium should be at correct temperature for the food to be cooked before lowering food into tank. Avoid heating frying medium to any higher temperature than is recommended. Also avoid holding frying medium at frying temperature when there is no food being cooked. *Any frying medium will break down if held for long periods at frying temperatures.*
4. Lower food gradually into hot frying medium, using a wire basket, until all food pieces are submerged. **Avoid overloading basket, we recommend no more than 900g per basket or 1800g per load. Overloading will cause temperature to drop so low that a longer frying time will be needed and food will become grease soaked and un-attractive.** With a little experience you can determine what amount of food may be added to fryer without causing an excessive drop in temperature. If temperature drop is excessive, either food is too cold or there is too much food in fryer. Temperatures and cooking times quoted are based on average size batches being used in the fryer.
5. Continue cooking until outside of food is brown and crisp and pieces are cooked through.
6. Exact cooking time depends upon size of food pieces and whether food has been pre-cooked. When in doubt, test a sample and be sure.
7. Remove food from frying medium and allow to drain in the basket over the fryer.
8. Conserve excess frying medium by letting it drain back into fryer. This draining should not consume much time if fried food is to be served at its hot, crisp and flavoursome best.
9. Serve food immediately after frying.
10. Deep fried foods are at their flavour peak as soon as frying is complete. Serve them within a minute or two after they are taken from fryer. ***Fried foods should never be held.***

IMPORTANT

Should any abnormal operation like;

- ignition problems,
- abnormal burner flame,
- burner control problems,
- partial or full loss of burner flame in normal operation,

be noticed, the appliance requires IMMEDIATE service by a qualified service person and shall not be used until such service is carried out.

General

WARNING:

DO NOT USE FLAMMIBLE SOLVENTS AND CLEANING AIDS ON OR IN CLOSE PROXIMITY TO THE FRYER WHILST THE FRYER IS STILL **HOT**.

CAUTION:

Always turn off the gas supply at the mains supply before cleaning.
This appliance is not water proof.
Do not use water jet spray to clean interior or exterior of this appliance.

- To achieve the best results cleaning must be regular and thorough and all controls and mechanical parts checked and adjusted periodically by a qualified service person. If any small faults occur, have them attended to promptly.
- Don't wait until they cause a complete breakdown. It is recommended that the appliance is serviced every 6 months.
- Clean the fryer regularly. A clean fryer looks better, will last longer and will perform better.

NOTE:

- **DO NOT** use abrasive detergents, sharp scrapers, strong solvents or caustic detergents as they could corrode or damage the fryer.
- Ensure that any detergent or cleaning material have been completely removed after each cleaning.

To keep your fryer clean and operating at peak efficiency, follow the following procedures:-

WARNING:

DO NOT ATTEMPT TO MOVE THE FRYER WHILST THE FRYER IS FULL OF OIL. BEFORE ATTEMPTING TO MOVE THE FRYER, ENSURE THAT ALL THE OIL HAS BEEN DRAINED FROM THE TANK. REFER TO THE INFORMATION BELOW ON HOW TO DRAIN THE OIL FROM THE FRYER.

CAUTION:

Never drain the fryer with power or burner 'ON'
Always switch 'OFF' the fryer before draining or re-filling the tank.

Draining and Cleaning

Opening the Drain Valve

- Lift the locking slide on valve handle (Fig 1) to release valve.
- While holding the locking slide in the withdrawn position, rotate the handle anti-clockwise (Fig 2) to open the valve.
- When the valve is closed, the locking slide will drop down over the locking valve to prevent accidental opening of the valve as shown in Fig 2.

Daily Cleaning

WARNING:

HOT OIL WILL BURN - DO NOT RUSH THIS JOB.

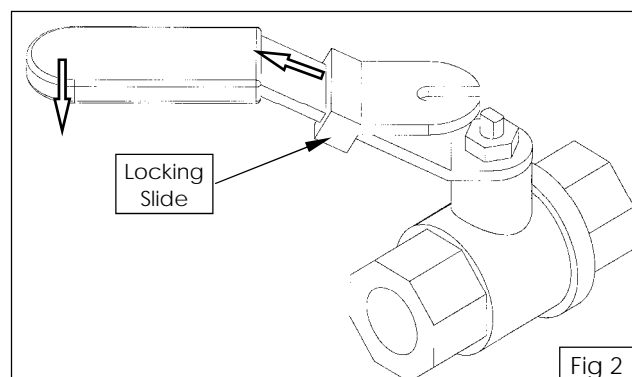
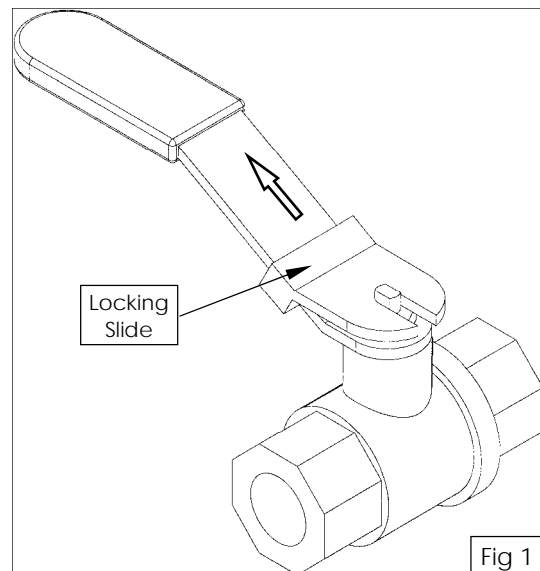

1. At the end of each day / shift, if frying schedule is heavy, frying medium should be drained and strained into a receptacle.
2. Screw on the drain extension pipe and position a suitable container and filter under the drain.
3. Slip a muslin or other suitable bag over the drain valve. Crumbs will be caught in the bag but frying medium will strain freely through bag into the receptacle.

Part 5 Cleaning and Maintenance

- Carefully open the drain valve to minimise splashing, and take care not to overfill the container.
- Use a drain stick, to stir up any solid medium into the top medium to melt it.
- When the tank is empty, use a small vessel with a handle as a ladle and dip into the hot frying medium from receptacle and pour vigorously around sides and bottom of the tank to wash out crumbs and particles adhering to them. Continue to dip and pour until all crumbs are washed down and into the filter bag.
- Open drain valve fully, check for any particles or crumb residue lodged in the valve. Clean out with a stiff nylon brush. Do not use wire brush or metal rods as these damage the seating in the valve and will cause valve leakage.
- If the obstruction in the valve cannot be removed with a brush, use a wooden probe.
- Clean the control panel with a damp cloth lightly moistened with a solution of mild detergent and water. Wipe dry with a clean dry cloth.
- Once the daily cleaning operation is completed, close the valve and pour the frying medium back into the tank and continue the days work. Straining takes less time than frying one load of potatoes and will pay dividends in food quality and saving of frying medium.
- Empty the fryer and rinse thoroughly with water. Use a 1 part vinegar to 15 parts water solution to rinse the tank and neutralise any cleaner residue. Use a weaker solution of up to 1 part to 25 water if this proves unsuitable for the cleaner being used.
- Rinse the tank thoroughly with water, drain and dry.
- Refill the tank with new filtered frying medium.

Stainless Steel Surfaces

- With the tank(s) drained, cleaned and dried as shown above, clean the exterior of the fryer with hot water, a mild detergent solution and a soft cloth. Note that the thermostat control knobs can be removed to allow cleaning of the thermostat panel.
- Dry all components thoroughly with a dry cloth and polish with a soft dry cloth.
- To remove any discolouration, use an approved stainless steel cleaner or stainless steel wool. Always rub in the direction of the grain.

Periodic Maintenance

WARNING:

DO NOT ATTEMPT TO MOVE THE FRYER WHILST THE FRYER IS FULL OF OIL.

BEFORE ATTEMPTING TO MOVE THE FRYER, ENSURE THAT ALL THE OIL HAS BEEN DRAINED FROM THE TANK. REFER TO THE INFORMATION ON THE PREVIOUS PAGE ON HOW TO DRAIN THE OIL FROM THE FRYER.

NOTE:

All maintenance operations should only be carried out by a qualified service person.

To achieve the best results cleaning must be regular and thorough and all controls and mechanical parts should be checked and adjusted periodically by a qualified service person. If any small faults occur, have them attended to promptly. Don't wait until they cause a complete breakdown. It is recommended that the appliance is serviced every 6 months.

Weekly Cleaning

NOTE:

If the fryer usage is very high, we recommend that the weekly cleaning procedure is carried out on a more frequent basis.

- Proceed as for "Daily Cleaning" to drain and filter the tank. Do not refill the tank with frying medium until it has been cleaned as shown below.
- Fill the fryer with cold water to the normal fill level and add a high quality commercial cleaner that has been specifically formulated for fryers. All purpose cleaners are not recommended.

NOTE:

Never use a caustic or lye solution, as this will leave a fat destroying film on the tank.

- Heat the water to approximately 80-90°C.
- Clean the fryer baskets by simply immersing them in the cleaning solution. Allow the fryer to soak for 5-10 minutes or as directed on the cleaner instructions. Remove the baskets and turn OFF the main burner.
- Scrub the baskets and fryer tank lightly, but vigorously with a stiff nylon bristle brush to remove any remaining deposits. **DO NOT use a wire brush, as this will scratch the sides.**

Gas Conversion Procedure

CAUTION:

Ensure that the Unit is isolated from the gas supply before commencing servicing

NOTE:

- These conversions should only be carried out by qualified service persons. All connections must be checked for leaks before re-commissioning the appliance.
- For all relevant information and specifications refer to the table at the end of this section.
- Flexible Hose Connection;

If a Gas Hose assembly is used to connect this appliance, the hose and all fittings must have a minimum 3/4" (Natural Gas) or 1/2" (LPG) inside bore diameter to ensure gas flow rate capacity required by this appliance is achieved.

This must be verified by operating pressure testing at maximum gas supply demand condition.

The Gas Hose assembly should also be classified for use in the commercial kitchen conditions, the appliance will be used in.

Recommended Gas Hose Assembly Specification:

- AS/NZS 1869 Class B or D compliant or equivalent, that meets the following requirements:-

Class	B	D
Max Working Pressure at 23 ± 2°C	7.0 kPa	2.6 MPa
Working Temperature Range	- 20°C to + 125°C	
Resistance to Oil	Oil resistant lining and cover.	

1. Ensure that the gas supply has been turned 'Off'.
2. Open the front door of the fryer to access the main burner and pilot burner injectors.
3. Disconnect 2 wires from the Thermostat to the Gas Control Valve.
4. Disconnect 2 wires from the Overtemp at the electrical connector.

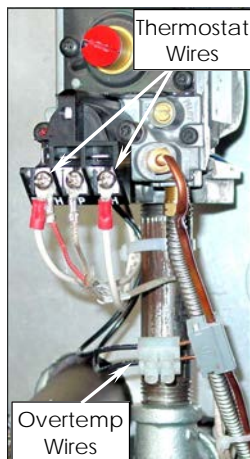

5. Cut and remove any cable ties as required
6. Disconnect the flexi tube gas connection at the top of the Gas Control Valve.

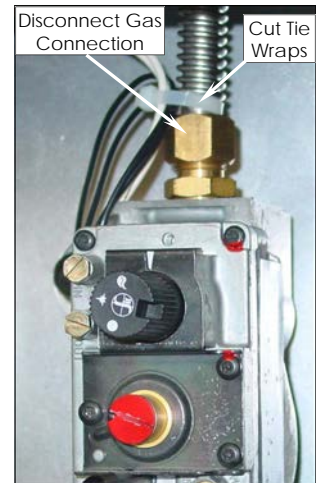

7. Undo and remove the 4 screws securing the front of the burner to the burner box.
8. Pull the burner towards the front of the fryer and downwards to remove.

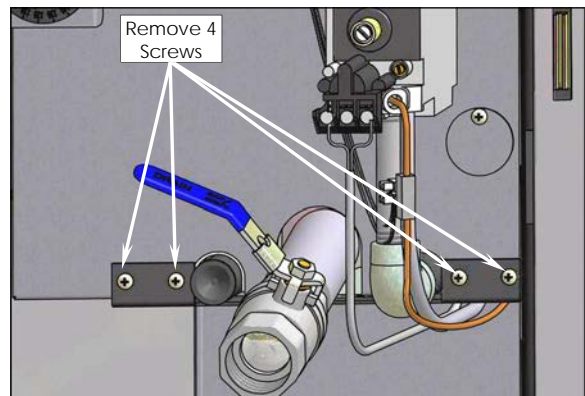

9. Remove the Burner Assembly to a workbench.

CAUTION:

Do not bend the Flame Deflector Plates.

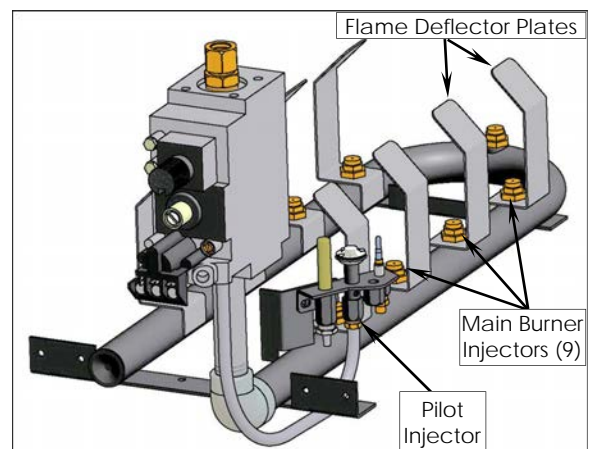

Main Burner Injectors

1. To remove Main Burner Injectors, use a spanner to prevent Injector Insert from turning while removing injector.
2. Replace with the correct size injectors.
3. Refit burner assembly back into burner box.

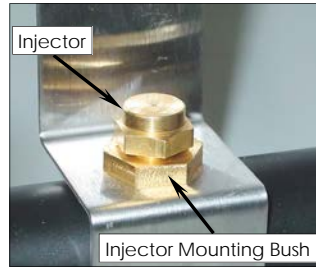

Pilot Burner Injectors

1. Unscrew pilot supply tube from pilot burner and remove pilot injector.
2. Determine correct sized pilot injectors for the corresponding gas from the table overleaf.
3. Fit correct sized injector into pilot burner and re-connect gas supply tube to the pilot burner.

Supply Pressure Check

1. Remove the blanking screw and connect a manometer to the Supply Pressure Test Point ('IN') on Gas Control Valve.
2. Turn 'On' the gas supply and ensure that the pressure is within specifications shown in 'Gas Specifications Table' at rear of this section.

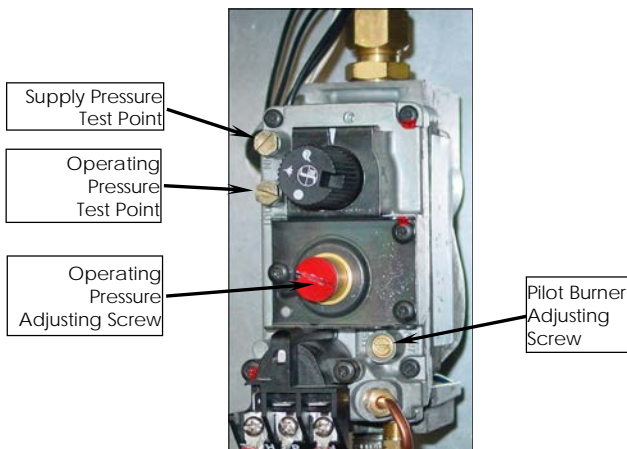

Main Burner Operating Pressure Adjustment

1. Connect a manometer to Operating Pressure Test Point ('OUT') on the gas control valve.
2. Remove slotted cap to reveal **Operating Pressure Adjusting Screw**.
3. Light Main Burner and turn Operating Pressure Adjusting Screw to obtain correct burner pressure for type of gas being used. Refer to **Gas Specifications Table** at rear of this section.
4. Remove manometer from Operating Pressure Test Point and refit blanking screw.
5. Refit slotted cap to screw adjustment point.

Town Gas Only

NOTE:

For Town Gas application, Gas Control Valve - Operating Pressure Adjusting Screw should be replaced with the Knock Out Plug supplied in Town Gas Kit and the operating pressure adjusted at the External Gas Pressure Regulator. Both the Knock Out Plug and External Regulator are supplied in the Town Gas Conversion Kit.

1. Remove slotted cap from regulator.
2. Turn 'On' gas supply and appliance.
3. Adjust pressure adjusting screw to achieve correct burner operating pressure.

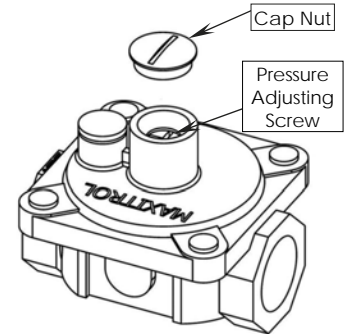

NOTE: Measure operating pressure at the Gas Control Valve 'Out' test point with burner operating.

4. Verify operating pressure remains correct (Re-adjust regulator if required).
5. Screw cap nut back onto regulator.

Pilot Burner Flame Adjustment

1. Once main burner operating pressure has been set, adjust pilot burner supply so that pilot flame impingement onto thermocouple and thermopile is correct and main burner pilot flame ignites main burner satisfactorily.
2. Adjust pilot flame size by adjusting **Pilot Burner Adjusting Screw**. Pilot burner flame should be approximately 1" long for main burner ignition. Anti-clockwise rotation of adjustment screw will increase size of pilot flame.

Gas Type Identification Label

On completion of gas conversion, replace gas type identification label located at:-

- Rear of appliance, above gas connection.
- Beside the Rating Plate.

Commissioning

Before leaving the converted installation;

1. Check all gas connections for leakages using soapy water or other gas detecting equipment.

WARNING:

DO NOT USE A NAKED FLAME TO CHECK FOR GAS LEAKAGES.

2. Check the following functions in accordance with the operating instructions specified in the 'Operation' section of this manual.
 - Light the Pilot Burner.
 - Light the Main Burner.
 - Check the Thermostat operation.
 - Ensure that all the controls operate correctly.

NOTE: If it is not possible to get the fryer to operate correctly, shut Off the gas supply and contact the supplier of this appliance.

Gas Specifications

- Australia:

	Natural Gas	LP Gas (Propane)
Main Burner Injectors	Ø 1.55mm	Ø 0.95mm
Pilot Burner Injectors	0.62	0.35
Pilot Screw Adjustment	Full Out (CCW)	1½ turns out (CCW)
Burner Operating Pressure	0.90 kPa (*) (9.0 mbar)	2.50 kPa (*) (25 mbar)
Supply Pressure	1.13 - 2.0 kPa	2.75 - 3.0 kPa

- New Zealand:

	Natural Gas	LP Gas / Butane
Main Burner Injectors	Ø 1.55mm	Ø 0.90mm
Pilot Burner Injectors	0.62	0.35
Pilot Screw Adjustment	Full Out (CCW)	1½ turns out (CCW)
Burner Operating Pressure	0.90 kPa (*) (9.0 mbar)	2.50 kPa (*) (25 mbar)
Supply Pressure	1.13 - 2.0 kPa	2.75 - 3.0 kPa

- United Kingdom:

Appliance Classification:

Category: I1_{2H3P} (20, 37). Flue Type: A₁.

	Natural Gas (G20)	Propane (G31)
Main Burner Injectors	Ø 1.55mm	Ø 0.95mm
Pilot Burner Injectors	0.45	0.30
Pilot Screw Adjustment	Full Out (CCW)	1½ turns out (CCW)
Burner Operating Pressure	0.90 kPa (*) (9.0 mbar)	2.50 kPa (*) (25 mbar)
Supply Pressure	20 mbar	37 mbar

- All Other Markets:

	Natural Gas	LP Gas (Propane)	LP Gas / Butane	Town Gas (**)
Main Burner Injectors	Ø 1.55mm	Ø 0.95mm	Ø 0.90mm	Ø 2.60mm
Pilot Burner Injectors	0.62	0.35	0.35	0.75
Pilot Screw Adjustment	Full Out (CCW)	1½ turns out (CCW)	1½ turns out (CCW)	Full Out (CCW)
Burner Operating Pressure	0.90 kPa (*) (9.0 mbar)	2.50 kPa (*) (25 mbar)	2.50 kPa (*) (25 mbar)	0.39 kPa (*) (3.9 mbar)
Supply Pressure	1.13 - 2.0 kPa	2.75 - 3.0 kPa	2.75 - 3.0 kPa	0.75 - 1.5 kPa

NOTE:

(*) Measure Burner Operating Pressure at Operating Pressure Test Point (Lower - Out) on Gas Control Valve, this is to be carried out with Main Burner operating. Refer to information shown in this section for further details.

(**) TOWN GAS Only - Gas Control Valve - Operating Pressure Adjusting Screw should be replaced with the Knock Out Plug supplied in Town Gas Kit and the operating pressure adjusted at the External Gas Pressure Regulator. Both the Knock Out Plug and External Regulator are supplied in the Town Gas Conversion Kit.

Replacement Parts List

IMPORTANT:

Only genuine qualified replacement parts should be used for the servicing and repair of this appliance. The instructions supplied with the parts should be followed when replacing components.

For further information and servicing instructions, contact your nearest qualified service branch (contact details are as shown on the reverse of the front cover of this manual).

When ordering replacement parts, please quote the part number and the description as listed below. If the part required is not listed below, request the part by description and quote the model and serial number which is on the rating plate.

Controls

236835	Main Burner Assembly (Includes Injector Mounting Bush & Burner Deflectors).		
018090K	Pilot Kit (Including Nat / LPG Injectors).		
030155	Main Injector	Nat Gas	Ø 1.55mm.
030095	Main Injector	LPG (Propane)	Ø 0.95mm.
030090	Main Injector	LPG (NZ) Butane	Ø 0.90mm.
030260	Main Injector	Town Gas	Ø 2.60mm.
018091	Pilot Injector	Nat Gas	0.62 (Non UK).
018092	Pilot Injector	LPG / Butane	0.35 (Non UK).
018972	Pilot Injector	Nat Gas (G20)	0.45. (UK Only).
018971	Pilot Injector	Propane (G31)	0.30. (UK Only).
026393	Pilot Injector	Town Gas	0.75.
018093	Thermopile.		
018094	Thermocouple Interrupted.		
236801	Thermostat MV Fryer, 90-190°C.		
236848	Knob, 100 - 190°C.		
018022K	Overtemp Control Kit.		
018089K	Gas Control Valve Kit.		

General

236768	Basket Support Rack.
236742	Basket Hangar.
018019	Fryer Basket.
227856	Door Magnet.
227466	Door Catch Receiver.
236795	Drain Valve.
018147	Drain Extension.
236769	Adjustable Leg - 150mm.
229674	Rear Roller Assy.
236933	Fryer Lid.

Optional Extra

18176	Drain Stick (Optional Extra Only).
-------	------------------------------------

Gas Conversion Kits

Kit Part No.	Gas Type to Convert to	Markets
236934	Gas Conversion - NAT GAS	AU / NZ / XP
236935	Gas Conversion - LPG (PROPANE)	AU / XP (LPG)
236936	Gas Conversion - LPG / BUTANE	NZ / XP (Butane)
236937	Gas Conversion - TOWN GAS	AU / NZ / XP
237021	Gas Conversion - NAT GAS (G20)	UK
237022	Gas Conversion - PROPANE (G31)	UK

