

## Load cell PR 6212, converter Connexx<sup>®</sup> for maximum corrosion resistance

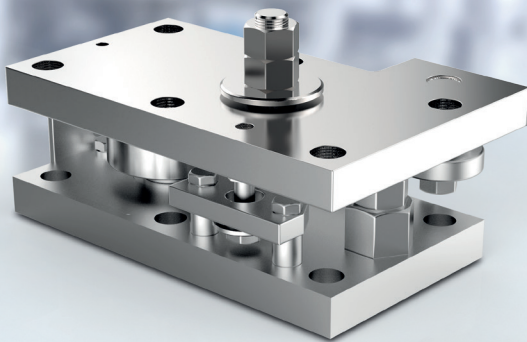

### ⓘ Load cell PR 6212 benefits

- Maximum corrosion resistance
- High-temperature version available for up to 180 °C
- Easy and failure-free installation using the mounting kit PR 6012

### ⓘ Mounting kit PR 6012 benefits

- Integrated jack-up and dummy function
- Low installation height



Digital Assistance  
Technology



*The load cell PR 6212 is a state-of-the-art product. This corrosion-resistant load cell has a compact design and also features high heat resistance. Its long product lifetime minimises downtime and ensures safer and more reliable processes in the chemical and steel industry.*

### Corrosion resistance and precision for demanding applications

- ⓘ Stainless steel 1.4418, unique in weighing technology, ensures **maximum corrosion resistance**. The PR 6212 is **also available with protective coating** for use in extremely aggressive environments.
- ⓘ The perfectly coordinated combination of the load cell PR 6212 and mounting kit PR 6012 meets all precision and handling requirements. The **inverted installation** provides additional corrosion protection for the load cell and **is simple and failure-free**.
- ⓘ The compact design **ensures a low system height** and allows for easy retrofitting of weighing technology.

## Less corrosion, more cost-efficiency

The combination of the load cell PR 6212 and mounting kit PR 6012 makes quick and easy installation possible and facilitates consistently reliable and precise measurement results in the chemical and steel industry.



Scan the QR code and watch our video showing the load cell PR 6212 in endurance test.

Laser labelling for long-lasting product identification

Compatible with PR 6211 and PR 6011

Optional: high-temperature version for up to 180 °C



Highest corrosion resistance stainless steel 1.4418 – unique in weighing technology

Additional corrosion protection thanks to smooth finish and lack of horizontal surfaces

Compact design for easy installation

Optional: protective coating for extremely aggressive environments

## Combined for reliable installation: PR 6212 and PR 6012 as a complete solution

The load cell PR 6212 is not only fully compatible with all mounting kits from the PR 6012 range but also with the previous PR 6011 range. The innovative complete solution ensures failure-free and efficient installation. Thanks to the integrated jack-up function there is no need for external lifting devices and even a load cell dummy is no longer required.

Large mounting holes for flexible installation

Optional: reinforced lift-off protection for lift-off forces up to 45 kN

Inverted installation of the load cell provides additional corrosion protection

Integrated constrainer to protect against horizontal forces

Integrated lift-off protection with extended horizontal tolerances absorbs temperature fluctuations

Integrated jack-up and dummy function for easy installation of the load cell

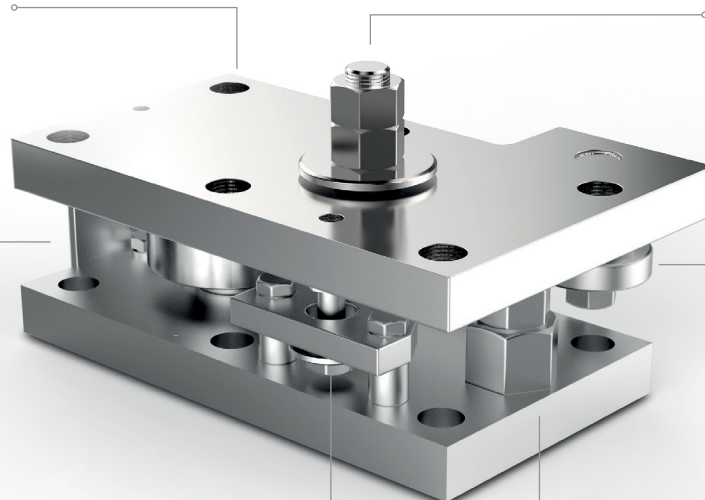



# Load cell technical specifications

## PR 6212 technical data

Parameter	Description	Abbr.	PR 6212/.. LT <sup>4)</sup> (high-temperature load cell)	PR 6212/.. C1 <sup>1)</sup> PR 6212/.. C1E <sup>2)</sup> PR 6212/.. C1-L <sup>3)</sup> (load cell with protective coating)	Unit
Accuracy class			0,25	0,04	% E <sub>max</sub>
Minimum dead load	lowest limit of specified measuring range	E <sub>min</sub>	0	0	% E <sub>max</sub>
Maximum capacity	highest limit of specified measuring range	E <sub>max</sub>	0,5; 1; 2; 3; 5	0,5; 1; 2; 3; 5; 10	t
Safe load limit	upper limit of measurements	E <sub>lim</sub>	150	150	% E <sub>max</sub>
Destructive load	danger of mechanical destruction	E <sub>d</sub>	>300	>300	% E <sub>max</sub>
Minimum LC verification	minimum load cell scale interval, V <sub>min</sub> = E <sub>max</sub> /Y	Y	-	5000	
Rated output	relative output at maximum capacity	C <sub>n</sub>	2	2	mV/V
Tolerance on rated output	permissible deviation from rated output C <sub>n</sub>	d <sub>c</sub>	<1,5	<0,25	% C <sub>n</sub>
Zero output signal	load cell output signal under unloaded condition	S <sub>min</sub>	0±2	0±2	% C <sub>n</sub>
Reproducibility	max. change in load cell output for repeated loading	ε <sub>R</sub>	<0,1	<0,01	% C <sub>n</sub>
Creep	max. change of output signal at E <sub>max</sub> during 30 minutes	d <sub>cr</sub>	<0,1	<0,035	% C <sub>n</sub>
Linearity deviation <sup>5)</sup>	deviation from best straight line through zero	d <sub>lin</sub>	<0,25	<0,03	% C <sub>n</sub>
Hysteresis <sup>5)</sup>	max. difference in LC output between loading and unloading	d <sub>hy</sub>	<0,25	<0,035	% C <sub>n</sub>
Temperature effect on S <sub>min</sub>	max. change of S <sub>min</sub> per 10 K over BT referred to C <sub>n</sub>	TK <sub>Smin</sub>	<0,1	<0,028	% C <sub>n</sub> /10 K
Temperature effect on C <sup>5)</sup>	max. change of C per 10 K over B <sub>T</sub> referred to C <sub>n</sub>	TK <sub>C</sub>	<0,07	<0,02	% C <sub>n</sub> /10 K
Input impedance	between supply terminals	R <sub>LC</sub>	1200 ±200	650 ±6	Ω
Output impedance	between measuring terminals	R <sub>O</sub>	1200 ±6	610 ±1	Ω
Insulation impedance	between measuring circuit and housing at 100 V <sub>DC</sub>	R <sub>IS</sub>	>5000	>5000	M Ω
Insulation voltage	between circuit and housing (PR 6212/..E only)		-	500	V
Recommended supply voltage	to hold the specified performance	B <sub>U</sub>	4...24	4...24	V
Max. supply voltage	permissible for continuous operation without damage	U <sub>max</sub>	32	32	V
	PR 6212/..E	U <sub>max</sub>	-	25	V
Nominal ambient temp. range	to hold the specified performance	B <sub>T</sub>	-10...+155	-10...+40	°C
Service temperature range	permissible for continuous operation without damage	B <sub>Tu</sub>	-30...+180	-30...+95	°C
Storage temperature range	without electrical and mechanical stress	B <sub>Tl</sub>	-40...+180	-40...+95	°C
Permissible inclination	permissible inclination whilst maintaining the specified measurement accuracy		1	1	angle in °
Vibration resistance	resistance against oscillations (IEC 60068-2-6-Fc)		20 g, 100 h, 10...150 Hz	20 g, 100 h, 10...150 Hz	
Ambient pressure impact	influence of ambient air pressure on S <sub>min</sub>	PK <sub>Smin</sub>	≤70	≤60	g/kPa
Nominal deflection	elastic deformation under maximum capacity	s <sub>nom</sub>	<0,2	<0,2	mm
Material (sensor)			1.4542 (DIN EN 10088-3)	1.4418 (DIN EN 10088-3)	
Protection class			according to IEC 529 - PR 6212: IP68*/IP69 - Connexx®: IP65 / IP 68**		
Cables			robust, flexible, shielded, length: 5 m		
			PR 6212/.. LT PFA, colour: red, Ø 5 mm, 4 x 0,382 mm <sup>2</sup>	PR 6212/.. C1 TPE, colour: grey, Ø 5 mm, 4 x 0,355 mm <sup>2</sup>  PR 6212/C1E TPE, colour: blue, Ø 5 mm, 4 x 0,382 mm	
Bending radius			fixed installation ≥50 mm, flexible installation ≥150 mm		

<sup>1)</sup> C1 = load cell with C1 measurement accuracy | <sup>2)</sup> C1-L = load cell with C1 measurement accuracy and special protective coating | <sup>3)</sup> C1E = load cell with C1 accuracy for Ex applications | <sup>4)</sup> LT = high-temperature version  
<sup>5)</sup> The data for Non-linearity, hysteresis and TKC are typical values. For OIML R60 or NTEP approved load cells the sum of these values is within the permissible cumulative error limits.

Connexx®					
Nominal ambient temp. range	To hold the specified performance	B <sub>T</sub>	-10 ... +40		°C
Usable temperature range	Permissible for continuous operation without damage	B <sub>Tu</sub>	-30 ... +60		°C
Storage temperature range	Without electrical and mechanical stress	B <sub>Tl</sub>	-30 ... +70		°C

\* The load cell can be submerged in water at a depth of 1.5 m for 10,000 hours. | \*\* The module can be submerged in water at a depth of 1.5 m for 100 hours.

## Mounting kit technical specifications

PR 6012 technical data										
Maximum capacity of load cell PR 6212	Mounting kit/ accessories	Material	Description/comments	Mounting screws	Installation height	Max. permissible horizontal force (kN)	Horizontal destructive force [kN]	Max. permissible lift-off force (kN)	Maximum permissible eccentricity	Max. permissible vertical load without load cell
500 kg - 10 t	PR 6012/01 N, S	Steel S235, stainless steel 1.4301 (AISI 304)	Mini FLEX	M8	80 mm	/	/	/	+/- 4 mm	/
	PR 6012/31 N, S		Mini FLEXLOCK	M8	80 mm	5	10	/	+/- 4 mm	/
	PR 6012/41 N, S		Mini FLEXLOCK; reinforced constrainer	M12	80 mm	20	50	/	+/- 4 mm	/
500 kg - 10 t	PR 6012/02 N, S	Steel S235, stainless steel 1.4301 (AISI 304)	Maxi FLEX	M8	80 mm	/	/	10	+/- 4 mm	5 t
	PR 6012/32 N, S		Maxi FLEXLOCK	M8	80 mm	5	10	10	+/- 4 mm	5 t
	PR 6012/42 N, S		Maxi FLEXLOCK; reinforced constrainer	M12	80 mm	20	50	10	+/- 4 mm	5 t
	PR 6012/53 S	Stainless steel A2-70	Optional extension of lift-off protection (M12) for PR 6012/31 and PR 6012/32	/	/	/	/	25	-	/
	PR 6012/54 S		Optional extension of lift-off protection (M16) for PR 6012/41 and PR 6012/42	/	/	/	/	45	-	/
	PR 6012/63 S	Stainless steel 1.4301 (AISI 304)	Pivot for PR 6212/ 500 kg - 10 t	M8	80 mm	12	70	/	/	/

## Converter Connexx®



Fitted with the converter Connexx®, the load cell PR 6212 offers a whole host of possibilities:

- The digital version guarantees fast signalling times for reliable dosing processes.
- Thanks to the use of field bus communication, the cable junction box is no longer needed.
- The standard interface CANopen ensures straightforward installation and calibration.
- CANopen allows for extra-long communication paths of up to 200 m.
- Weight values can also be generated individually – per load cell – meaning that defective load cells can be identified more easily.

## Mounting kit PR 6012/X1 dimensional drawings

The mounting kit PR 6012/X1 was developed for use in the toughest conditions. The inverted installation of the load cell combined with the special high-quality material of the mounting kit make a complete solution capable of withstanding chemically aggressive, corrosive environments. The measurement results are also not affected by temperature fluctuations thanks to large lateral tolerances and the integrated horizontal constrictor. What's more, the mounting kit was designed to be especially easy and reliable to install.

PR 6212

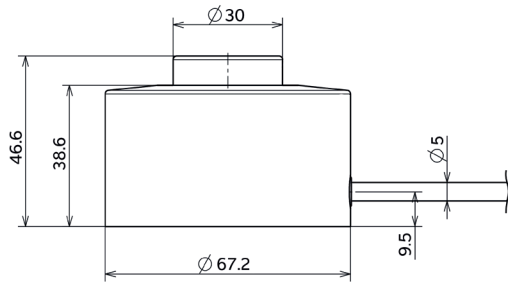

Converter Connexx®

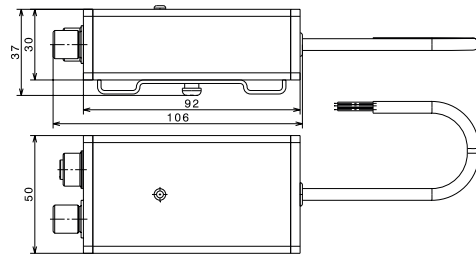

PR 6012/63 S

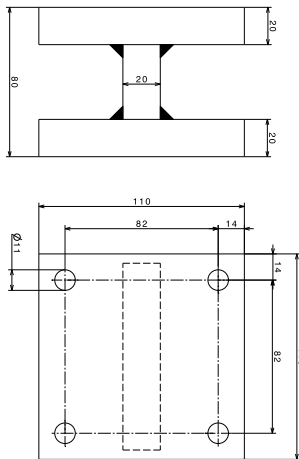

PR 6012/01 N, S

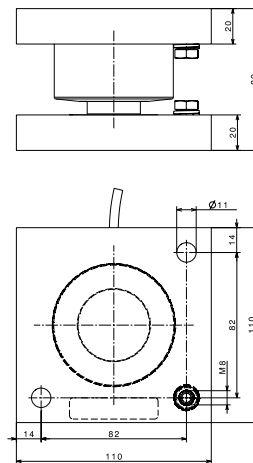

PR 6012/31 N, S

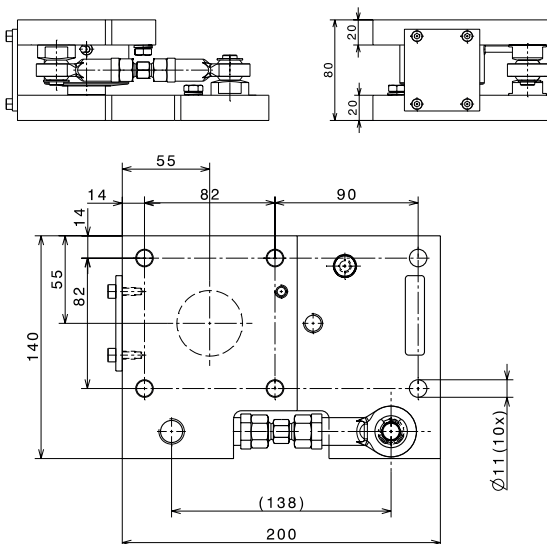

PR 6012/41 N, S

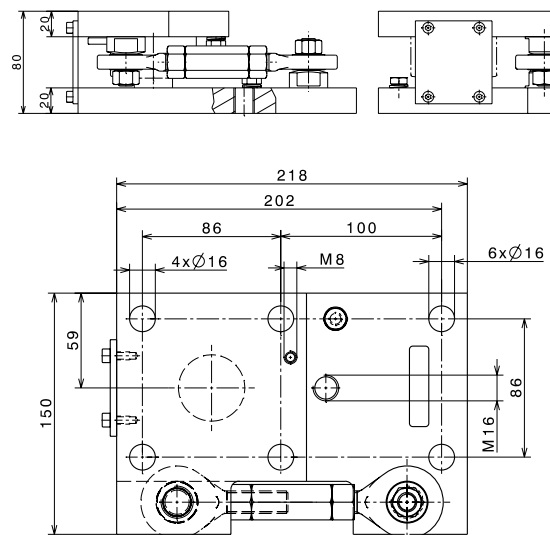

## Mounting kit PR 6012/X2 dimensional drawings

In addition to the features of the PR 6012/X1 the mounting kit PR 6012/X2 range also has extensive additional functions that make installation and operation of the weighing technology easier. The integrated jack-up function eliminates the need for external lifting devices, while the integrated dummy function makes easy installation possible – without damaging the sensitive load cell. Lift-off protection up to 45 kN effectively prevents the vessel from tipping.

PR 6012/02 N, S

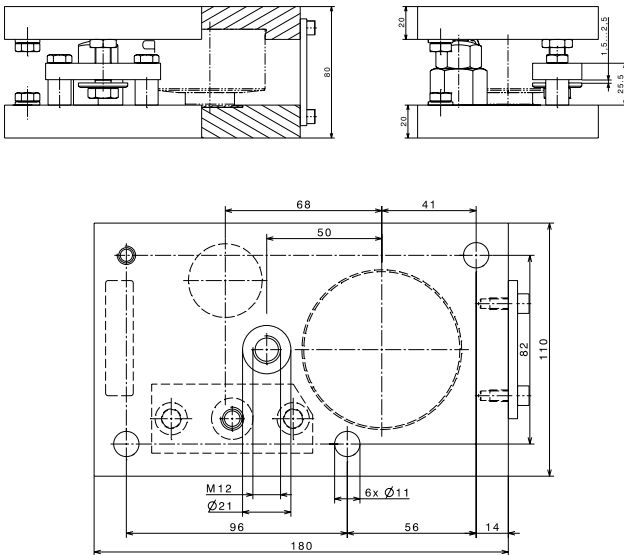

PR 6012/32 N, S

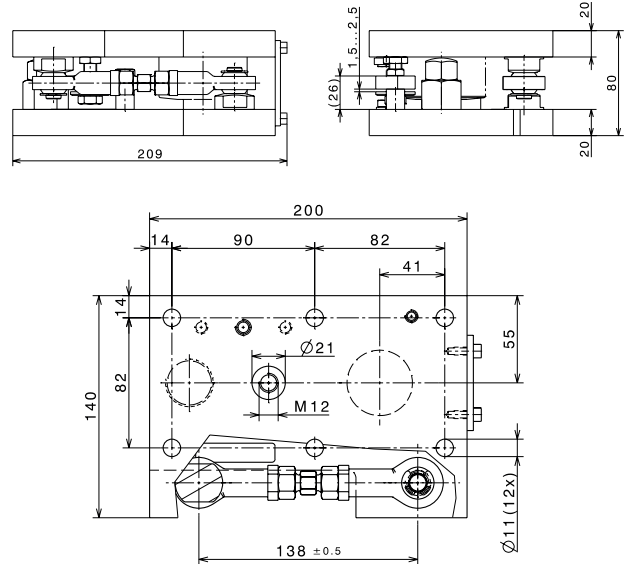

PR 6012/42 N, S

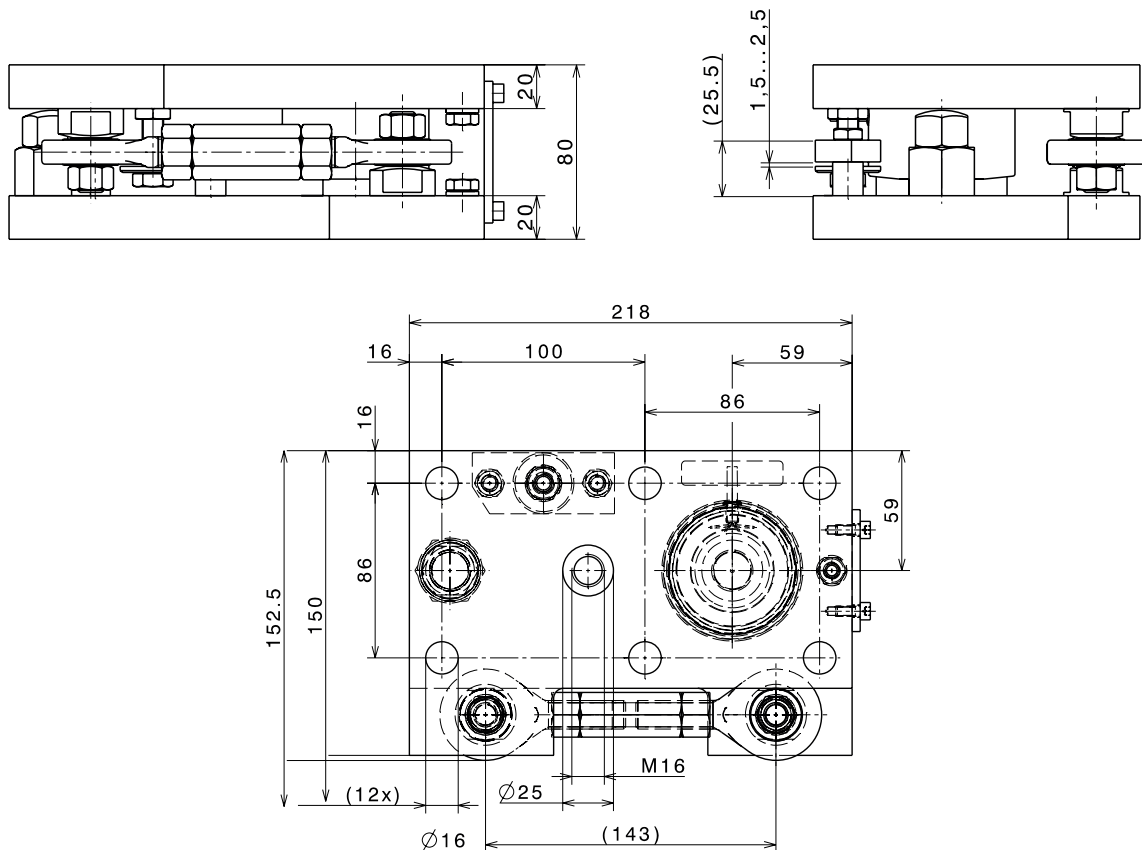

# Approvals

## Scope of validity:

PR 6212/... C1E (500 kg ... 10 t)

Certificates for the load cell			
Zone	Labeling	Certificate number	for
0 and 1	II 1G Ex ia IIC T6 Ga Ex ia IIC T6 Ga OEx ia IIC T6 (")	BVS 16 ATEX E 005 IECEX BVS 16.0005	PR 6212/..E only
20 and 21	II 1D Ex ta IIIC T160°C Da Ex ta IIIC T160°C Da Ex ta IIIC T160°C X (")	TÜV 03 ATEX 2301 X IECEX TUN 17.0025X	PR 6212/..E only
2	II 3G Ex nA IIC T6 Gc 2 Ex nA IIC T6 X (")	Certificate manufacturer	all PR 6212 except LT version
22	II 3D Ex tc IIIC T85 °C Dc Ex tc IIIC T6 X (")	Certificate manufacturer	all PR 6212 except LT version
	IS / I,II,III / 1 / ABCDEFG / T4A Ta= -30°C to 70°C; T5 Ta= -30°C to 55°C - 4012 101 5688; Entity NI / I,II,III / 2 / ABCDEFG / T4A Ta= -30°C to 70°C; T5 Ta= -30°C to 55°C - 4012 101 5688; NIFW	FM - Original project ID: 3001200	all PR 6212 except LT version
	IS / I,II,III / 1 / ABCDEFG / T4A Ta= -30°C to 70°C; T5 Ta= -30°C to 55°C - 4012 101 5688; Entity NI / I / 2 / ABCD / T4A Ta= -30°C to 70°C; T5 Ta= -30°C to 55°C - 4012 101 5688; NIFW DIP / II,III / 2 / EFG / T4A Ta= -30°C to 70°C; T5 Ta= -30°C to 55°C - 4012 101 5688; NIFW	FM - Canada project ID: 3053046	all PR 6212 except LT version
	Ambient temperature in Ex-Area -30... +55 °C		
	(") only with approval TP TC 012 (TRCU 012) -52...+55°C		

## Ordering information

Load cell PR 6212					
Type	Order number	Type	Order number	Type	Order number
PR 6212/500 kg C1	940521201150	PR 6212/2 t C1	940521201220	PR 6212/5 t C1	940521201250
PR 6212/500 kg C1E	940561201150	PR 6212/2 t C1E	940561201220	PR 6212/5 t C1E	940561201250
PR 6212/500 kg C1-L	940581201150	PR 6212/2 t C1-L	940581201220	PR 6212/5 t C1-L	940581201250
PR 6212/500 kg LT	940541201150	PR 6212/2 t LT	940541201220	PR 6212/5 t LT	940541201250
PR 6212/1 t C1	940521201210	PR 6212/3 t C1	940521201230	PR 6212/10 t C1	940521201310
PR 6212/1 t C1E	940561201210	PR 6212/3 t C1E	940561201230	PR 6212/10 t C1E	940561201310
PR 6212/1 t C1-L	940581201210	PR 6212/3 t C1-L	940581201230	PR 6212/10 t C1-L	940581201310
PR 6212/1 t LT	940541201210	PR 6212/3 t LT	940541201230		

Load cell PR 6212, converter Connexx®		
Type	Description	Order number
PR 6212/DIGITAL KIT	The converter Connexx® can only be ordered with the above-mentioned load cells from the PR 6212 series. When ordering, both order numbers need to be given.	940511200000

### Additional information:

The converters Connexx® can be used with the Indicator X3.

To do this, the indicator X3 must be equipped with a CANopen interface card PR 5510/05 (940535510051).



## Load cell PR 6212, converter Connexx® – application sets

Type	Description	Order number
PR 6154/03	Application set for 3 load cells. Includes: 2 × PR 6155/05, 1 × PR 6152/25, 1 × PR 6153/99	940536154031
PR 6154/04	Application set for 4 load cells. Includes: 3 × PR 6155/05, 1 × PR 6152/25, 1 × PR 6153/99	940536154041

## Load cell PR 6212, converter Connexx® – load cell accessories

Type	Description	Order number
PR 6152/10	Connection cable between Connexx® and X3 (10 m)	940536152101
PR 6152/25	Connection cable between Connexx® and X3 (25 m)	940536152251
PR 6152/40	Connection cable between Connexx® and X3 (40 m)	940536152401
PR 6153/98	Divided cable gland	940536153981
PR 6153/99	Terminal resistor for Connexx®, M12	940536153991
PR 6155/05	Connection cable between Connexx® and Connexx® (5 m)	940536155051
PR 6155/10	Connection cable between Connexx® and Connexx® (10 m)	940536155101

## Mounting kit PR 6012

### Mounting kits without integrated constrainer

Type	Description	Order number
PR 6012/01 N	Mounting kit Mini FLEX for PR 6212/500 kg – 10 t	940536012011
PR 6012/01 S	Mounting kit Mini FLEX for PR 6212/500 kg – 10 t, stainless steel	940536012012

### Mounting kits with integrated constrainer

Type	Description	Order number
PR 6012/31 N	Mounting kit Mini FLEXLOCK for PR 6212/500 kg – 10 t	940536012311
PR 6012/31 S	Mounting kit Mini FLEXLOCK for PR 6212/500 kg – 10 t, stainless steel	940536012312
PR 6012/41 N	Mounting kit Mini FLEXLOCK for PR 6212/500 kg – 10 t	940536012411
PR 6012/41 S	Mounting kit Mini FLEXLOCK for PR 6212/500 kg – 10 t, stainless steel	940536012412

### Mounting kit with additional functions and without integrated constrainer

Type	Description	Order number
PR 6012/02 N	Mounting kit Maxi FLEX for PR 6212/500 kg – 10 t	940536012021
PR 6012/02 S	Mounting kit Maxi FLEX for PR 6212/500 kg – 10 t, stainless steel	940536012022

### Mounting kit with additional functions and integrated constrainer

Type	Description	Order number
PR 6012/32 N	Mounting kit Maxi FLEXLOCK for PR 6212/500 kg – 10 t	940536012321
PR 6012/32 S	Mounting kit Maxi FLEXLOCK for PR 6212/500 kg – 10 t, stainless steel	940536012322
PR 6012/42 N	Mounting kit Maxi FLEXLOCK for PR 6212/500 kg – 10 t	940536012421
PR 6012/42 S	Mounting kit Maxi FLEXLOCK for PR 6212/500 kg – 10 t, stainless steel	940536012422
PR 6012/53 S	Optional extension of lift-off protection (M12) for PR 6012/31 and PR 6012/32	940536012532
PR 6012/54 S	Optional extension of lift-off protection (M16) for PR 6012/41 and PR 6012/42	940536012542
PR 6012/63 S	Pivot for PR 6212/500 kg – 10 t	940536012632

The technical data given are intended solely as a product description and should not be conceived as guaranteed properties in the legal sense.

Specifications subject to change without notice.

Rev. 08/2020

Minebea Intec GmbH  
 Meiendorfer Strasse 205 A  
 22145 Hamburg, Germany  
 Phone +49.40.67960.303  
 sales.hh@minebea-intec.com  
 www.minebea-intec.com