

# HIGHLY EFFICIENT SOFT MOUNTED WASHER EXTRACTORS WITH XCONTROL FLEX PLUS



**FX RANGE**

FX350 TOUCH	FX450 TOUCH	FX600 TOUCH
35KG 77LB	45KG 99LB	60KG 132LB



## FEATURES

- Freestanding, high spin
- Patented Cascade Drum™
- Stainless steel drum and tub
- 2x large drain valves (Ø 76 mm)
- Easy Soap™ - liquid soaps connection
- Large door opening for easy loading/unloading
- Ergonomic height of door enables easy access with trolleys
- RS485 plug (on the back panel)
- User Friendly control position regardless of the user's height
- Bumper (front side protection)
- Soap hopper

## XCONTROL FLEX PLUS PLATFORM

- 7" Touch intuitive programmer
- Available in 34 languages
- Factory built wifi for programming and updating
- Service alerts for easy maintenance
- Fully programmable
- 20 preset programs, up to 99 in memory
- Combine with Trace-Tech™ and i-Trace laundry management softwares for a perfect control of your laundry installation.

## OPTIONS

- Stainless steel front
- Liquid soap pumps
- Recycle valve
- 3rd water inlet, high inlets capacity
- Steam or Dual heat versions
- Air operated water inlets
- OPTILOAD™ - weighing system\*
- Water sample tap
- Extra signaling (orange light & horn)
- Insulation for energy and noise reduction
- Forward tilting (n/a for FX350)\*
- Extension up to 16 liquid soap signals (accessory)



XControl FLEX PLUS approach, program, and cycle screens

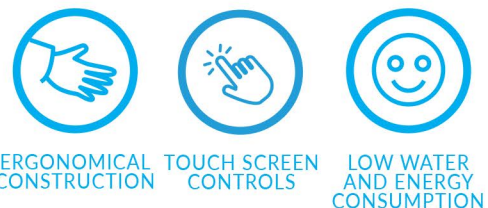

\*Consult your sales representative for availability

**GET AHEAD IN LAUNDRY**

TYPE		FX350	FX450	FX600
<b>INNER DRUM</b>				
Capacity 1:10	kg	35	45	60
Capacity 1:09	kg	39	50	67
Volume	litres	351	452	601
Diameter	mm	914	914	1035
<b>DRUM SPEED</b>				
Wash speed (max)	rpm	38	38	36
Extraction speed (max)	rpm	839	839	788
<b>G-FACTOR</b>				
		360	360	360
<b>HEATING</b>				
Electricity	kW	24	36	54
Steam	bar	3-8	3-8	3-8
Hot water	°C	90	90	90
Sound pressure level	dB (A)	<75	<75	<75
Water valves connection	BSP	1"	1"	1"
Water pressure	kPa	100-800	100-800	100-800
Rec. water pressure	kPa	300-500	300-500	300-500
Water inlet capacity (at 8 bar)	l/min	518	518	518
Drain valve	outer Ø			
	mm	2x76	2x76	2x76
Flow amount with drain valve	l/min	2x 210	2x 210	2x 210
Steam valve connection	BSP	3/4"	3/4"	3/4"
Steam pressure	kPa	300-800	300-800	300-800
<b>DIMENSIONS</b>				
Size H×W×D	mm	1925x1315x1270	1925x1315x1502	1925x1315x1502
Net weight	kg	1010	1350	1500
<b>TRANSPORT DATA</b>				
Packed H×W×D	mm	2125x1425x1470	2125x1425x1700	2125x1425x1700

Front side

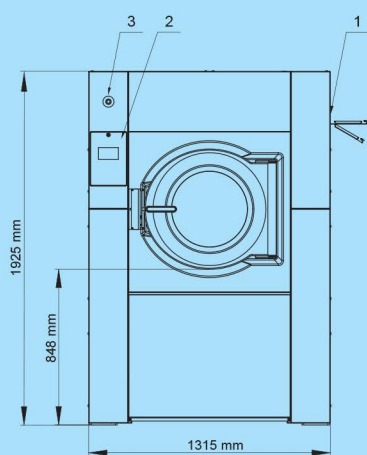

Left side

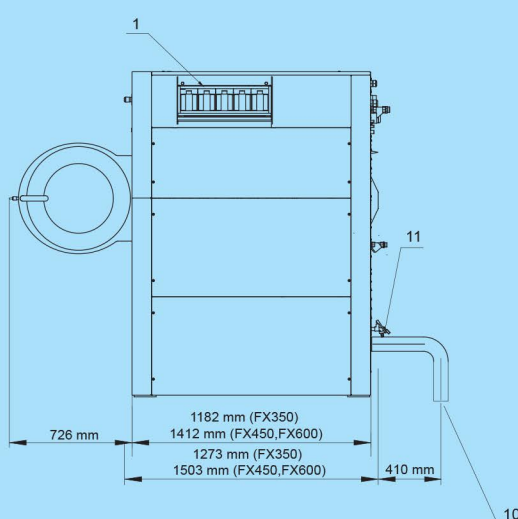

Rear side

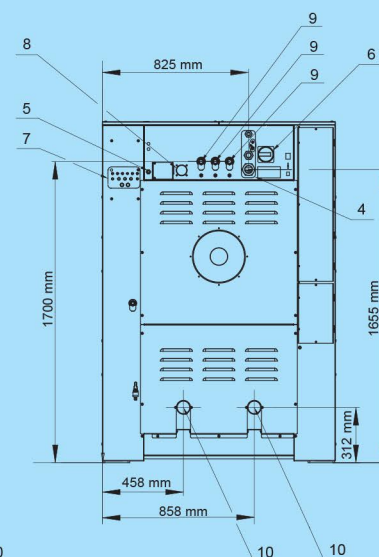

- 1 Soap hopper
- 2 Keyboard
- 3 Emergency stop
- 4 Electrical connection

- 5 Electrical connection to liquid soap
- 6 Main switch
- 7 Liquid soap pump connections

- 8 Air vent tub
- 9 Water connection
- 10 Drain valve
- 11 Water Sample Tap