

MADISON IM17

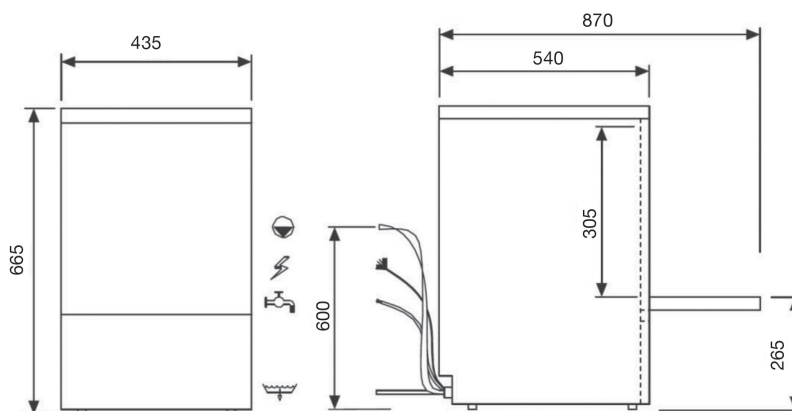

With European technologies specified to Norris' high standards for Australian conditions and demands, the IM17 commercial glasswasher will significantly lower your running cost. The electronic control system is based on the 'one button, one function operation' – simple and efficient. The technology in the IM17 glasswasher leaves other imported machines behind with better performance and considerable energy savings.

FEATURES

- **Warranty:** 2 years parts and labour, 3 years on the control board & cabinet

Ask about a 4-year extended warranty

- 60, 120 second wash cycle options
- Recycle wash system, using 2L per cycle
- Pump out drain
- Up to 800 glasses per hour*
- Automatic detergent injection
- Automatic rinse aid injection
- Automatic drain (no stem pipe)
- Double skinned door
- Easy clean pressed wash chamber
- Minimum rinse temperature cut out
- 15 amps
- High wash chamber

INCLUSIONS

- 1 x Wire glass rack insert 17"x14"
- 1 x Drain hose
- 1 x Water connection hose
- 1 x Operating manual

TECHNICAL DATA

Height	
Cabinet	665 mm
Cabinet inc. legs	807 - 867 mm
Usable Wash	305 mm
Width	
Cabinet	435 mm
Depth	
Cabinet	540 mm
With door open	870 mm
Capacities	
Loads/Hour	up to 30*
Water per Cycle	2L*
Wash Pump	300W
Wash Tank Litres	11
Boiler Tank Litres	2.6
Element (wash)	600W
Element (boiler)	2600W
Detergent Injection	yes
Rinse Aid Injection	yes
Temperatures	
Wash Degrees C	60 °C
Rinse Degrees C	82 °C
Plumbing	
Drain	Pump out
Water	¾" BSP (hot)
Electrical	
Volts/Hz	240V AC/50Hz
Amps	15amps

* Subject to incoming water temperature + pressure

Water pressure requirements are: 10L/min at 200-400 kPa max.

