

ReFlex Series, 3 Door (Solid), Medium Pizza Preparation Fridge

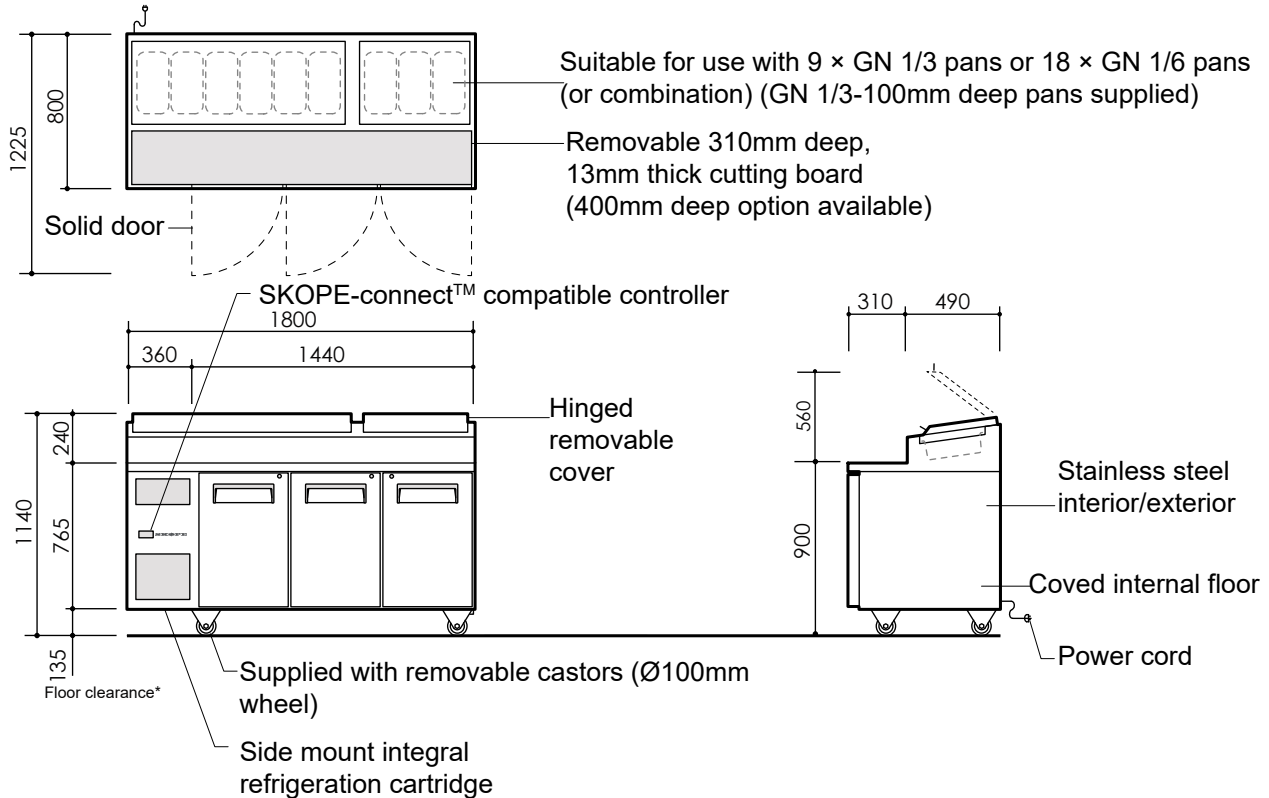

CABINET

Doors	3 x self-closing, lockable, solid swing door with stay-open position at over 90°, hinged LH, LH, RH.
Internal door opening	3 x door openings: 590mm high x 370mm wide
Shelves	6 x adjustable height shelves: Middle shelves: 475mm wide x 610mm deep. Outside shelves: 415mm wide x 610mm deep. Each shelf is held in place with four shelf clips, and additional shelf clips available on request.
Worktop	Removable, food grade, 13mm plastic cutting board
Material	304 AISI stainless steel interior and exterior

PERFORMANCE

Max. ambient temp.	40°C
Temperature range	1°C to 5°C (adjustable with SKOPE-connect 0°C to 15°C)
Total energy consumption	5.45 kWh/24h (@ 30°C/55%RH)
Annual running cost	\$597 p.a. (@ \$0.30/kWh)

ELECTRICAL

Electrical safety climate class	5 (40°C/40% RH)
Interior lighting	2 x 400mm, 4W LED light (door activated)
Power cord	Supplied with 2.7m, 10 Amp plug and lead
Power supply	220-240 Volts a.c. 50 Hz, single phase supply
Current draw	3.5 Amps (includes unit 2.2 Amps)

REFRIGERATION

Controller	SCS Connect (SKOPE-connect compatible)
Connectivity interface	Bluetooth® wireless technology
Refrigeration system	Side mounted, integral, removable refrigeration cartridge (part number ULQCNI-0030)
Refrigerant	R290/90g (natural refrigerant)
Nominal capacity	900 Watts
Heat rejection (Avg/peak)	230 Watts/290 Watts
Drainage	No plumbing required

DIMENSIONS

	External	Internal
Height	1140mm	605mm
Width	1800mm	1350mm
Depth	800mm	640mm
Floor area	1.44m ²	
Weight	212kg	
Gross volume	523L	

Height variation

Supplied castors	1140mm
Supplied height adjustable legs	n.a.
No castors	1005mm

Dimensional tolerances

Before installing this cabinet allow the following dimensional tolerances:

Linear dimensions	Cabinet overall dimensions	
Less than 1 metre	±5mm	
More than 1 metre	-5mm to +10mm	
	Length of multiple cabinets	
	At each joint	At each end
Less than 1 metre	±5mm	+15mm
More than 1 metre	-5mm to +10mm	+15mm

Ventilation requirements

Top	Not required
Sides	Not required
Back	Not required
Bottom	Not required