

GT SERIES BATTERY TORQUE WRENCHES

SF **SPECIALISED FORCE**
HYDRAULIC TOOLS & ELECTRICAL CONTRACTORS EQUIPMENT
PTY. LTD.



GT SERIES BATTERY TORQUE WRENCHES

**GT200EBS GT500EBS GT800EBS
GT130EBS GT2600EBS**



MODULAR SYSTEMS

The GT series of battery operated torque wrenches was created to address several critical needs of the heavy bolting industry. Everyone enjoys the freedom that comes along with a powerful cordless torque wrench, but that usually means making compromises such as: handling a heavier tool, low number of cycles from a battery charge, low tool accuracy, unclear torque output, limited number of torque settings, dealing with a fragile tool that breaks easily and the list goes on. As our staff developed this TORQ Fusion® product line, they addressed all these inconveniences. When considering the weight of our tools as shown in the table on page 5, we build some of the lightest tools on the market when compared to the maximum torque each one produces. We also pride ourselves in leading the market in number of cycles per battery charge – we challenge you to try one of our tools along side any competitors’ to see for yourself. Our published torque accuracy is 5% of set torque and with our wrenches it is easy to see: the large screen on the back of the tool leaves no doubt as to what torque the tool was set at. The first time you hold one of these tools you will feel the quality that is built into every one, from the anodized aluminum motor housing to the solid polymer grip. Just like our other product lines, the battery series feature a modular design allowing the user to quickly change between available output drives, reaction arms, extensions and various custom accessories as needed, making it the most versatile torque delivery system on the market.

BATTERY TORQUE WRENCH

www.specialisedforce.com.au

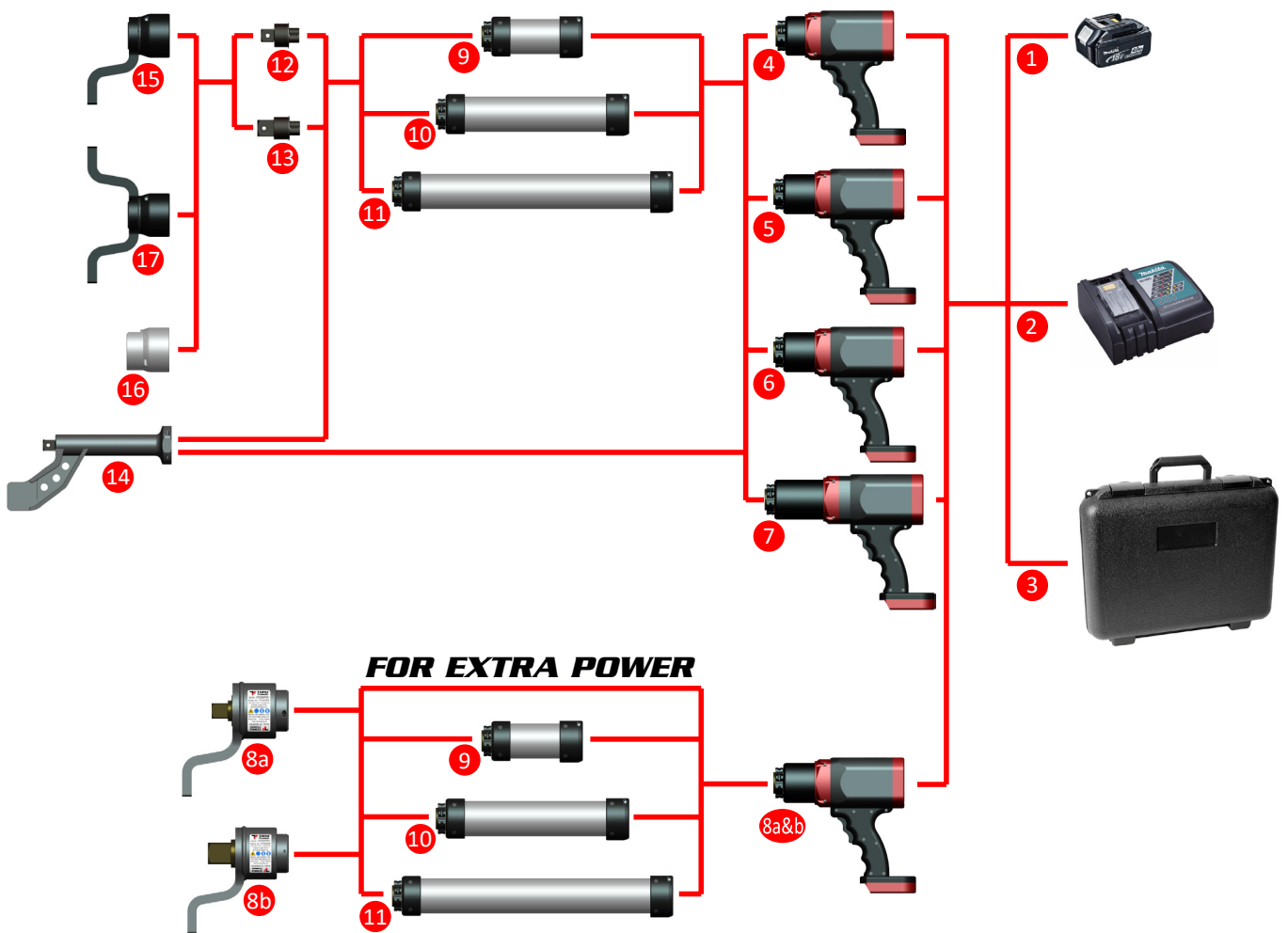

MODULAR SYSTEMS

| BATTERY TOOL - INDIVIDUAL COMPONENTS | | | | |
|--------------------------------------|--------------|---|-------------|--------------|
| ITEM | PART NUMBER | DESCRIPTION | WEIGHT (KG) | WEIGHT (LBS) |
| 1 | 001-P-0207 | 18V Li-Ion BATTERY, 5.0 Ah | 0.6 | 1.4 |
| 2 | 001-P-0208 | 18V BATTERY CHARGER | 0.7 | 1.6 |
| 3 | 001-P-0213 | CASE, BATTERY TOOL | 1.0 | 2.1 |
| 4 | 001-A-0119 6 | GT200EBS BATTERY TORQUE WRENCH, BARE TOOL | 3.6 | 8 |
| 5 | 001-A-0120 6 | GT500EBS BATTERY TORQUE WRENCH, BARE TOOL | 4.1 | 9 |
| 6 | 001-A-0121 6 | GT800EBS BATTERY TORQUE WRENCH, BARE TOOL | 4.1 | 9 |
| 7 | 001-A-0122 6 | GT1300EBS BATTERY TORQUE WRENCH, BARE TOOL | 5.1 | 11.2 |
| 8a | 001-A-0139 7 | GT2600EBS BATTERY TORQUE WRENCH, BARE TOOL, 1" SQ | 8.8 | 19.3 |
| 8b | 001-A-0123 7 | GT2600EBS BATTERY TORQUE WRENCH, BARE TOOL, 1-1/2" SQ | 8.8 | 19.3 |
| 9 | 001-A-0044 | 6" TOOL EXTENSION | 2.1 | 4.6 |
| 10 | 001-A-0043 | 12" TOOL EXTENSION | 3.1 | 6.9 |
| 11 | 001-A-0038 | 18" TOOL EXTENSION | 4.1 | 9.1 |
| 12 | 001-A-0053 | 3/4" STANDARD SQUARE DRIVE | 0.2 | 0.4 |
| 13 | 001-A-0054 | 1" STANDARD SQUARE DRIVE | 0.2 | 0.4 |
| 14 | 001-A-0078 | WHEEL BOLTING ATTACHMENT | 2.3 | 5.1 |
| 15 | 001-A-0072 | STANDARD REACTION ARM | 1.3 | 2.9 |
| 16 | 001-F-0205 | REACTION ARM WELD BLANK | 0.8 | 1.8 |
| 17 | TBA | CUSTOM REACTION ARM WELD BLANK | TBA | TBA |

BATTERY TORQUE WRENCH
www.specialisedforce.com.au

FEATURES

Oversized brushless motor ensures maintenance-free operation, long life and low operating temperature

Drive receptacle and reaction mount compatible with all existing TORQ Fusion accessories

Forward / Reverse rocker trigger

Makita® compatible 18V Li-Ion battery



Clearly visible serial number label for easy tool identification

Durable aircraft aluminum motor housing

Solid polymer handle for operator comfort

GT200EBS | GT500EBS | GT800EBS | GT130EBS | GT2600EBS



5 yellow LEDs indicate percent of set torque achieved. All LEDs turn green when set torque is reached and red if the set torque is not achieved.

2 line display shows set torque when operating in torque mode and set torque and angle when operating in turn-of-the-nut mode.

Multi-function button allows set torque to be adjusted when pressed once, toggles between torque mode and turn-of-the-nut mode when held for 3 seconds and changes the units when held for 5 seconds.

Large buttons allow easy operation even when wearing work gloves. Pressing any buttons or the trigger powers on the tool. Tool automatically powers off after 10 minutes of inactivity.

Tool motor automatically stops after achieving the set torque within 5%, then turns backwards several degrees to enable easy removal of tool from reaction point and also provides visual indication that the work is complete.



GT2600EBS (MADE IN USA)



Two dedicated LEDs indicate whether the tool is working as an 800 ft-lb tool or a 2600 ft-lb tool at all times.

The tool automatically switches calibration parameters when its personality is changed. To use the GT2600PSS as an 800 ft-lb tool, the 2600 reducer must also be removed – this is accomplished in seconds by taking out 2 screws.

Changing the tool personality is done by pressing these 2 buttons together.

Multiple personality tools such as the GT2600PSS can also work as a GT800PSS tool – users get two completely different tools in one. They also have all the features of the other tools described above.



Removal of 2600 reducer requires the removal of two screws, then the reducer slides out.



This versatile tool allows torque ranges between 100 and 2600 ft-lbs. The conversion process takes under a minute.

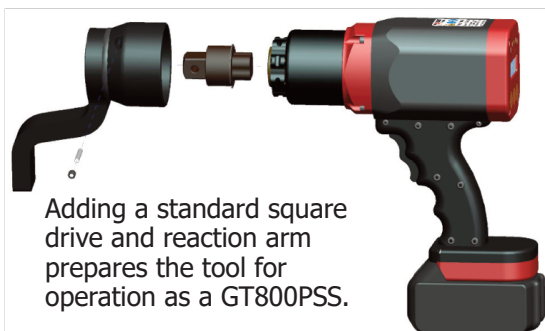

Adding a standard square drive and reaction arm prepares the tool for operation as a GT800PSS.

BATTERY TORQUE WRENCH

www.specialisedforce.com.au

BATTERY TORQUE WRENCHES

| PARAMETER | GT200EBS | | GT500EBS | | GT800EBS | | GT1300EBS | | GT2600EBS | |
|---------------------------|---|------------|---------------|------------|---------------|---|----------------|-------------|-----------------|-------------|
| | IMPERIAL | METRIC | IMPERIAL | METRIC | IMPERIAL | METRIC | IMPERIAL | METRIC | IMPERIAL | METRIC |
| Output Drive | 3/4" SQ | | 3/4" or 1" SQ | | 3/4" or 1" SQ | | 1" SQ | | 1" or 1-1/2" SQ | |
| Max Torque | 200 ft-lbs | 270 N-m | 500 ft-lbs | 680 N-m | 800 ft-lbs | 1080 N-m | 1300 ft-lbs | 1760 N-m | 2600 ft-lbs | 3530 N-m |
| Min Torque | 20 ft-lbs | 20 N-m | 60 ft-lbs | 80 N-m | 100 ft-lbs | 130 N-m | 160 ft-lbs | 210 N-m | 320 ft-lbs | 430 N-m |
| Max Speed | 46.6 | | 12.2 | | 8.6 | | 5.4 | | 2.4 | |
| Cycles per Charge | 240 fasteners tightened at max torque with no pause | | | | | 310 fasteners tightened at 80% of max torque with no pause ¹ | | | | |
| System Accuracy | 5% | | | | | | | | | |
| Tool Weight ² | 9.4 lbs | 4.3 Kg | 10.4 lbs | 4.7 Kg | 10.4 lbs | 4.7 Kg | 12.6 lbs | 5.7 Kg | 20.7 lbs | 9.4 Kg |
| Total Weight ³ | 12.7 lbs | 5.8 Kg | 13.7 lbs | 6.2 Kg | 13.7 lbs | 6.2 Kg | 15.9 lbs | 7.2 Kg | 20.7 lbs | 9.4 Kg |
| Battery | Makita compatible 18V Li-Ion 5.0 Ah standard | | | | | | | | | |
| Warranty | 1 year limited | | | | | | | | | |

1 - Higher number of cycles achieved with slight pauses between cycles

2 - Includes bare tool and battery – no reaction arm or square drive

3 - Includes bare tool, battery, standard reaction arm and square drive

GT200EBS DIMENSIONS (MM)

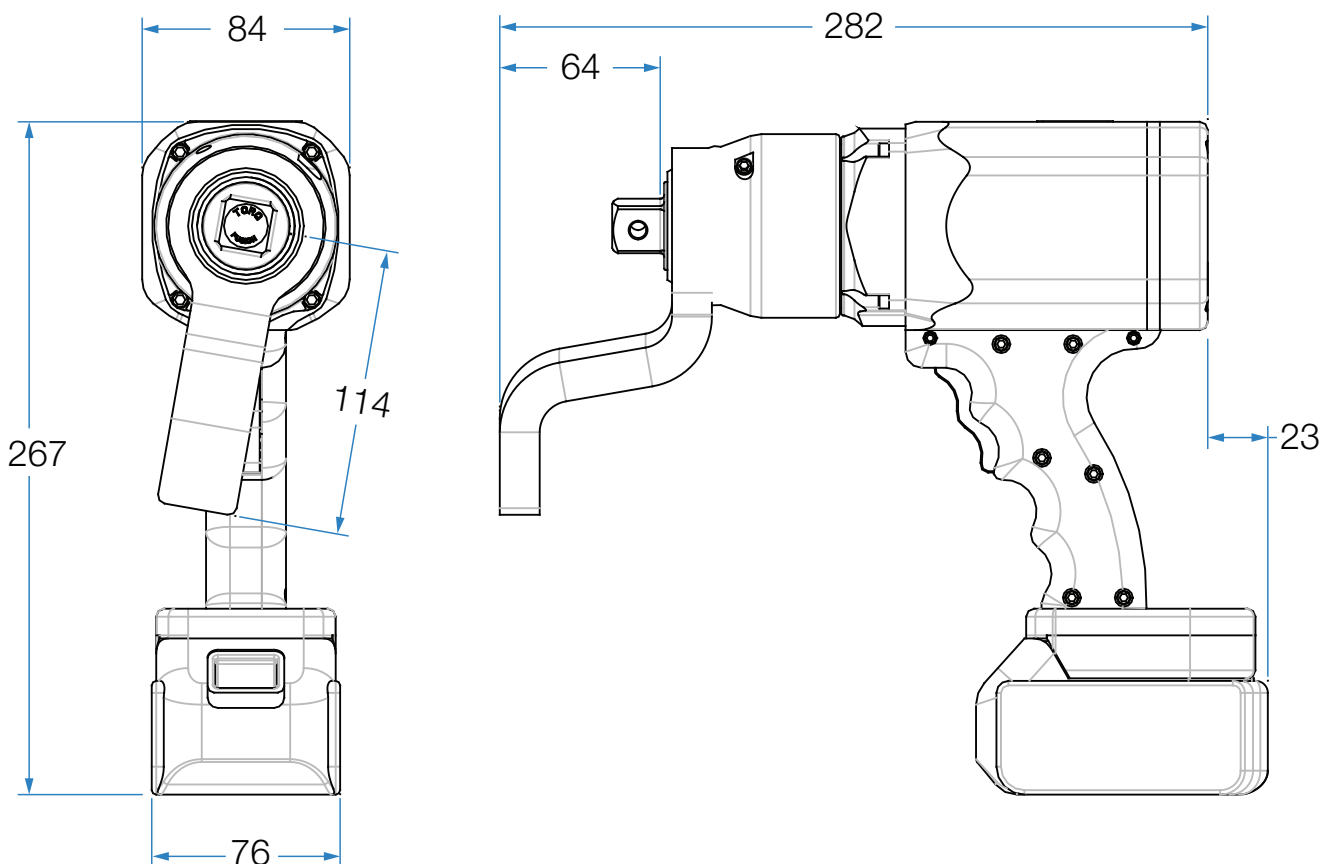



GT500EBS DIMENSIONS (MM)

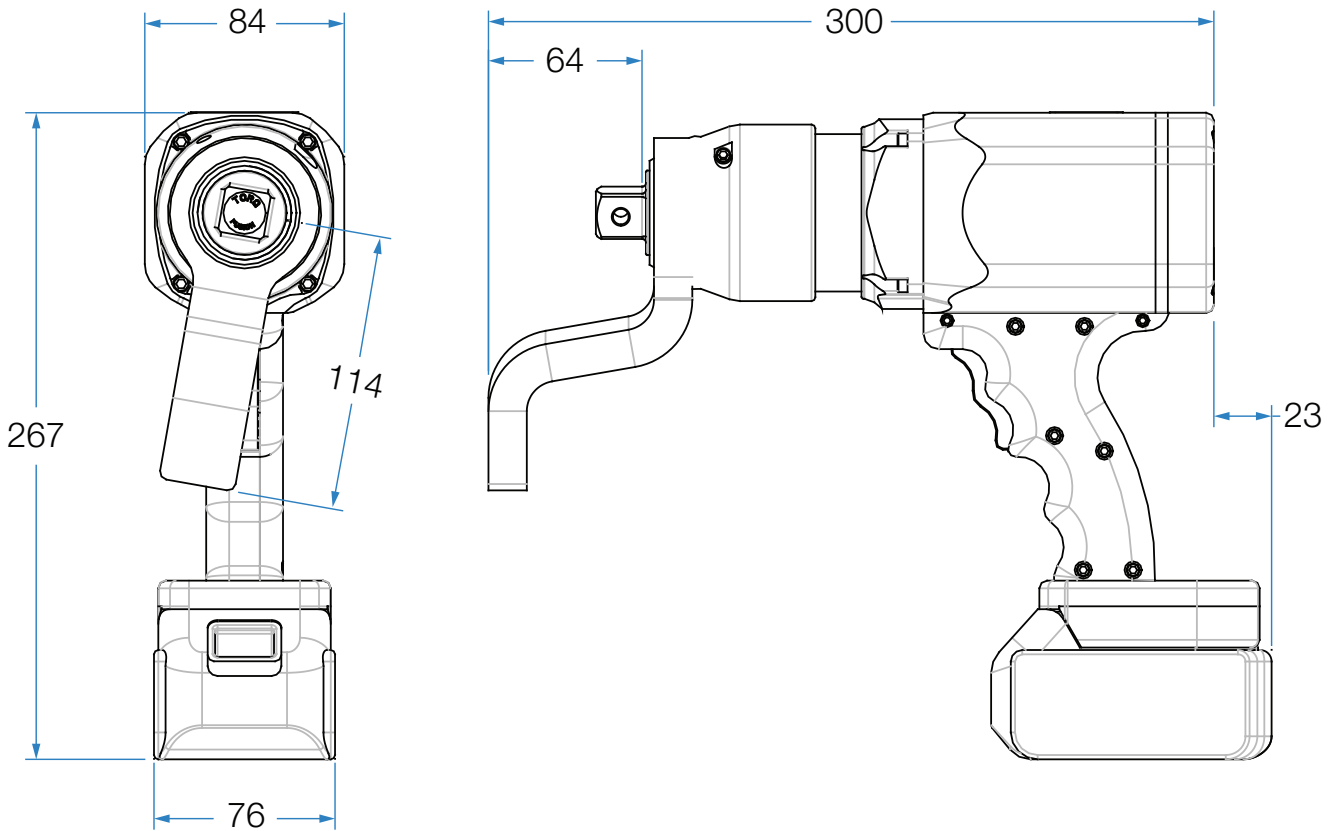

GT800EBS DIMENSIONS (MM)

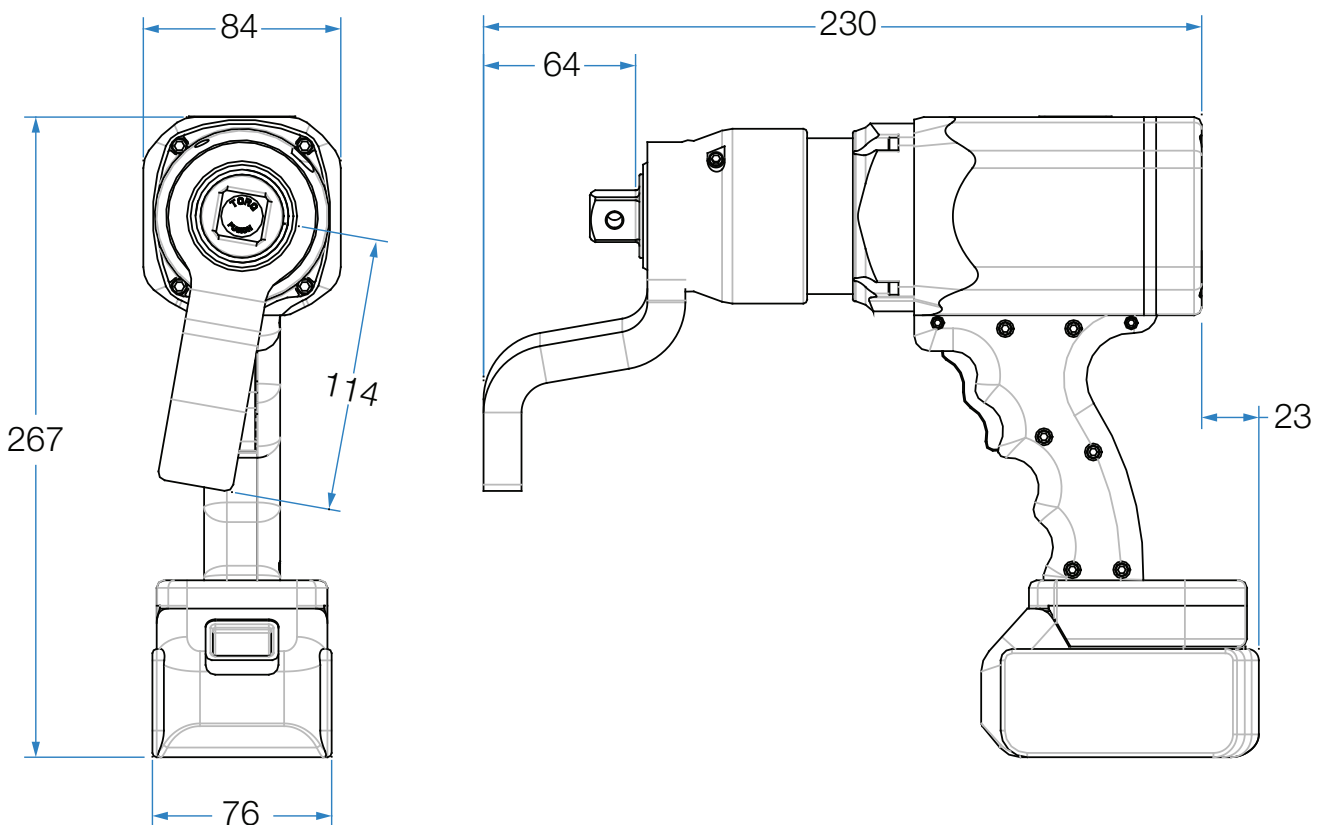

BATTERY TORQUE WRENCH

www.specialisedforce.com.au

GT1300EBS DIMENSIONS (MM)

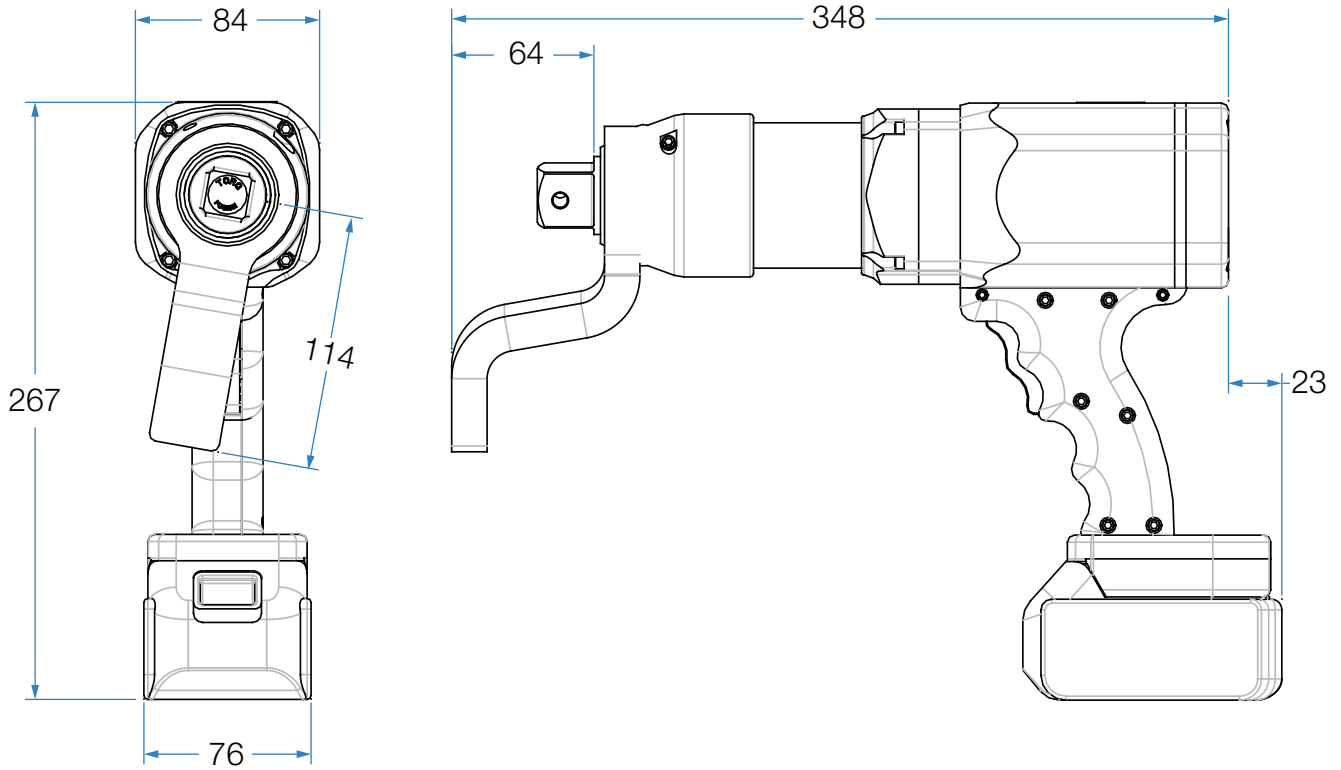

GT2600EBS DIMENSIONS (MM)

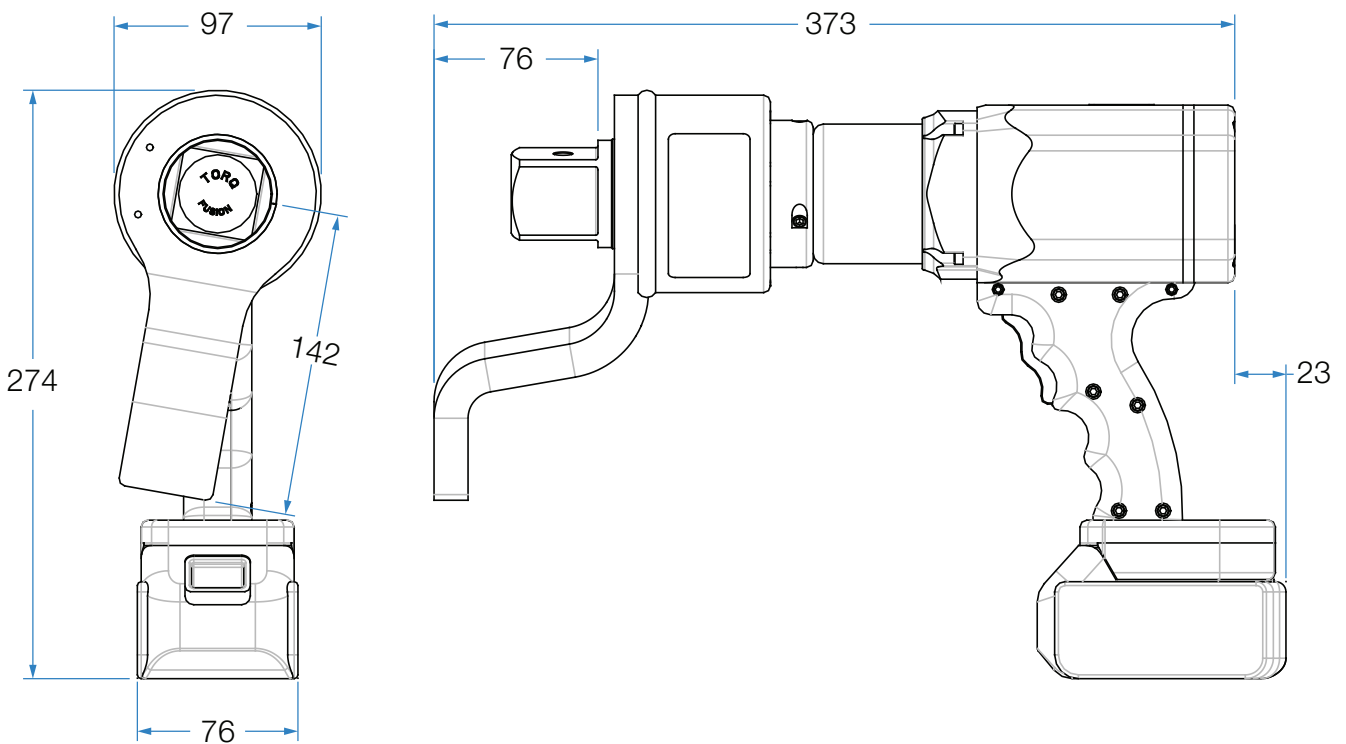

ACCESSORIES & POSSIBILITIES



GT800EBS with 12" extension, 3/4" square drive and standard reaction arm



GT1300EBS with 1" square drive and custom reaction arm

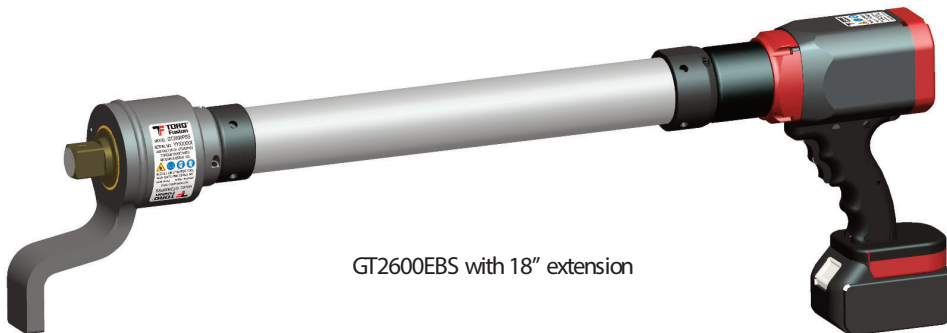

GT2600EBS with 18" extension



GT500EBS with wheel attachment



GT1300EBS with 6" extension and wheel attachment

BATTERY TORQUE WRENCH

www.specialisedforce.com.au