

# QLA 100i FOOD

## Quick-Lift Arm

**Intelligent lifting device with a hygienic design from ground and up. Incorporates the highest standards of ergonomics, safety, and efficiency.**

Especially suitable for washdown and damp environments, but also makes a perfect fit in dry areas.

Easy to use thanks to intuitive control handle, minimal operator force needed for any load weight.

Exceptional safety achieved using our intelligent control systems.

Uses pneumatic clamping for the most versatile design of end effectors.

High reliability and low power consumption results in superior cost efficiency.

# Quick-Lift Arm

# QLA 100i FOOD

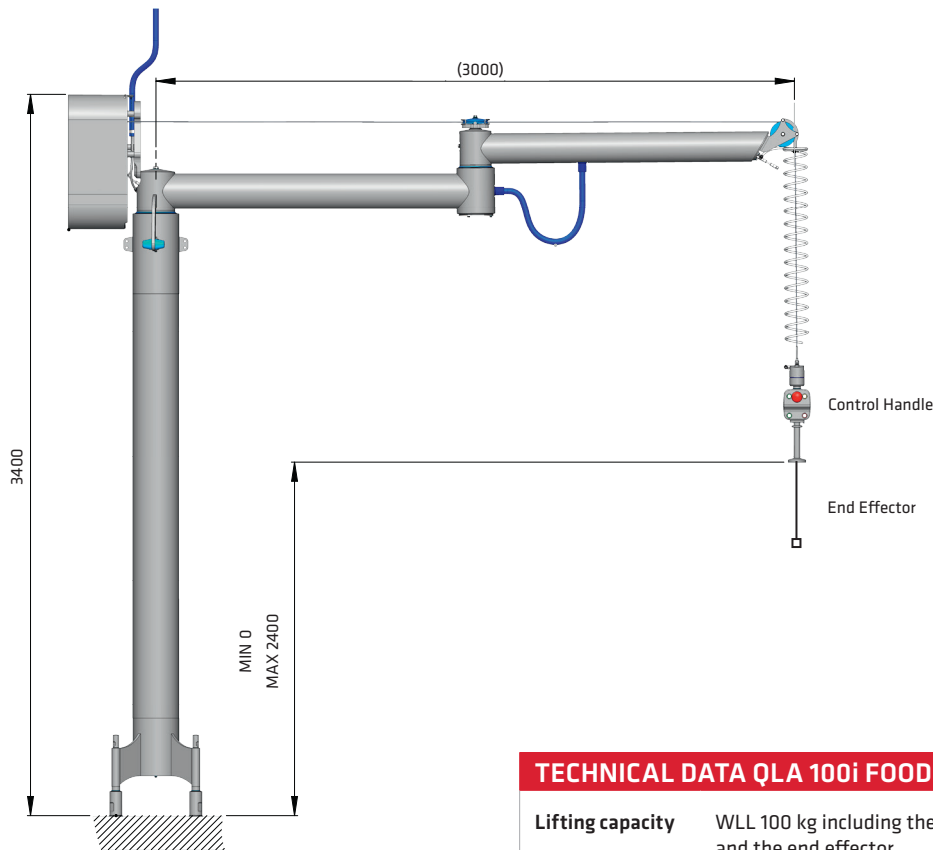

Recommended working area QLA 100i FOOD

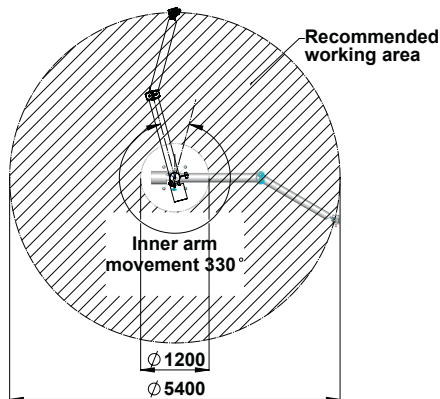

## Options

- Control handle for pneumatical clamping OR control handle for mechanical clamping.
- Higher surface finish on pillar and arms, Ra 1.6 instead of standard Ra 3.2.  
**Note:** Control handle surface finish is always higher (Ra 1.6).  
Extra grinding process on the welds.  
**Note:** All welds are free from cracks and polished to chosen Ra value.
- Stainless steel cover for motor unit to minimize time for daily cleaning.
- Good grade stainless steel fasteners.  
**Note:** Standard fasteners are stainless steel A4 quality, all external hex head for easier cleaning.

## TECHNICAL DATA QLA 100i FOOD

<b>Lifting capacity</b>	WLL 100 kg including the weight of the control handle and the end effector.
<b>Working area</b>	Max recommended working radius = 2.7 m from pillar.
<b>Stroke length</b>	2.7 meter
<b>Lift motor</b>	Highly efficient servo-controlled motor. Corrosion protected.
<b>Power supply</b>	230V, 50-60 Hz 1-phase with protective ground, 10A fuse
<b>Power consump.</b>	Typical average 100 W over a work cycle.
<b>Arm &amp; Pillar</b>	Round polished stainless steel tube design with no horizontal areas for water run-off and easy cleaning/sanitizing.
<b>Cleaning &amp; Sanitizing</b>	Withstands most common cleaning and sanitizing agents. Can be hosed down. NO high pressure washing.
<b>Environment</b>	Withstands continuous 100% humidity (RH). IP56 design and heated electronics.
<b>Temperature range</b>	0° to +40° C On request -20° to +10° C
<b>Attachment</b>	Raised pillar lower end for easy cleaning. Adjustable feet for slanting floor. Optional shorter or longer pillars.
<b>Manoeuvring</b>	Manoeuvring is done with Binar Handling's patented control handle. Only a small force is needed to engage the up/down motion. When the operator let go of the handle, the up/down motion is immediately stopped.
<b>End effector</b>	End effectors are designed to fit customers need. External sensor signals can be used for optimum functionality and safety.

Binar Handling AB disclaims responsibility for any errors or incomplete information in the published material and reserves the right to make changes.

## Binar Handling AB

Hedekullevägen 24 • SE-461 38 TROLLHÄTTAN • Sweden  
phone: +46 (0)520 47 40 00 • e-mail: info.handling@binarhandling.com  
www.binarhandling.com

# BINAR HANDLING

Part of the  Group