

I-SERIES

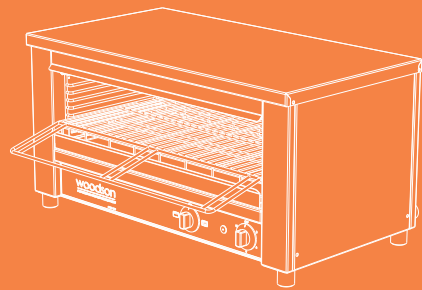

W.GTQI.15 toaster/grillers

APPLICATIONS

- Ideal for grilling or toasting foods in commercial cooking applications

CAPACITY GUIDE

- 15 slices - 575mm x 345mm rack
- Large 105mm height opening

FEATURES & BENEFITS

- Unique infrared glass elements with increased strength and durability providing long lasting reliability
- Incredibly even heat distribution for consistent cooking results
- Infrared elements provide immediate heat, with no need to leave the appliance running all day wasting energy
- Top and bottom elements with energy saving option of top element operation only
- New, multiple position slides and rack for easier and safer loading and unloading
- Extremely reliable - no troublesome fans or electronics
- Timer controlled operation only, guarantees power saving
- Stainless steel construction with new brushed finish
- Easily cleaned removable crumb tray



The instant heat of the infra-red elements



Now with more control of the cooking process

W.GTQI.15

W.GTQI.15 SPECIFICATIONS

Amps	15	3.5kW
W	725	D 536
		H 375

Dealer:

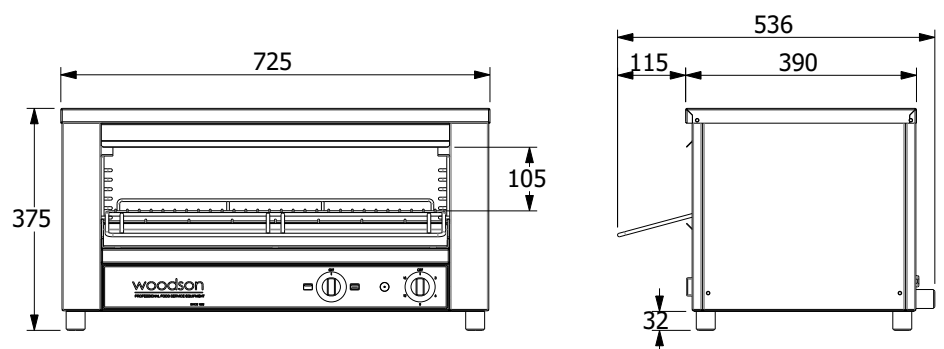

We reserve the right to alter specifications of products without notice

For details of your local dealer, contact:

QLD
Tel: 07 3440 7600
Fax: 07 3344 1000
fse@stoddart.com.au

NSW
Tel: 02 8832 4399
Fax: 02 8832 4355
sydney@stoddart.com.au

VIC & TAS
Tel: 03 9565 4699
Fax: 03 9565 4655
melbourne@stoddart.com.au

WA
Tel: 08 9414 1343
Fax: 08 9414 1361
perth@stoddart.com.au

SA & NT
Tel: 1300 79 1954
adelaide@stoddart.com.au