

HYWORTH
FORKLIFTS



Watch the
Lithium Electric Pallet
Jack in action



2T Lithium Electric Pallet Jack

H20PJ-Li

Load capacity
2.0 tonne

Collapsed height
200mm

Lift height
1160mm

Manoeuvrability

Ease of use





Light, compact and powerful, the 2T Lithium Electric Pallet Jack is the key to efficiently handling materials and pallets.



This electric-powered pallet jack provides a safer and more efficient alternative to the manual pallet jack.

Powered by lithium-ion technology, the battery requires no maintenance, is quick to charge and has longer running times. The 2T Lithium Electric Pallet Jack is perfect for busy and tight environments, including food and retail depots and warehouses. Ideal for use in warehouses, distribution centers and other industrial settings, the machine assists operators in moving heavy loads with efficiency.

Additionally, the 2T Lithium Electric Pallet Jack is useful for transport operations. With a weight of only 152kg, it won't bend the tailgate making it the perfect lightweight machine for truck tailgate unloading.

Versatile

Designed to handle pallets of various weights and sizes, its compact manoeuvrability and size make it ideal for an array of diverse warehouse applications.

Powerful

With a sizable 2.0-tonne capacity and lithium-ion battery, this machine provides ample power to lift heavy pallets.

Compact & durable

Its compact size makes it ideal for use in narrow aisles and tight spaces, while its durable construction ensures it can withstand the demands of warehouses.

Long-lasting

The lithium-ion battery lasts up to 6 hours and only takes one hour to charge, so operators can work longer without needing to stop and recharge.

Manoeuvrable

With a compact size, design, light weight of only 152kg, and a small turning radius, it is ideal for navigating tight spaces and climbing inclines.

No forklift licence required

The Hyworth Lithium Pallet Jack provides flexibility in terms of who can operate the machine, helpful for ad hoc tasks and more efficient resource allocation.

Safety & Ergonomics

Powerful traction motor - Reduce operator fatigue and increase productivity with a powerful traction motor for heavy lifting.

Emergency reverse button - Prevents the operator from being crushed in tight environments by enabling quick reversing in an emergency.

Upright vertical control - Control the machine easily with the ability to override the brake switch and manoeuvre through very tight areas.

Easy steering - Seamlessly move around the warehouse with effortless and comfortable steering while concentrating on tasks such as loading and lifting.

Auto park brake - Ensures the vehicle is safely parked at a complete stop once the accelerator has been released.

Excellent manoeuvrability - Reduce downtime and operator fatigue with the ability to handle most inclines or slopes, accelerate and decelerate quickly.

Efficiency & Productivity

Long battery life - Avoid downtime with an efficient lithium-ion battery, which lasts 5-6 hours without recharging or replacing.

Quick charge - Lithium-ion batteries have a higher energy density than other types of batteries. With a small, lighter battery, this machine only takes one hour to charge to 90% capacity.

Portable Battery - Operate in multiple locations without a dedicated charging station with the option for a portable 2nd battery to eliminate any down time.

Quick battery swap - Seamlessly remove and replace the battery in 10 seconds with easy access, causing no downtime to your operations.

Less downtime - Low maintenance means less downtime, keeping your machine moving and productivity high throughout the workday.

Regenerative braking - Reduce energy costs over time and the risk of accidents caused by excessive speed and sudden stops.

Serviceability & Reliability

Low maintenance - Reduced maintenance costs and increase productivity with fewer moving parts and less wear and tear than other pallet jacks.

Long battery life - Avoid disruptions and work more efficiently for more extended periods with a long-lasting battery.

High 2.0-tonne capacity lift - Decreasing time spent on each job with the ability to transport heavier loads and larger amounts of inventory simultaneously.

Light, compact and powerful - The pallet jack has the bonus of being in a light, compact design without compromising on power and durability.

Maintenance-free lithium battery - Unlike other battery types, adding water to the cells or equalising the charge of lithium-ion batteries is not required.

Reliability - The pallet jack is built with high-quality materials and has fewer moving parts than other pallet jacks, making it a reliable and cost-effective solution for many businesses.



Features

Safety

| | |
|---|----------|
| Auto park brake | Included |
| Anti-slide function on slope | Included |
| Emergency safety button | Included |
| Upright vertical control button | Included |
| Castor wheels | Optional |
| Anti-roll stabiliser bars | Optional |
| Load guard | Optional |
| Non-slip drive wheel | Optional |
| Rubber gutter ramp | Optional |
| Modularised moulded rubber container ramp | Optional |
| Digital keypad | Optional |



Efficiency

| | |
|---|----------|
| Custom speed settings | Included |
| Regenerative braking | Included |
| Plug & play removable lithium-ion battery | Included |
| Long battery life - up to 6-hour use | Included |
| Quick charge - 1 hour | Included |
| Document holder | Optional |
| Freezer proof specification | Optional |
| Rubber gutter ramp | Optional |



Ergonomics/comfort

| | |
|--|----------|
| Fingertip controls | Included |
| Compact | Included |
| Lightweight | Included |
| Easy steer tiller arm | Included |
| Hand-size 240v battery charger | Included |
| Additional quick-change 40 amp lithium-ion battery | Optional |





Technical Specifications

| | | | | |
|--|------|---|------------|----------------------------------|
| | 1.2 | Model Number | | H20PJ-Li |
| | 1.3 | Type of operation | | Pedestrian |
| | 1.4 | Rated Capacity / rated load | Q (kg) | 2000 |
| | 1.5 | Lift height | c (mm) | 200 |
| | 1.6 | Service weight with battery | (kg) | 152 |
| | 1.7 | Load centre | c (mm) | 600 |
| | 1.8 | Axle centre to fork face | x (mm) | 944 |
| | 1.9 | Wheelbase | y (mm) | 1243 |
| | 1.10 | Controller | | CURTIS |
| | | WHEELS | | |
| | 2.1 | Wheel type | | Polyurethane |
| | 2.2 | Driving wheel size | ø x w (mm) | ø 210 x 70 |
| | 2.3 | Loading wheel size | ø x w (mm) | ø 80 x 80 |
| | 2.4 | Wheels, number front / rear (x = driven) | | 1 x /2 |
| | 2.5 | Track width, rear, loading side | b11 (mm) | 400/535 |
| | | DIMENSIONS | | |
| | 3.1 | Overall length | l1 (mm) | 1600 |
| | 3.2 | Length to fork face | l2 (mm) | 453 |
| | 3.3 | Overall width | b1 (mm) | 550/685 |
| | 3.4 | Fork dimensions | s/e/l (mm) | 50/150/1150 |
| | 3.5 | Width of forks | b5 (mm) | 550/685 |
| | 3.6 | Lowered height | h13 (mm) | 85 |
| | 3.7 | Minimum ground clearance | m2 (mm) | 35 |
| | 3.8 | Height drawbar in driving position min / max | h14 (mm) | 740/1160 |
| | 3.9 | Aisle width with pallet 1000 x 1200 across forks | Ast (mm) | 1804 |
| | 3.10 | Aisle width with pallet 800 x 1200 along forks | Ast (mm) | 1854 |
| | 3.11 | Minimum turning radius | Wa (mm) | 1345 |
| | | PERFORMANCE | | |
| | 4.1 | Travel speed with / without load | (km/h) | 4.2/4.5 |
| | 4.2 | Max Gradeability laden / unladen | (%) | 6/10 |
| | 4.3 | Service brake type | | Electromagnetic |
| | | DRIVE AND BATTERY | | |
| | 5.1 | Drive motor, output s2 60 min | (kW) | 0.75 |
| | 5.2 | Lift motor rating at s3 15% | (kW) | 0.80 |
| | 5.3 | Battery according to din 43531 / 35 / 36 a,b,c no | (V/Ah) | no |
| | 5.4 | Battery voltage / rated capacity | | 48/20 (Lithium iron phosphate) |
| | 5.5 | Battery weight (+ 5%) | (kg) | 10.2 |
| | 5.6 | Charger specification | | 48v/10A (Lithium iron phosphate) |
| | | OTHERS | | |
| | 6.1 | Type of drive control | | DC |
| | 6.2 | Sound pressure level at drivers' ear | (dBB(A)) | < 70 |
| | 6.3 | Steering type | | Mechanical |

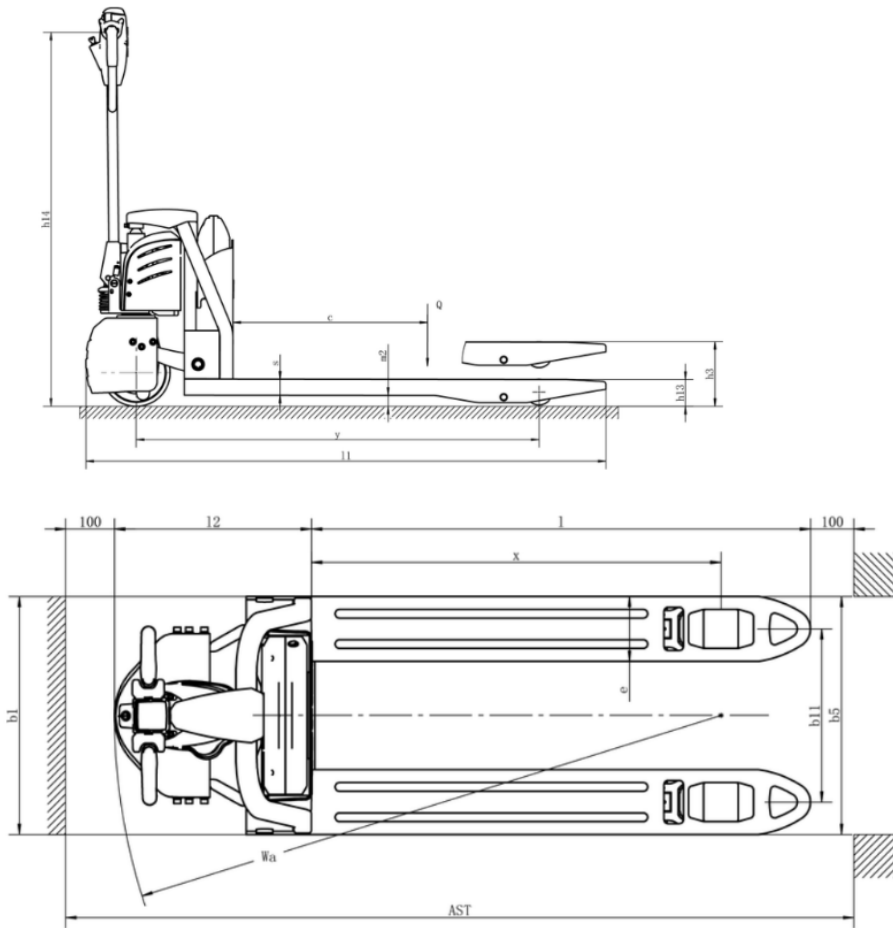

HYWORTH®

FORKLIFTS

Address: 2/12 Weld Street PRESTONS NSW 2170
 Phone: 1300 HYWORTH (1300 499 678)
 Email: info@hyworthforklifts.com.au
 Web: www.hyworthforklifts.com.au

