



FLEXICOMBI MAGICPILOT 6.1+10.1

ELECTRIC MKN No.: TKE061-101



Independent MKN combi steamer FlexiCombi stacked 6 tray and 10 tray GN 1/1 or FlexiRack® (530 x 570 mm) with MagicPilot operation system

Product Advantages:

- **MagicPilot** – Robust, wear-free, capacitive true colour touch screen.
- **Video assist** – Interactive user assistance with clips featuring professional chefs.
- **FlexiRack®** – 50% more cooking capacity (= save time and energy).
- **CombiDoctor** – Self-diagnosis programme.
- **AutoChef** – Up to 350 individual cooking programmes and manual operating system.
- Durable hygienic cooking chamber and chamber door with insulated **triple glazing**.
- **DynaSteam²** – Speeds up the cooking process and saves energy.
- Integrated heat exchanger.
- **WaveClean** – Automatic cleaning system (safe, easy, economical).
- USB interface.
- **3 years warranty parts and labour.**

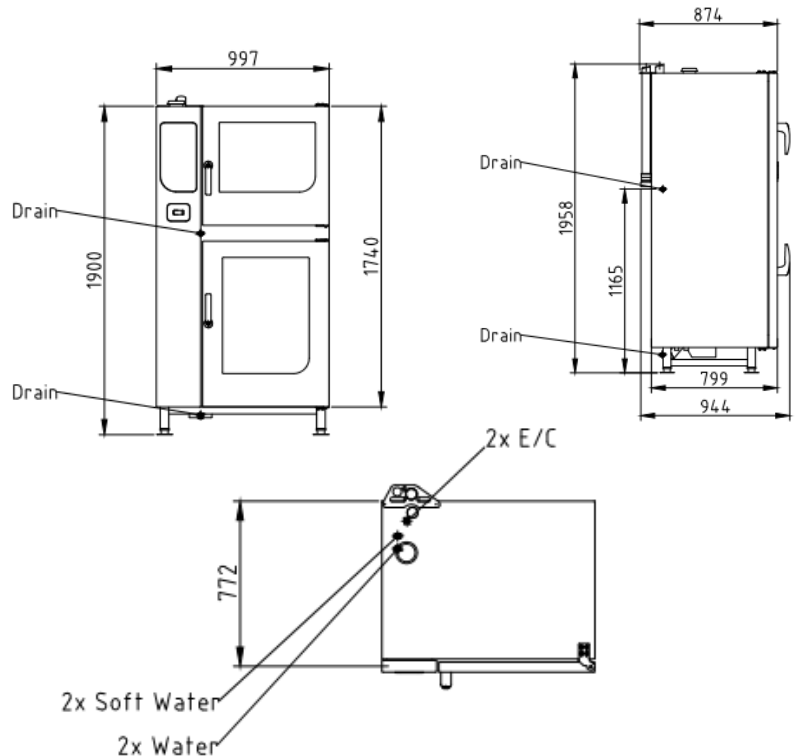

Installation requirements:

- Soft Water / Water supply / Connection to waste water provided by customer.
- If mineral content is high, reverse osmosis system may be advisable.

Technical Data:

Width x Height x Depth (mm)	997 x 1900 x 799
Connected load (electrical) (kW):	10.4 + 15.9
Voltage (V) / EC:	2x 415 3 phase AC
Recommended fuses (A):	3 x 20 + 3 x 32
Frequency range (Hz):	each 50
Soft Water connection:	2x DN 20 (R ¾" inside)
Water connection:	2x DN 20 (R ¾" inside)
Waterpressure (kPa):	each 200 -600 (2- 6 bar)
Drain connection:	each DN 50
Gastronorm 1/1 (530 x 325 mm):	6 + 10 (max. 65 mm deep)
FlexiRack® (530 x 570 mm)	6 + 10 (max. 65 mm deep)
Plates Ø 28 cm	24 + 40
Plates Ø 32 cm - plate trolley	22 + 40
Material housing:	1.4301
Material cooking chamber:	1.4404
Gross weight (kg):	340
Heat emission latent (W):	1780 and 2750 (4530)
Heat emission sensitive (W):	1190 and 1840 (3030)
Type of protection:	IPX 5

