

Technical data

GRANDES FLAMMES MILLENNIUM STANDARD or LUXE MODELS
REF: 1375-5ES or 1375-5ELN or 1375-5ELI ELECTRICAL

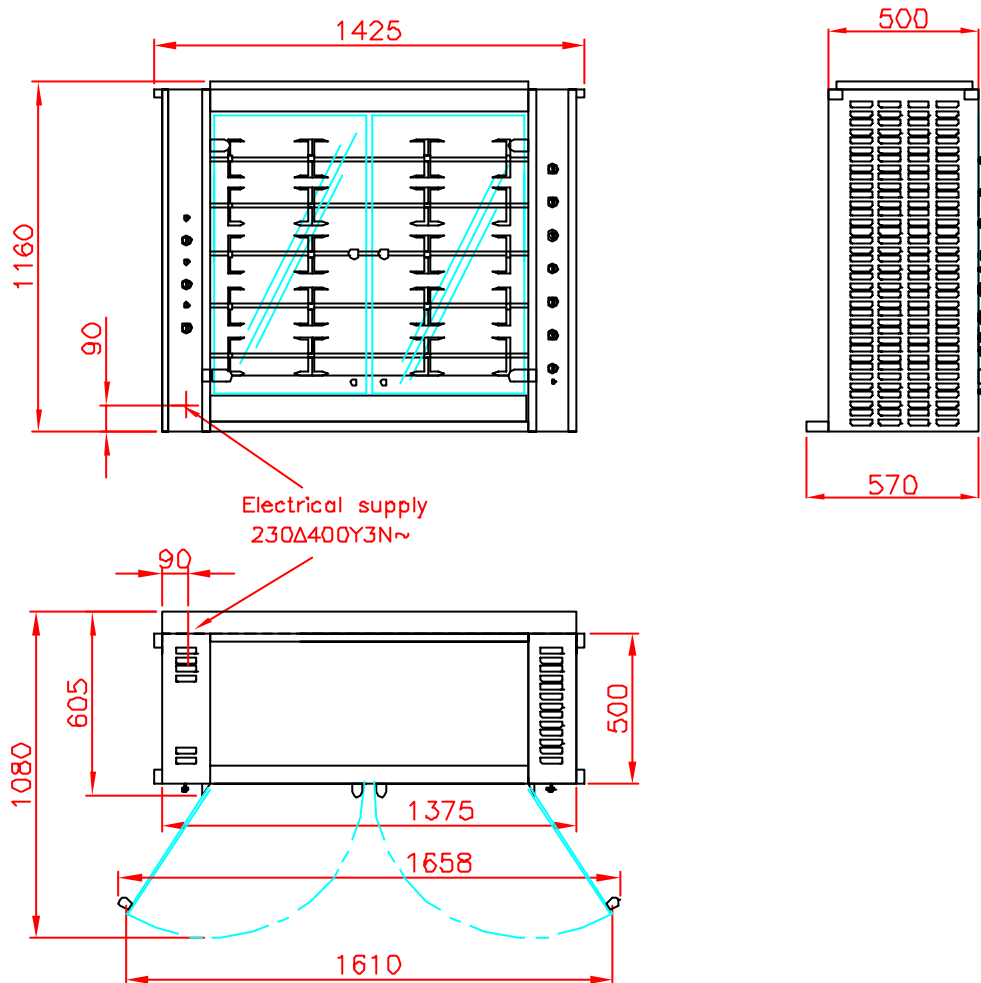

CHARACTERISTICS

Weight: 150 Kg, Weight packed without base cabinet: 210 Kg

Weight packed with base cabinet: 310 Kg

Capacity: 25/30 chickens, 5 ajustable spits

Black enamel and stainless steel for rôtissoirie réf: 1375-5ES (standard)

Black enamel and brass or stainless steel trim for rôtissoirie réf: 1375-5ELN (luxe)

Stainless steel and brass or stainless steel trim for rôtissoirie réf: 1375-5ELI (luxe)

Electrical supply 230V or 400V three phase+neutral+earth (230Δ400Y3N~), cable: 2 meters

Electrical power 20,6 kW, composed of:

_13 heating elements of 1,55 kW réf. RESI33, 5 motors of 30W réf. MOTGF75612C and
2 halogen lamps of 150W réf. LA78NM

OPTIONS: spécifique colours, base cabinet, heating base cabinet with doors or drawers,
protective roof.

OPTION, ACCESSOIRES: spits, vertical spit system, prongs, spit mover, grills, trays.