

# Aerated Grit Chamber WASTEMASTER DSF 2-3



# COMPACT PLANT FOR WASTE WATER TREATMENT

WASTEMASTER DSF consists of a sedimentation tank, a sand extracting screw and a floating screen. A grease scraper is available as an option for degreasing.

	Sedimentation	De-greasing
DSF 2	X	-
DSF 3	X	X

The first phase in the waste water treatment process is mechanical pre-treatment including:

- Sedimentation, lifting and de-watering of sand;
- Grease removal (DSF 3 only).

Subsequently the waste water is ready for further treatment (chemical, physical or biological), while solids are discharged for disposal.

## Overall Dimensions

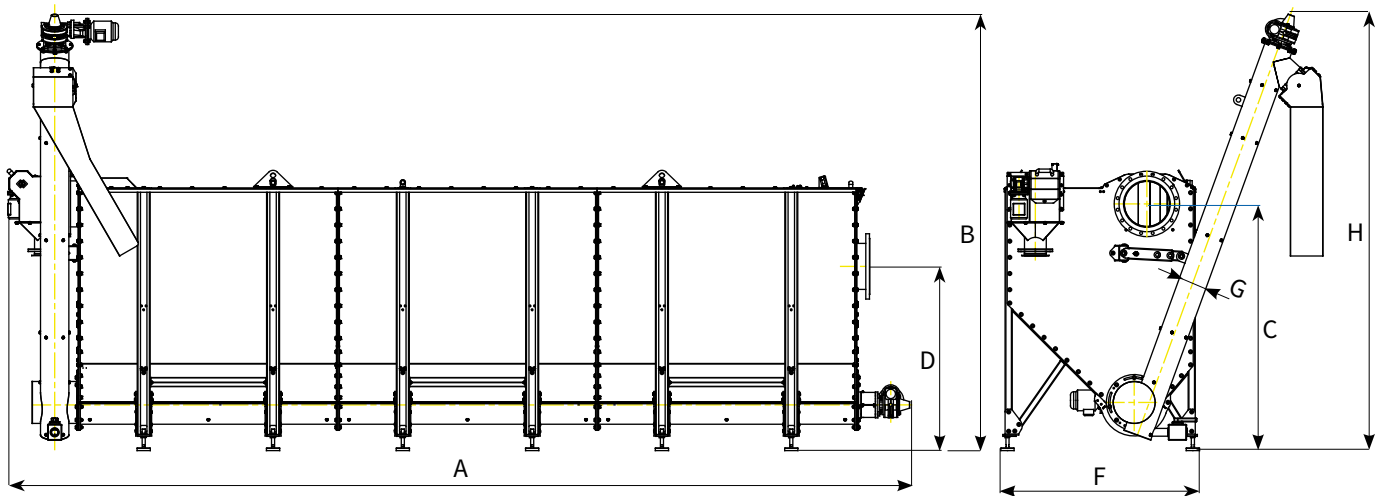

MODEL	A	A*	B	C	D	F	G	H
DSF S 10	2,850	3,735	3,300	1,680	1,330	1,100	168	2,925
DSF S 20	4,850	5,735	3,300	1,680	1,330	1,100	168	2,925
DSF M 10	4,830	5,785	4,075	1,900	1,425	1,420	219	3,375
DSF M 20	6,830	7,785	4,075	1,900	1,425	1,420	219	3,375
DSF M 30	8,830	9,785	4,075	1,900	1,425	1,420	219	3,375
DSF L 10	8,820	9,790	4,670	2,420	1,820	1,940	219	3,755
DSF L 20	10,820	11,790	4,670	2,420	1,820	1,940	219	3,755
DSF L 30	12,820	13,790	4,670	2,420	1,820	1,940	219	3,755

*Dimensions in mm*

## Benefits

- ✓ Decreased infrastructure costs
- ✓ Easy on-site machine assembly using standard tools
- ✓ Best footprint-net volume ratio for this type of machine
- ✓ Durable heavy-duty shaftless screws manufactured in patented process
- ✓ Self-adjusting scraper device
- ✓ SINT™ floating screw for heavy-duty applications (option)

## Features

- Flow rates of up to 210 litres per second (445 cfm)
- Sand separation with DSF2/ 3: 95% particle size  $\geq 200 \mu\text{m}$
- Grease removal with DSF3
- Modular design
- Self-adjusting scraper device
- Floating screw made of SINT™ engineering polymer ensures high removal of floating matter (option)

Option



Floating Screw System

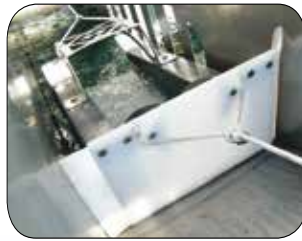

Self-adjusting grease scraper with limited water removal

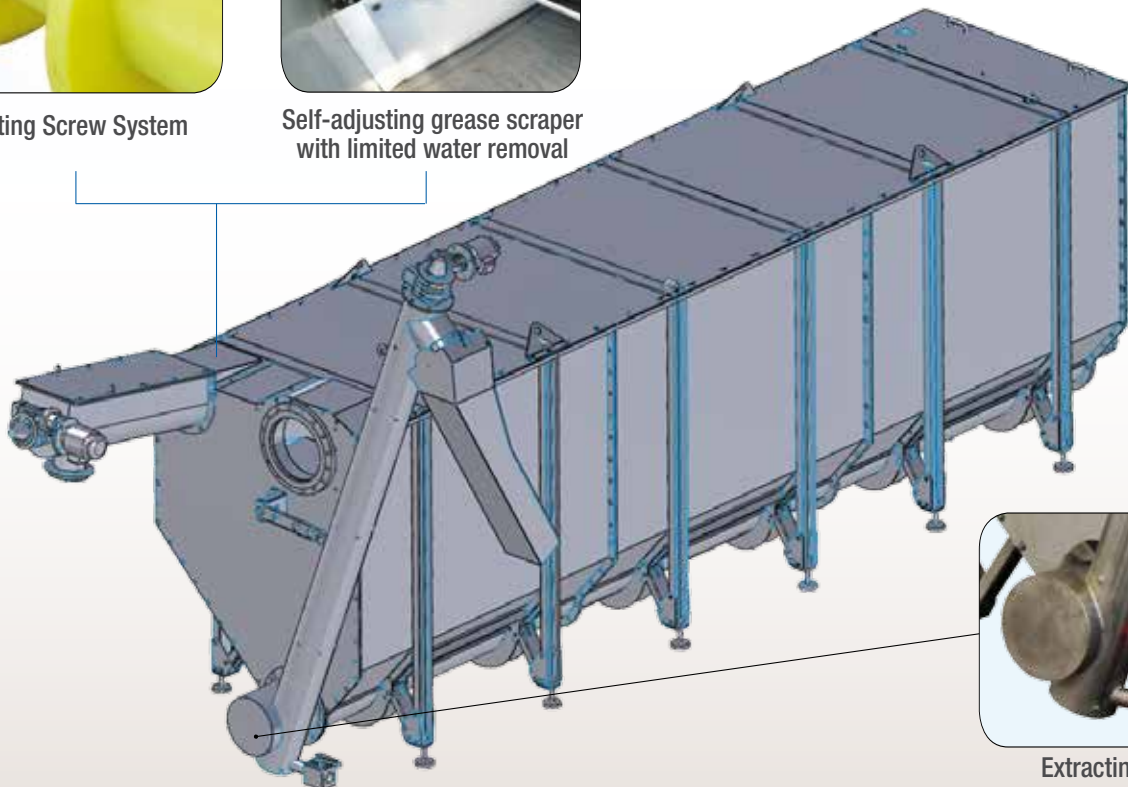

Extracting screw with variable inclination

## Accessories

- Blower
- Grease Pump
- Level Sensor
- Bagger

# Application



203001517 October 2018 Rights reserved to modify technical specifications.



This brochure has been edited for distribution in European Union countries



**SAVECO**<sup>™</sup>  
Member of WAMGROUP<sup>®</sup>



22 Beneficial Way Wangara WA 6065 ☎ (08) 6314 1100  
🌐 [inquip.com.au](http://inquip.com.au) ✉ [info@inquip.com.au](mailto:info@inquip.com.au)  
ABN 15 130 794 151

PRODUCT » DENSITY » FLOW