

PULSEO
GENERATION

HA20 LE / LE PRO



ECO-FRIENDLY

- > Electric drive and operations
- > Clean and silent operation designed for use in even the most sensitive work areas

VERSATILE. WORKS ANYWHERE, ANYTIME

- > Non-marking tyres for indoor use
- > 4 wheel drive for rough terrain use
- > Work quietly without work site disruptions

OPTIMAL PRODUCTIVITY

- > 360° continuous rotation turret (PRO model)
- > Quick, proportional and simultaneous movements
- > Large modular basket

EXTEND DUTY CYCLE, INCREASE PRODUCTIVITY

- > Power through a full work shift
- > Built-in multi-voltage charger
- > Low fuel consumption range extending engine



HA20 LE / LE PRO

ELECTRIC ROUGH TERRAIN ARTICULATING BOOMS

TECHNICAL DATA

	HA20 LE 4WD-2WS	HA20 LE PRO 4WD-4WS
Working height	20.3 m	20.4 m
Platform height	18.3 m	18.4 m
Horizontal outreach	11.9 m	
Up and over clearance	8.4 m	8.5 m
Lift capacity	250 kg (2 pers.) - option 350 kg	
F x G Platform size	1.83 x 0.80 m	
A Length	8.5 m	
B Width	2.4 m	
C Height - stowed	2.4 m	2.5 m
H Length - storage / transport	6 m	6.1 m
Storage / transport height	2.9 m	3 m
Platform rotation	180° (+ 90° / - 90°)	
Turntable rotation	355°	360° continuous
Tailswing	41 cm	
D Wheelbase	2.5 m	
E Ground clearance	37 cm	44.5 cm
Tilt	4 - option 6°	
Proportional drive speed	0.5 - 5 km/h	0.7 - 5 km/h
Maximum wind speed rating	45 km/h	
Gradeability	45 %	
Tyres - solid rough terrain	850 x 340 mm	1 025 x 365 mm
Turning radius - outside	4.5 m	3.8 m
Weight	9 375 kg	9 785 kg
Batteries	12 x 6 V - 435 Ah (C20)	
Range extender	Kubota, 18.5kW (Stage 5 in EU)	

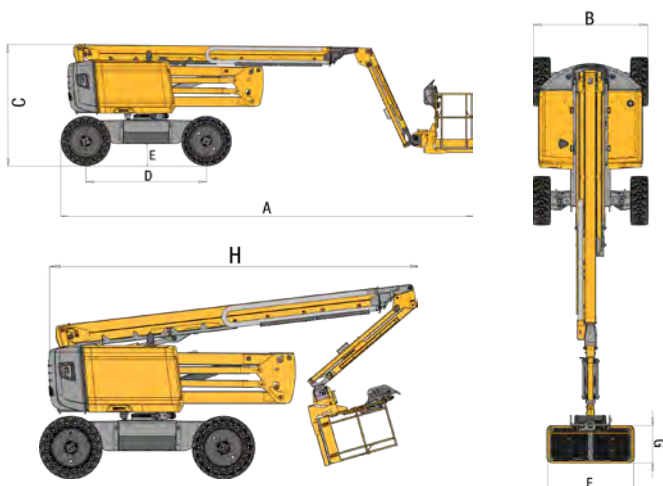

STANDARD EQUIPMENT

- > Haulotte Activ'Lighting System
- > Haulotte Activ'Shield Bar 2.0
- > Haulotte Activ'Screen
- > Universal telematics plug
- > Haulotte Activ'Energy Management: smart battery management system
- > Centralized battery watering system
- > 72 V battery pack (435 Ah)
- > Battery charge indicator at upper and lower control boxes
- > Multi-voltage charger (110 - 230 V) and integrated range extender (18.5 kW)
- > 4 wheel drive: brushless AC motors at each wheel
- > 4 wheel steer
- > Front oscillating axle
- > Smooth and proportional movements
- > Upper control box cover
- > Tool tray
- > Large modular platform 2.44 x 0.91 m with lateral swing door entry gate
- > AC power to platform (110 / 230 V) (option in AUS / NZ)
- > Swing out engine tray
- > Sound and light alarm for tilt and load
- > Travel alarm
- > Rotating beacon

OPTIONS AND ACCESSORIES

- > Haulotte Activ'Shield Bar 2.0 (standard in AUS / NZ)
- > Haulotte Dual Reach: additional load and tilt capacity up to 350 kg and 6° (optional)
- > Large platform 2.44 x 0.91 m (standard in AUS / NZ)
- > Side swing door entry gate (standard in AUS / NZ)
- > Pipe rack kit
- > Glazier kit
- > Power to platform 110 / 230 V (female plug in the basket)
- > Biodegradable hydraulic oil
- > Cold weather kit
- > Anti overspeed kit
- > Air-line to platform
- > Flashing light

