

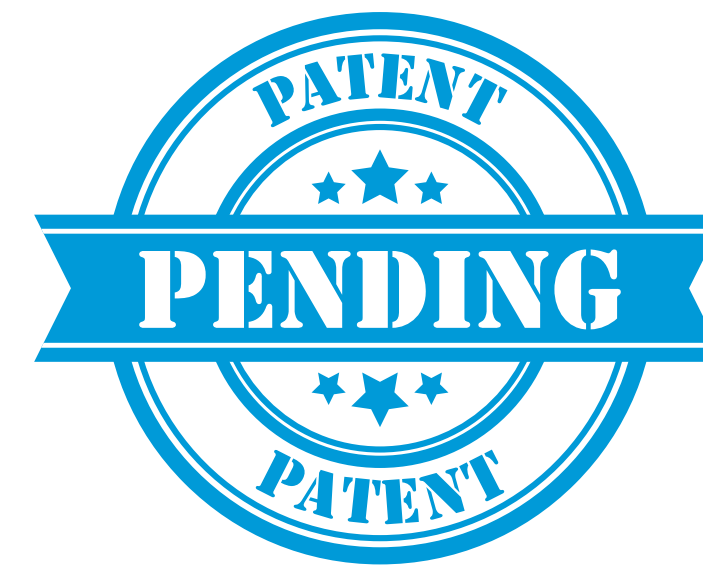

# AVURE® HPP

## FlexiBulk™

### FLEXIBLE BULK HPP PROCESSING

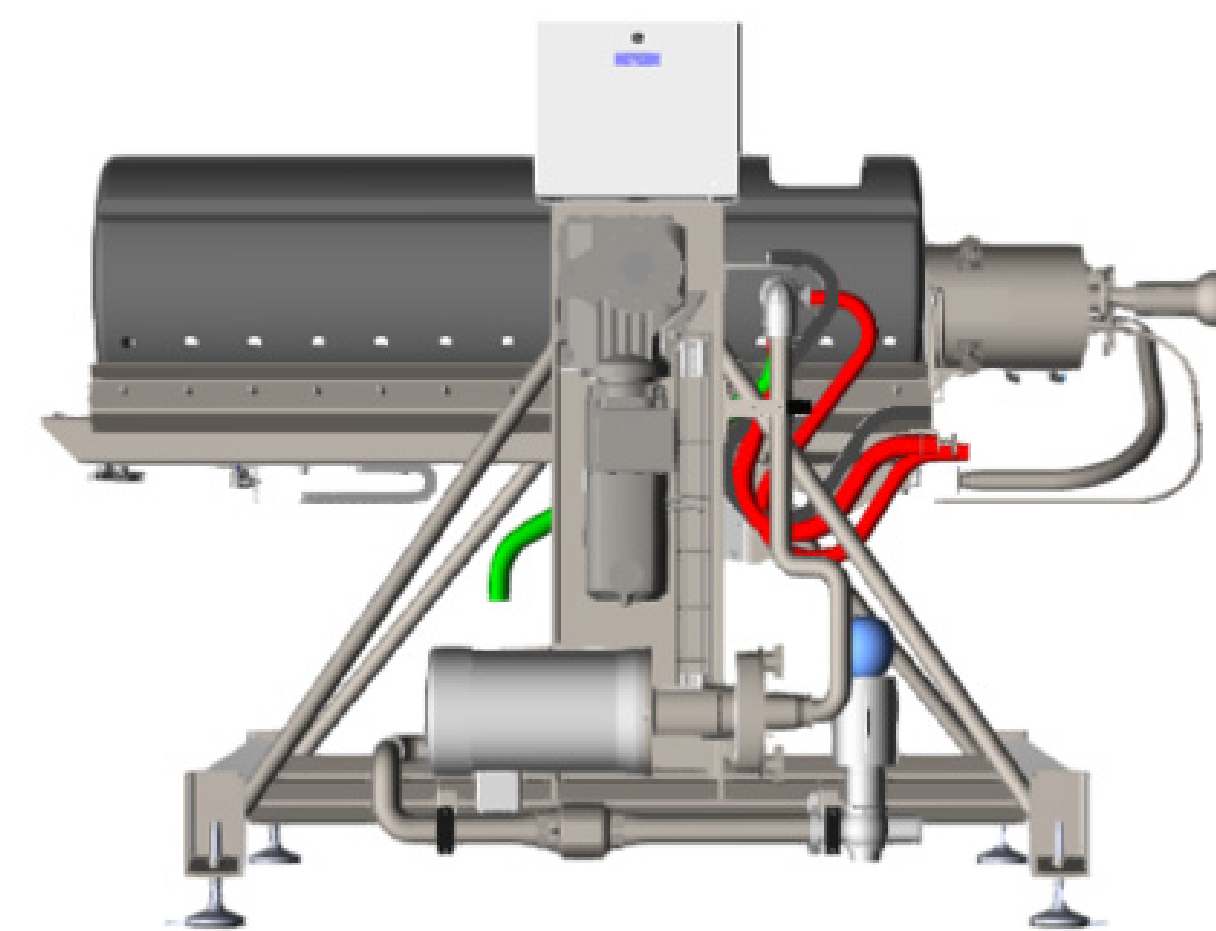

### PATENT PENDING FILL HEAD REDUCES LABOR USES COMMERCIALY AVAILABLE ASEPTIC BAGS

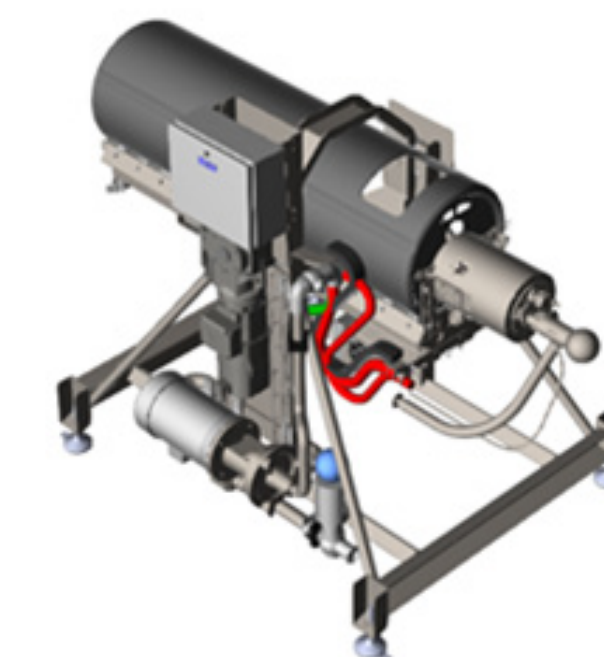
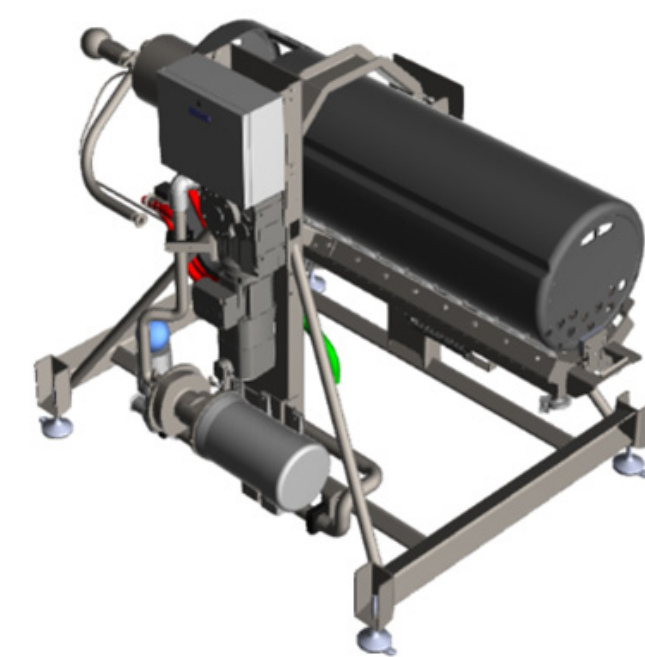

### CAPACITY

Increased packing density allows up to 80% increased throughput in the same machine



### FLEXIBILITY

- No machine modifications required
- Ability to run bulk and packaged products in the same cycle
- Different locations (or facilities) for filling and HPP processing

### SUSTAINABILITY

- Reduce plastic waste in the environment
- Multiple container options not normally available to HPP
- Reusable bags can be recycled



### SERVICE

- Patent pending process
- iOPS for troubleshooting and production reporting
- Remote support for troubleshooting
- Leverages JBT's long history of aseptic processing