



JOSPER CHARCOAL BROILER OVEN HJA

TECHNICAL INFORMATION

Recommended for ±	120 diners	
Fire up time	35 min average	
Charcoal daily consumption	12 to 16 kg	26.5 to 35 lb
Performance	9h	
Production per hour	90 kg average	192 lb average
Broiling temperature	250 to 350 °C	482 to 662 °F
Grill rack capacity in GN trays	2xGN1/1	
Tempering area capacity in GN trays	2xGN2/3 / 2xGN1/2	
Nominal heat output	7,4 kW	9.92 hp
Flue gas mass flow	15,39 g/s	0.54 oz/s
Smoke temperature	210 °C	410 °F
Net weight	430 kg	948 lb

HJA-45

The new Class A charcoal broiling oven is much more than a grill and an oven in a single machine. It is a unique equipment working 100% with charcoal, with a unique closed barbecue design, different levels of grilling, both flexible and robust, easy to use, with a front opening door, vent system for temperature control and double rack to gain productivity.

Class A efficiency improvements include hydraulic door retention, thermal insulation, new upper tempering area, greater accessibility, a more compact design and easy clean system. These upgrades result in an exponential increase in the quality and quantity of its production and the oven's final performance.

ACCESSORIES INCLUDED

Vent · Firebreak · Firebreak hat · 2 Grill racks · Tongs · Wire brush · Poker for coal · Ash pan · Wheels

INSTALLATION

Clearance with non-flammable equipment	100 mm	4 in
Clearance with flammable equipment	300 mm	12 in
Exhaust rate	3500 m3/h	2060 cfm

BUNDLES: SIZES AND WEIGHTS

Sizes bundle	850 x 1210 x 2000 mm	33 1/2 X 47 5/8 x 78 3/4 in
Gross weight bundle	505 kg	1113. lb

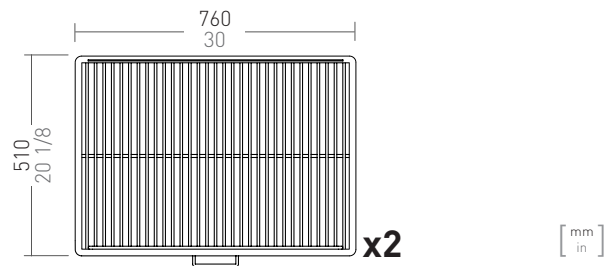

Ed.05.2019 - Josper reserves the right to make modifications to catalogues, pricelists and promotional material according to the development and improvements applied to its equipment.

JOSPER CHARCOAL OVEN HJA

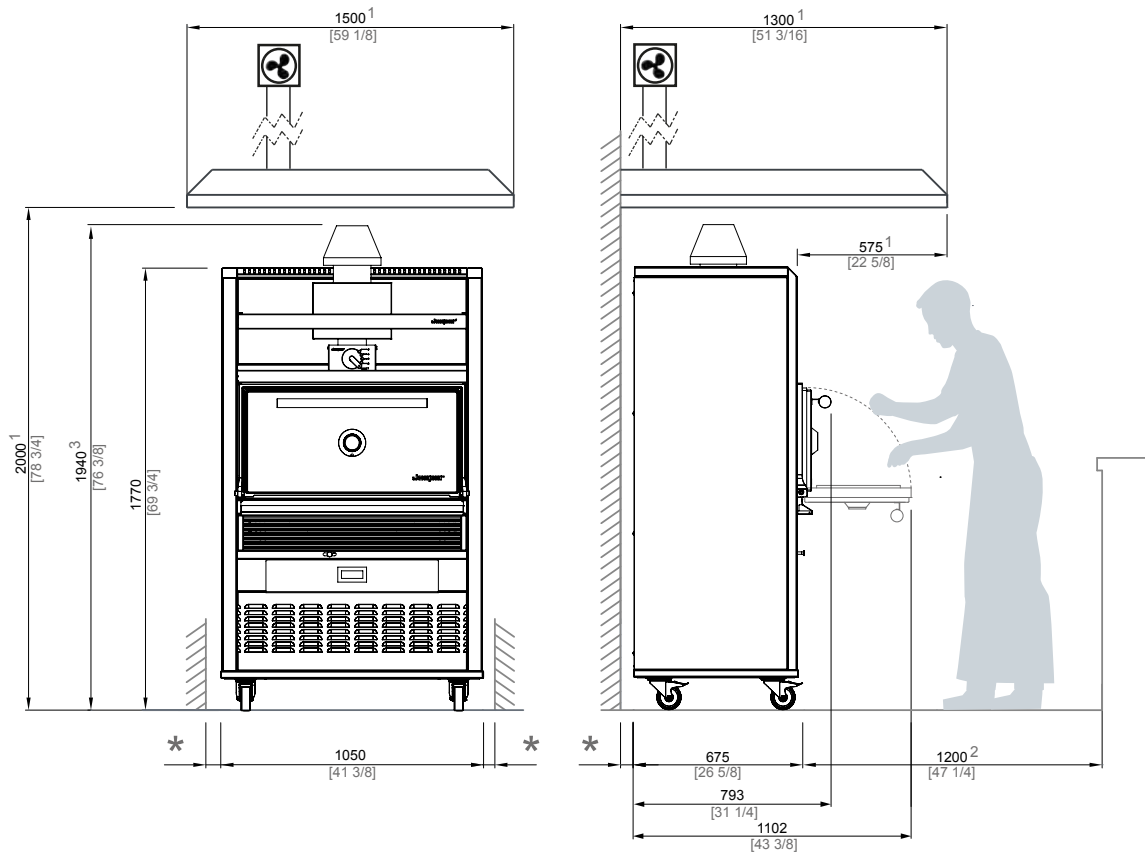
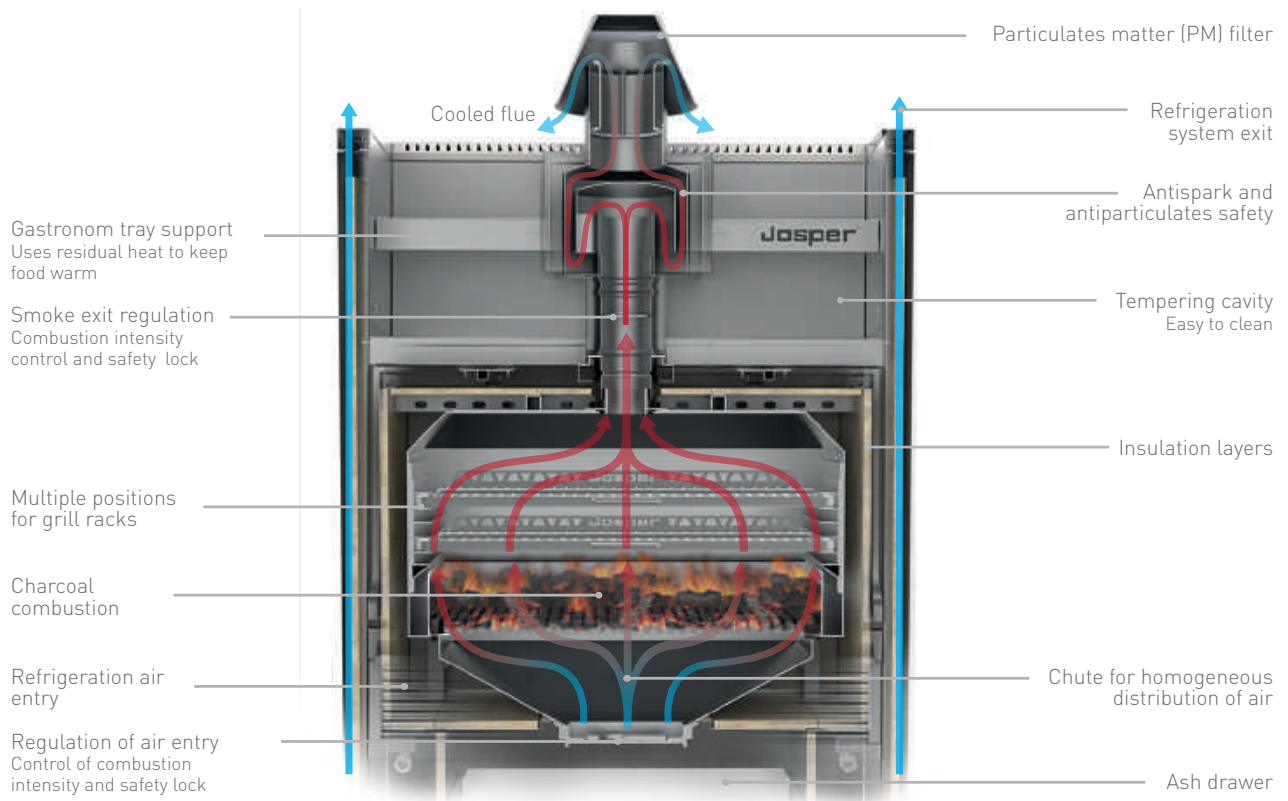

* MINIMUM DISTANCE TO FLAMMABLE ELEMENTS: 300 mm [12 in] / RECOMMENDED DISTANCE TO ANOTHER ELEMENTS: 100 mm [4 in]

1 RECOMMENDED HOOD'S MINIMUM DIMENSIONS

2 RECOMMENDED CHEF'S WORKING SPACE

3 THIS DISTANCE MAY BE MODIFIED BY THE SMOKE OUTLET SET CONFIGURATION.

[mm
in]