

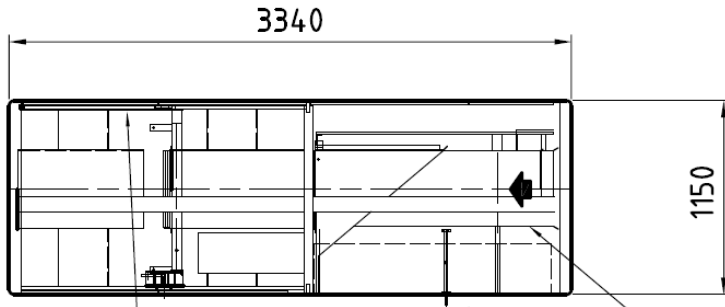

LAYOUT

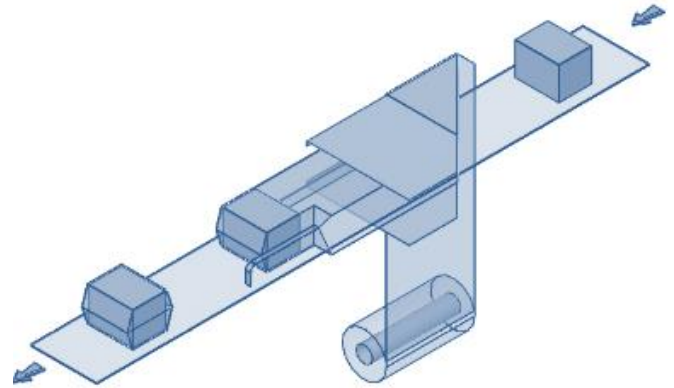

PRODUCT FLOW



SELECTION OF PACKAGING VARIATIONS

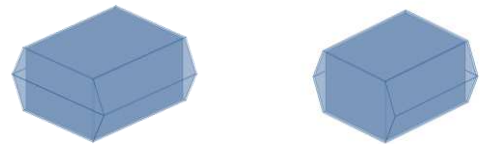

DESCRIPTION

This is an automatic wrapping machine with a continuous side sealing system for packing a large variety of small and medium industrial products both with P.E or P.P. film. It can pack shrunk packs if combined with a shrink tunnel.

TECHNICAL SPECIFICATIONS

Product Dimensions		Min	Max
Width	mm	25	380
Length		150	6000
Height		25	300
Mechanical Speed	Up to 30 packs/min		

OTHER TECHNICAL SPECIFICATIONS

Wrapping material	Polypropylene (P.P.) of 11-25μ pre-perforated film C-Folded film reel
	Polyethylene (P.E.) of 26-60μ pre-perforated film C-Folded film reel
Final packaging result	Fully closed pack with a lateral lengthwise welding, two horizontal front/back weldings (shrink-wrapped / optional)

MATCHABLE UNITS/OPTIONALS

Extra Pack Format	<input type="checkbox"/>	Optical barrier for not uniform and/or particular shaped products	<input type="checkbox"/>
Film reel pre-end alarm	<input type="checkbox"/>	Shrink tunnel 50-30SR or 50-30DR	<input type="checkbox"/>
Configuration for PP film	<input type="checkbox"/>	Silicon rods for shirink tunnel	<input type="checkbox"/>
Printed registration film unit	<input type="checkbox"/>	Remote connection module	<input type="checkbox"/>
Vertical photocell for small products	<input type="checkbox"/>		