



NORDENMATIC 702

NORDEN

a coesia company

FLEXIBILITY & RELIABILITY

There's a reason the Nordenmatic 702 is the top selling tube filling machine on the market: it's designed to deliver. With production outputs of up to 80 tubes per minute you get maximum productivity with the highest possible packaging quality standards at maximum operational efficiencies. The NM 702 is able to handle a wide range of tube sizes, from 10 mm to 60 mm, whether they are plastic, laminate, or aluminium.

The machine is equipped with 22-tube holder links as standard, while our well-proven oval tube transport system, which facilitates good machine access and smooth integration of new equipment, is available in clockwise or anti-clockwise versions, allowing you to choose the most efficient line layout to best suit your factory and production needs.



Main technical features

- Norden EasyWare control system.
- Hot Air Sealing
- Design-A-Seal®, Swirl filling and Scoop Seal®
- Metal Folding or Combination Sealing
- Prepared for multi-color filling
- Clockwise or anti-clockwise operation
- Jogging device
- Servo driven functions (option)

Get in touch with a Norden sales representative to calculate the impact the NM 702 could have on your business.



Infeed Systems

The NM 702 can be fitted with a number of infeed systems, including semi-automatic in-feed with storage capacity and complete with motorized sorting device, an ergonomic system for loading complete tube transport boxes at a convenient height for machine operators, and a robot tube loader that assures the best possible line efficiency and which is suitable for both small and large tube diameters, even most oval tubes.



Operation Cycle

The NM 702 is available in both clockwise and anti-clockwise versions. While 22 tube holders are standard, extension to 28 is possible for additional equipment. The machine table is manufactured in stainless steel for long-term durability.



Hot Air sealing system

Norden's highly efficient and patented Hot Air sealing beam can handle all your plastic and laminate tubes. It has a quick disconnect of the hot air nozzle and cooling ring block, and includes counters and scales for fast and repeatable changeovers. The system is the strongest and most attractive way of sealing tubes, and yields very little waste.

Combination Sealing Unit

The combination sealing unit allows you to switch between plastic/laminate and metal tubes on one machine. Usually, switching complete metal and hot air beams takes up several hours of your valuable production time. But with our combination beam on your Norden filling machine, you can switch from hot air to metal sealing in 15 minutes without any tools.

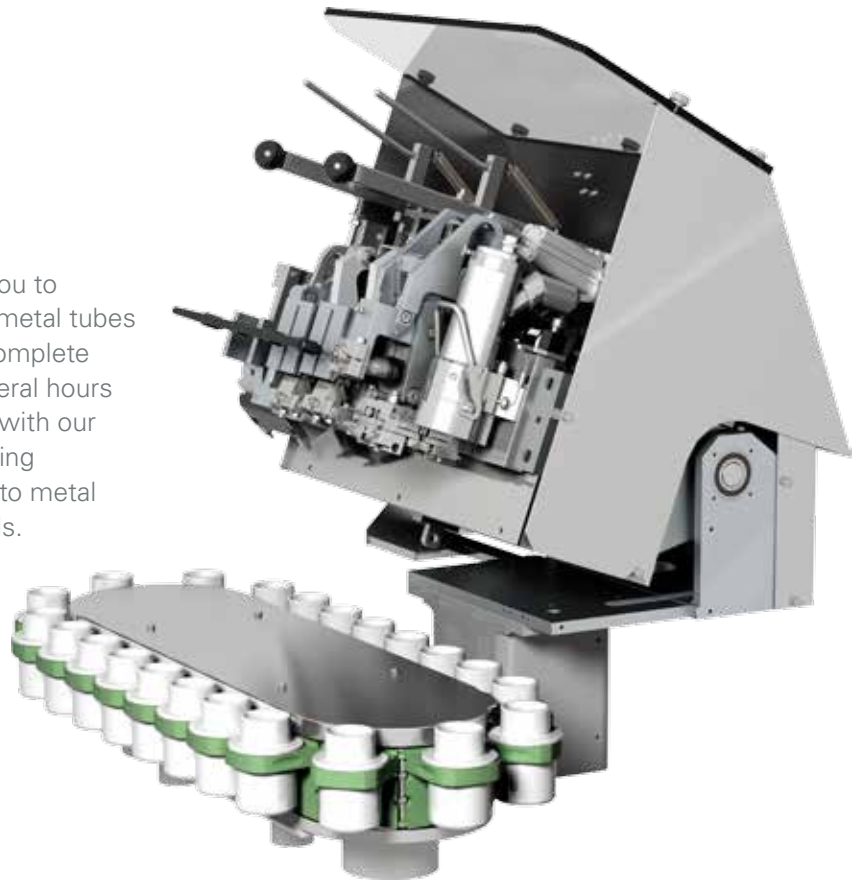

Access & Control

With machine technology becoming ever more complex our user-friendly Norden EasyWare interface makes controlling and monitoring the NM 702 a snap, whilst still meeting all of your performance and quality demands. The control system features a 10" color screen and allows 50 pre-programmed format tables that, together with improved access for maintenance, reduce changeover time to a minimum.

Customer Care With all the Benefits

Getting your NM 702 tube system up and running perfectly is not the end of our commitment to you. We will continue to actively support you to maintain peak performance throughout the machine's lifecycle.

We achieve our customer care through a portfolio of after-sales services, from which you can choose those best suited to satisfy your needs during the different stages of your long-term production.

Norden customer care

- Customer training
- Performance services
- Spare parts
- Machine upgrades
- Design & documentation support
- Technical service support

VERSATILITY & INNOVATION

Norden understands that one size does not fit all, so we offer a full complement of options, each designed to help you get the most out of your tube filling machine by boosting your production edge.

Whether it's welding options or high performance design, our machines can be optimized to best suit your needs.

Design-A-Seal®

Design-A-Seal® makes it possible to alter the appearance of tubes without compromising production output or seal integrity. Design variations include rounded, angular, or wide shapes, which can all be considered and incorporated into the package design.

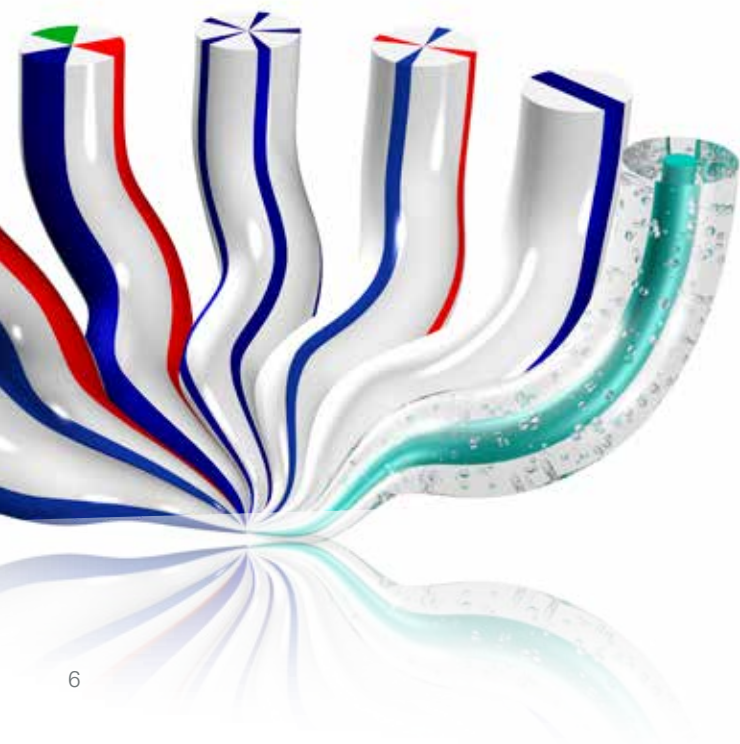

Multi-color filling

This is the filling of multiple colors at the same time into one tube, typified by 3-color striped toothpaste. The striking look is achieved by three multiple pumps pumping the different colors through one complex filling nozzle, thus creating the eye-catching striped product.



Scoop Seal®

Scoop Seal® has an ergonomic design which provides the perfect grip to squeeze all of the product from the tube. Its compact design allows more space in each tube tray and pallet, maximizing storage capacity.

Swirl Filling

Our latest innovation, Norden Swirl Filling, offers you even more possibilities to develop new, unique and exciting products. The system is extremely flexible, utilizing servo motors to control the filling operation, tube lift at filling and the rotation of the tube, which means the filling profile can be optimized to suit the product while giving exact control for superb visual effects.



TECHNICAL INFORMATION

TUBE SEALING OPTIONS



Hot Air sealing

For plastic and laminate tubes.



Scoop Seal®

For plastic and laminate tubes.



High Frequency sealing

For aluminium-laminate tubes.



Metal folding

For aluminium tubes.

Metal folding types



1.



2.



3.



4.

SPECIFICATIONS

Running capacity (max tubes/min) ¹	80
Filling volume ²	1–300 ml
Dosing accuracy	±0,1–0,5 %
Tube length	50–250 mm
Tube diameter ⁶	10–60 mm

Shipping specifications	NM 702	Store Magazine (NSM 180)
Net weight, approx.	2000 kg	300 kg
Gross weight (case), approx.	2400 kg	500 kg
Volume, approx.	11,8 m ³	3,7 m ³

	M	HF	HA
Power consumption (max, kW)	2	8	6
Air consumption ⁴ (Nm ³ /h)	10	15	40–70 ³
Water consumption ⁵ (l/min)	–	3	4

1 Depending on tube size, filling product and quality of tube and filling material.

2 An optional design for filling volumes up to 600 ml is available on request.

3 Depending on tube size and material.

4 Air pressure MPa 0,6 (6 bar).

5 Water pressure – min 2 bar in to the machine and max 0,5 bar counter pressure at water outlet.

6 Tube diameters >Ø50 special equipped machines are needed.

OPERATION CYCLE

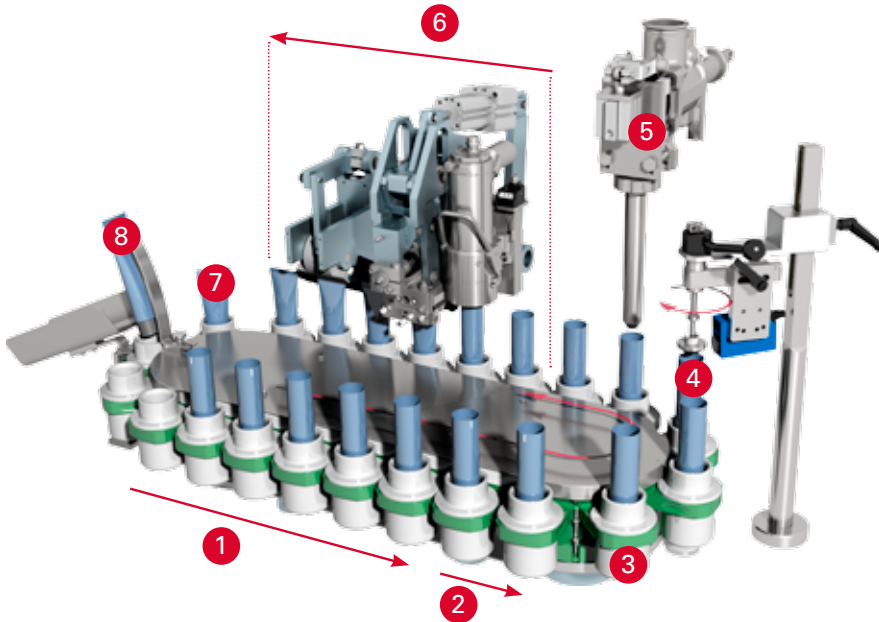

Anti-clockwise version

- 1. Alternative tube infeed equipment
- 2. Available for extra equipment
- 3. Tube cleaning and cap tightening
- 4. Tube checking and tube print orientation
- 5. Filling
- 6. Alternative sealing equipment
- 7. Available for reject of faulty tubes or extra equipment like laser/inkjet
- 8. Discharge

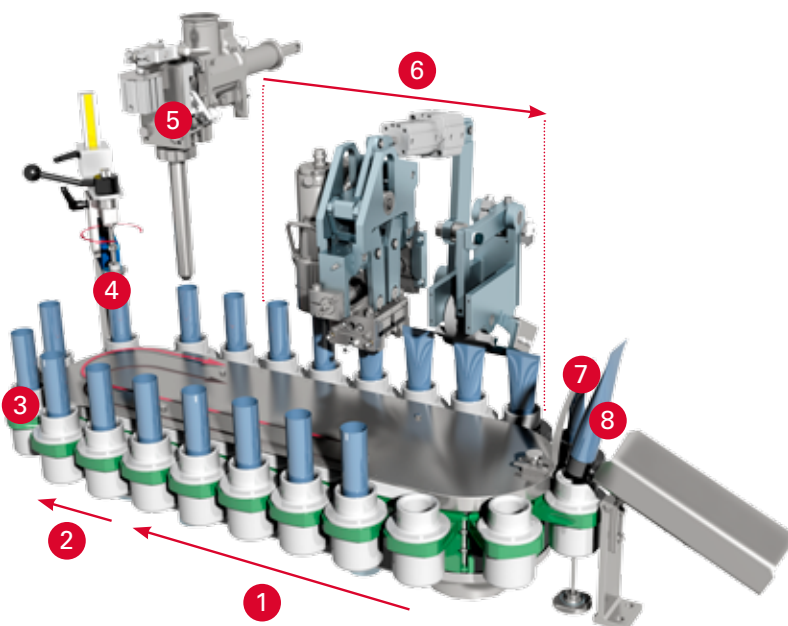

Clockwise version

- 1. Alternative tube infeed equipment
- 2. Available for extra equipment
- 3. Tube cleaning and cap tightening
- 4. Tube checking and tube print orientation
- 5. Filling
- 6. Alternative sealing equipment
- 7. Available for reject of faulty tubes or extra equipment like laser/inkjet
- 8. Discharge

MACHINE LAYOUTS

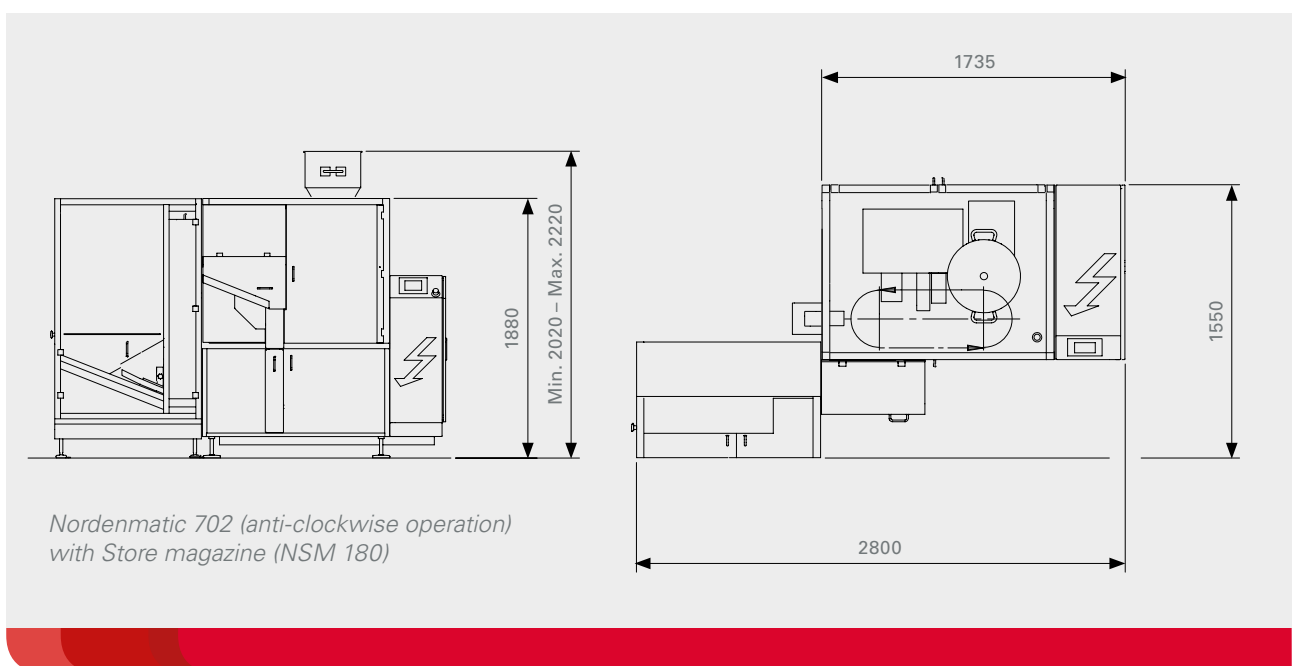
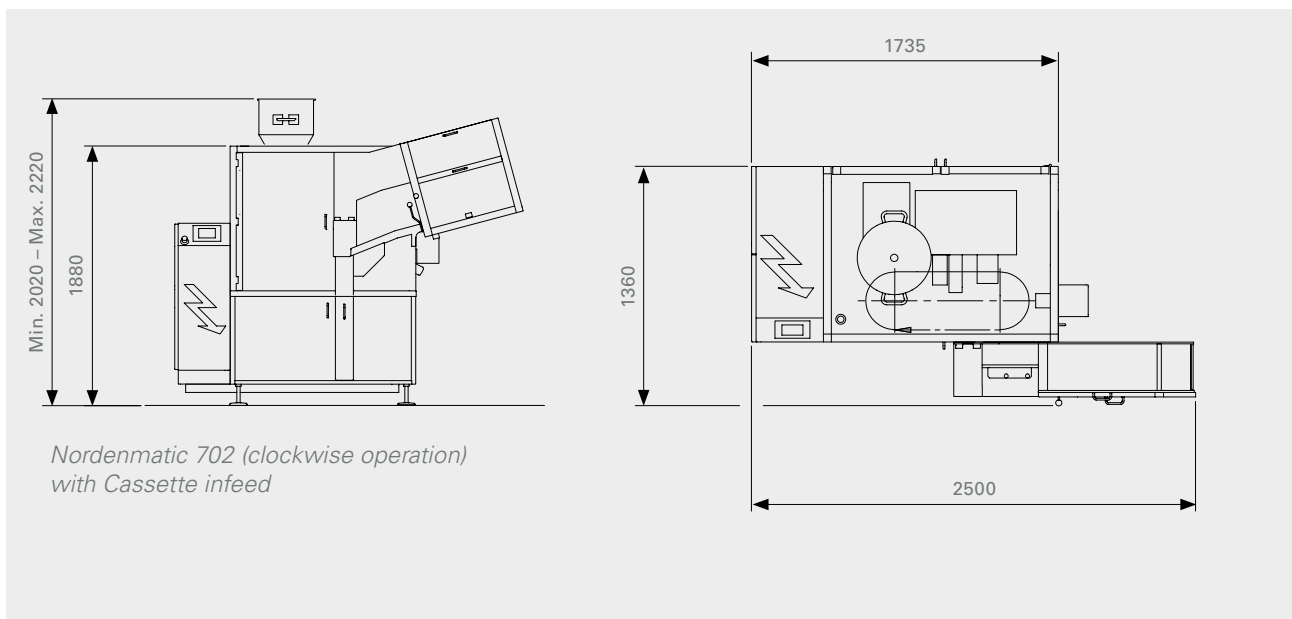

EQUIPMENT OVERVIEW – STANDARD CONFIGURATION

Equipment

- All major machine surfaces and operating units made of stainless steel. Plexiglas PMMA doors and covers above machine table
- Semi-automatic tube infeed with an inclined chute, and a vacuum assisted tilter mechanism and push rod for automatically inserting tubes into the tube holder chain
- One volumetric pump unit in stainless steel. Parts in contact with the fill product are made of ASTM 316L (DIN 1.4404, BS 316S12 or SIS 2348).
- Size parts for one tube and one fill product

Available sizes:

Filling volume (ml)	Piston dia. (mm)
1–5	15
1,5–14	20
3,5–50	30
15–165	45
25–300	60

Available nozzle types:

Blow-off
Cut-off
Combination blow-off, cut-off

- Oval racetrack with tube transport raised to facilitate cleaning of machine table
- Tube holder links lined with Teflon and furnished with magnets to ensure that the tube holders remain in the same position in the links during indexing. 22 tube holders in the tube transport is standard. (Tube holder design depends on tube size, material, cap design and required machine speed. We can help you determine the specific type based on delivered tube samples.)

- One set of emergency spare parts and tools
- Machine manufactured in accordance with European electrical standard EN 60204-1

Main functions

- Photoelectric tube print registration station, ensuring correct positioning of the tube decoration prior to sealing.
- Bottom-up filling
- Electrical variable machine speed
- Jogging device with low speed forward
- Tube orientation. Tubes may be stopped in any position through 360 degrees. Stop position set from the operator panel.
- Cycle stop in the most favourable position
- One side coding of 6 characters, digits 0 through 9, with a total of 60 characters per channel

Safety functions

- Control functions, error reporting and overload protection for tube indexing operation. Should an error occur, the machine is stopped and the error reported on the operator panel. Minor faults are registered and reported. The number of consecutive faults allowed before the machine stops can be set from the operator panel.
- Electronic guard switches. All doors pneumatically interlocked during operation.
- Alarm signalling system with a three-color lamp and buzzer
- Emergency stop button

Operator panel

- 10" color touch screen panel utilizing Norden EasyWare, based on ELAU electrical control system
- Line status information
- 50 programmable format tables
- 16+16 freely programmable functions
- Production statistics (OEE) on operator panel
- All alarms reported and described. Indicators may be pre-programmed by the customer.
- Operator panel functions secured by 7 different access levels
- Power supply for main controller backed up by UPS

OPTIONS

Infeed

- Cassette infeed system. Individual cassettes tailored to each carton size.
- Hinged cassette infeed system
- Robot infeed system
- Norden Store Magazine

Tube Control

- Tube cleaning with diving air blow nozzle and air evacuation.
- Code reading system
- Tube holders with steel teeth for exact tube orientation.
- Cap tightening
- Cap control stations. If a cap is missing the tube will be marked faulty.

Product Feeding

- Product level control
- Heated product hopper
- Stirring device
- Pressure equalizing system

Filling

- Complete extra pump unit to allow fast product changeover
- Overload protection for the filling pump
- Clean in place (CIP)
- Sterilization in place (SIP)
- Hoist system for wet parts
- Inert gas injection before and/or after filling

Sealing and coding

- Hot Air sealing unit for plastic, plastic-laminated and aluminium-laminated tubes.
- Plain or crimped closure
- Tilttable sealing unit
- Design-A-Seal® sealing unit for plastic and plastic-laminated tubes. One seal shape.
- Kits for quick changeover of coding unit
- Unit for coding on both sides of the tube
- Corner trimming device

Discharge

- Pick & Place unit for direct transfer to cartoner
- Cap first discharge for line configurations

General

- Size parts for additional tube sizes and/or products
- Central lubrication
- Energy save
- Validation
- Individual indication of open doors



coesia

coesia.com

Coesia is a group of innovation-based industrial solutions companies operating globally, headquartered in Bologna, Italy.

Coesia's companies are leaders in the sectors of:

- **Advanced automated machinery and materials**
- **Industrial process solutions**
- **Precision gears**

Coesia's customers are leading players in a broad range of industries, including Consumer Goods, Tobacco, Healthcare, Aerospace, Racing & Automotive and Electronics.

NORDEN

a coesia company

Get **more**
out of **tubes**

nordenmachinery.com

NORDEN MACHINERY AB
P O Box 845
SE-391 28 Kalmar
Sweden
T (+46) 480 44 77 00
sales@nordenmachinery.se