

Checkweigher Flexus®

Hygienic design meets flexibility and maximum performance

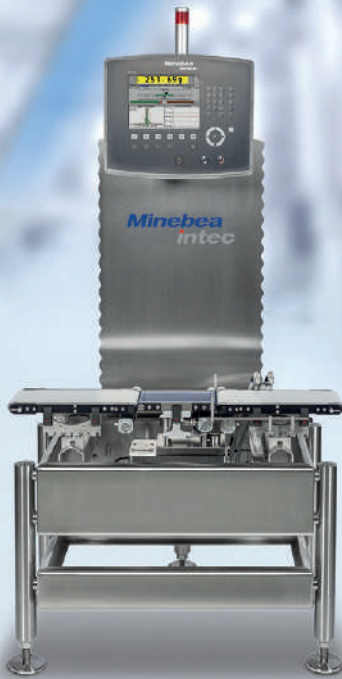

Now
MID approved
for up to
3 m/s

! Advantages

- Hygienic design for easy cleaning and the highest level of quality in your production operations
- Safety and reliability thanks to EMFC load cell technology
- The ideal solution every time – configure Flexus® for your application
- Easy to combine with metal detection technology Vistus®



The Checkweigher Flexus® meets the strictest requirements when it comes to hygienic design guidelines for packaged foods. A wide range of configurations ensure that every requirement is covered.

The Checkweigher Flexus® for product quality and food safety

- ① Flexus® is your solution for ensuring optimum product quality, regardless of whether you want to **check the weight** and/or **integrity of your product** or optimise **your filling processes**.
- ① Flexus® is easy to integrate into your production environment. Changes to line configurations and quick transitions between products are handled **quickly and easily**.
- ① Specifically designed for the food industry, Flexus® enables easy inspection, as well as **simple and safe cleaning**.
- ① The high-resolution **EMFC load cell technology** and a **tailored design** guarantee precise weighing results and a high throughput of up to 600 pieces per minute.

Flexible – hygienic – high-performance

The Checkweigher Flexus® has been specially developed to comply with guidelines and standards such as IFS and BRC. It is approved for use in legal metrology for FPV (German Prepackages Act) checks, and is MID-compliant in accordance with OIML R51. Thanks to its intelligent, modular construction and hygienic design, the Flexus® can be configured to suit your individual requirements, providing you with the ideal solution for any challenge you face.



As a member of the EHEDG, we develop our products based on a wide range of hygienic design guidelines.

Technical data – Flexus®

The results achievable in practice, e.g. for the standard deviation attributable to measurement error or the throughput, depend on the relevant application.

Weighing system	WS 1 kg	WS 2 kg	WS 5 kg	WS 7 kg
Gross weighing range [g]	Up to 1,000	Up to 2,000	Up to 5,000	Up to 7,000
Smallest permissible calibration value [g]	0.1	0.2	0.5	1
Standard deviation attributable to measurement error (s) [mg]	From 17	From 83	From 250	From 333
Throughput [pcs/min]	Depends on product, throughput, ambient conditions and area of application			
	Max. 600	Max. 550	Max. 450	Max. 450
Standard speed ranges [m/s]	Depends on version, product, permissible imprecision, ambient conditions and area of application			
	0.2 to 1.5 m/s 0.5 to 2.6 m/s	0.2 to 1.0 m/s 0.5 to 2.2 m/s	0.2 to 1.0 m/s 0.5 to 1.9 m/s	0.2 to 1.0 m/s 0.5 to 1.9 m/s
	Higher speeds available on request, MID verifiable systems up to 3 m/s			
Centre-to-centre distance of weighing belt [mm]	210/310	300/350/400/450/500		
	See scale drawing and 'Versions' table			
Belt width [mm]	See 'Versions' table			
Weighing belt roller diameter [mm]	22	30		
Drives	Maintenance-free 24 V EC motors with planetary gear Motor control, short-circuit-proof with temperature monitoring			
Supply voltage	115/230 V _{ac} (+10%/-15%); 50/60 Hz (L1, N, PE) switchable			
Power consumption	Approx. 600 VA			
Operating pressure	Default setting: Pusher: approx. 3 bar Blower: approx. 5 bar			
Feed direction	Right to left or left to right (please indicate when ordering)			
Working height* [mm]	500 to 1,400 with standard adjustable feet 575 to 1,475 with hygienic adjustable feet (adjustable foot range +/-25) * Working height below 650 mm results in limited floor clearance when combined with the collection container option			
Floor clearance [mm]	200 with adjustable foot range +/-25 (standard) 275 with adjustable foot range +/-25 (hygienic adjustable feet)			
Permissible operating temperature range [°C]	0 to +40 (MID +5 to +40)			
Conveyor system temperature range [°C]	-10 to +100 (WS 1 kg, belt) -30 to +70 (WS 1 kg, round belt) -30 to +80 (WS 2 to 7 kg, belt)			
Protection class	IP 54 (standard), IP 65 (optional)			
Dimensions	See scale drawings			
Weigher frame material	Stainless steel 1.4301			
Weight	250 kg to 400 kg, depending on version			
Airborne noise emitted	A-weighted sound pressure level emitted < 70 dB(A)			
Inputs	8/16 (optional) digital inputs, 24 V inputs galvanically isolated with a relay or with optocoupler, depending on use			
Outputs	8/16 (optional) digital outputs, 24 V outputs galvanically isolated with a relay or with optocoupler, depending on use 2 analogue outputs, 0–20 mA, 0–10 V, for analogue trend controller option Voltage output: Load ≥ 2 kΩ Current output: Load ≤ 300 Ω			

Technical specifications – Checkweigher Flexus®

Create your individual Checkweigher Flexus® from a wide range of options and function enhancements. We'd be happy to advise you!

Checkweigher Flexus® – standard	
Dialogue PC	Flexus® 10: 10.4-inch TFT colour display with keypad
Weight display	choice of gross, net or differential weight
Operational display	Choice of distribution, yield, throughput, average value chart, large weight readout
Operating modes	Classifying weigher with AWC evaluation; freely selectable class limits; 3-way or 5-way classifying/sorting; statistics with logging of all products; load cell with EMFC technology; product data memory for 200 products; choice of languages for program dialogues, user-selected; self-monitoring via error report; auxiliary functions: dialogues for diagnostics and service, data stored in battery-backed memory, batch mode, automatic zero-setting of the load cell, program-controlled belt speed
Digital input	Hide weigher, event counter, external error message
Digital output	Feeder/batch, 3-way/5-way sorting, total counter/pre-selection counter, error message output, time-unit-controlled sorting
Separation system	One separator including: pusher or blower (depending on product size)
Weighing belt	Various lengths and widths

Checkweigher Flexus® – optional for increased requirements			
Connectivity	Fieldbus	PROFIBUS-DP, PROFINET IO, DeviceNet, Ethernet/IP	
	Data communication		
	Factory bus TCP/IP, Ethernet, Ethernet/IP	XML client, XML server, prepared for SPC@Enterprise and OPC DA server	
	Individual weight value output for external evaluation and connection to customer systems	Serial interface RS 422, RS 232 or current loop	
	All interfaces specified here are free from feedback and do not need to be secured		
Software/programs	SPC@Remote	Remote control for checkweigher – suitable for many different applications	
	Filling spout evaluation	Statistics for each filling spout and overall statistics possible	
	Calibration approval	Verifiable in accordance with OIML R 51 - MID	
	Control functions	Integrity checking/with floating mean value, measuring accuracy check by entering package control weight, automatic sampling of packaging for checking upstream filler	
		USB printing	
	Logging system for external printer		
	Volume evaluation	Without air buoyancy correction, with air buoyancy correction	
Trend controller with display	3-point controller +/- control signal, 3-point controller with pulse packet, integral controller 0–20 mA/0–10 V		
User-defined access control (audit trail) as per FDA 21 CFR Part 11	Specifications according to FDA requirements (Food and Drug Administration) for data stored electronically and electronic signatures		
Control	3-way/5-way classifying display	3-way signal light, 5-way signal light, isolated outputs, isolated outputs with 3-way signal light, isolated outputs with 5-way signal light	
	Separation system	Control of customer sorting/separating equipment	
	Monitoring functions		
	Compressed air monitoring	Isolated output, belt stop	
	Separation monitoring	Isolated output	
	Goods flow	Isolated output with belt stop	
	Package length/interval monitoring	Using additional light barrier	
	Fill level monitoring		
	Collection container	Isolated output with light	
	Incorrect weight		
	Production monitoring	Monitoring of average value and repetitive rejections	
Sorting with path cycle/displacement sensor			
Mechanical designs	Dialogue PC	Flexus® 15: TFT colour 15.0 inch, touchscreen	
	Emergency stop button	Built into PC panel	
	Incorrect weight collection container	Made from plastic (for products up to 500 g and a maximum belt width of 200 mm) or stainless steel	
	Separation systems	Rocker, swivel arm, multi-segment separator	
	Transfer runways	Only for WS 1 kg/2 kg – up to a belt width of 200 mm	
	Options	Wind protector, covers, LEDs, horn, IP65, guide rail, side-grip belts, stand-alone load cell and weighing belt, separate installation of weighing system and electronics with display and remote terminal, multiline systems, hygienic adjustable feet, additional infeed belt or outfeed belt, pneumatics in stainless steel housing	

Scale drawings

Front view

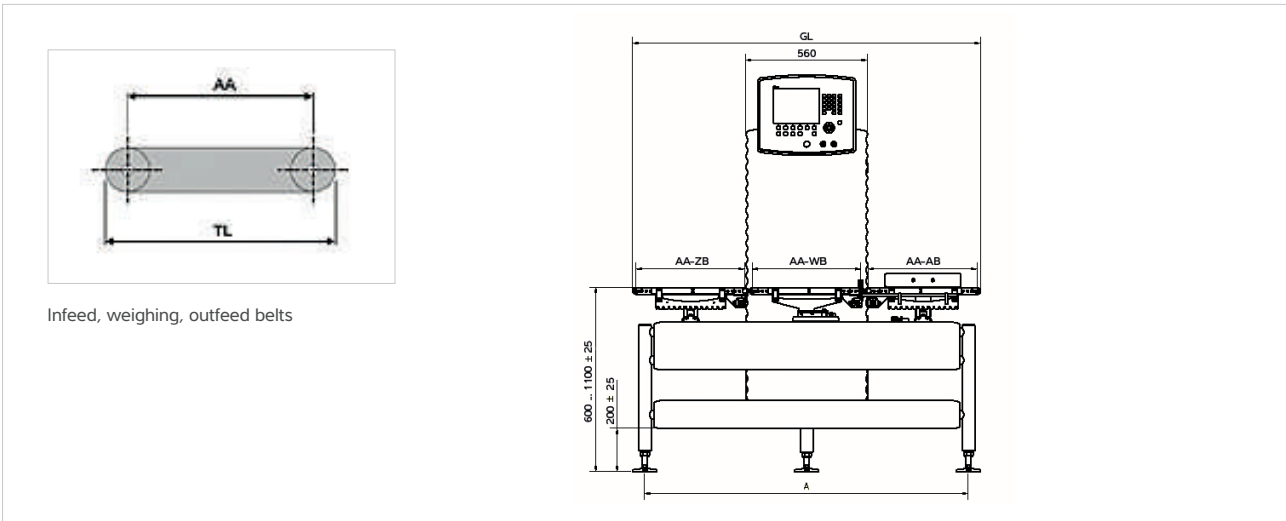

Infeed, weighing, outfeed belts

AA-ZB	Centre-to-centre distance of infeed belt [mm]
AA-WB	Centre-to-centre distance of weighing belt [mm]
AA-AB	Centre-to-centre distance of outfeed belt [mm]
GL	Total length [mm]
A	Foot distance [mm] (=GL-110)
TL	Platform length [mm] TL = AA + roller diameter (30 mm, or 22 mm in the case of the 1 kg weighing belt)

Dimensions table: WS 1 kg

AA-ZB	AA-WB	AA-AB
350/400/450/500	210	350/400/450/500
300/350/400/450/500	310	300/350/400/450/500
Total length GL = AA-ZB + AA-WB + AA-AB + 90		

Dimensions table: WS 2/5/7 kg

AA-ZB	AA-WB	AA-AB
300/350/400/450/500	300	300/350/400/450/500
350/400/450/500	350	350/400/450/500
400/450/500	400	400/450/500
450/500	450	450/500
500	500	500
Total length GL = AA-ZB + AA-WB + AA-AB + 100		

For belt widths BB = 150/200/250/300, additional lengths are available for infeed and outfeed belts with centre-to-centre distance AA = 550/600/650/700. This creates a larger overhang in relation to the base frame (AA-500+95).

Side view

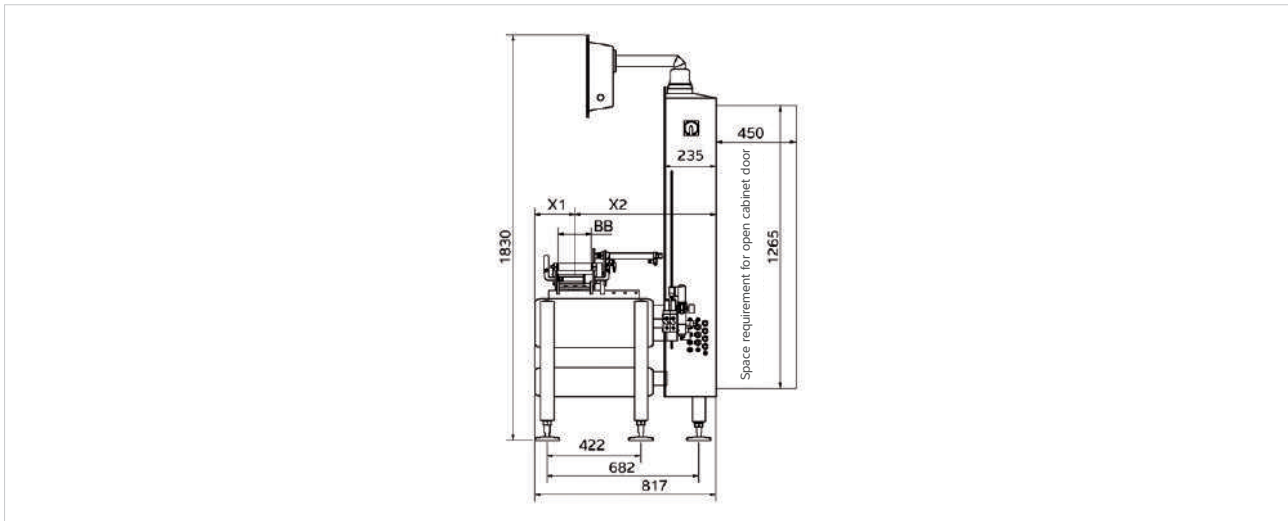

BB	Belt width [mm]
X1	Variable; see scale drawing
X2	Variable; see scale drawing

	BB	X1	X2
WS 1 kg	50	183	634
	100	183	634
	150	183	634
	200	208	609
WS 2/5/7 kg	150	183	634
	200	208	609
	250	233	584
	300	258	559

Versions

AA	Centre-to-centre distance [mm]
BB	Belt width [mm]
●	Round belt or belt version
■	Belt version

Dimensions table: WS 1 kg

BB x AA [mm]		
Infeed belt ■	Weighing belt ●	Outfeed belt ■
150 x 350/400/450/500	50 x 210	150 x 350/400/450/500
150 x 350/400/450/500	100 x 210	150 x 350/400/450/500
150 x 350/400/450/500	150 x 210	150 x 350/400/450/500
200 x 350/400/450/500	200 x 210	200 x 350/400/450/500
150 x 300/350/400/450/500	50 x 310	150 x 300/350/400/450/500
150 x 300/350/400/450/500	100 x 310	150 x 300/350/400/450/500
150 x 300/350/400/450/500	150 x 310	150 x 300/350/400/450/500
200 x 300/350/400/450/500	200 x 310	200 x 300/350/400/450/500

Dimensions table: WS 2/5/7 kg

	AA [mm]	Weighing belt	Outfeed belt
BB	Infeed belt ■	Weighing belt ■	Outfeed belt ■
150	300/350/400/450/500	300	300/350/400/450/500
	350/400/450/500	350	350/400/450/500
	400/450/500	400	400/450/500
	450/500	450	450/500
	500	500	500
200	300/350/400/450/500	300	300/350/400/450/500
	350/400/450/500	350	350/400/450/500
	400/450/500	400	400/450/500
	400/450	450	450/500
	500	500	500
250	300/350/400/450/500	300	300/350/400/450/500
	350/400/450/500	350	350/400/450/500
	400/450/500	400	400/450/500
	450/500	450	450/500
	500	500	500
300	350/400/450/500	350	350/400/450/500
	400/450/500	400	400/450/500
	450/500	450	450/500
	500	500	500

Collection container

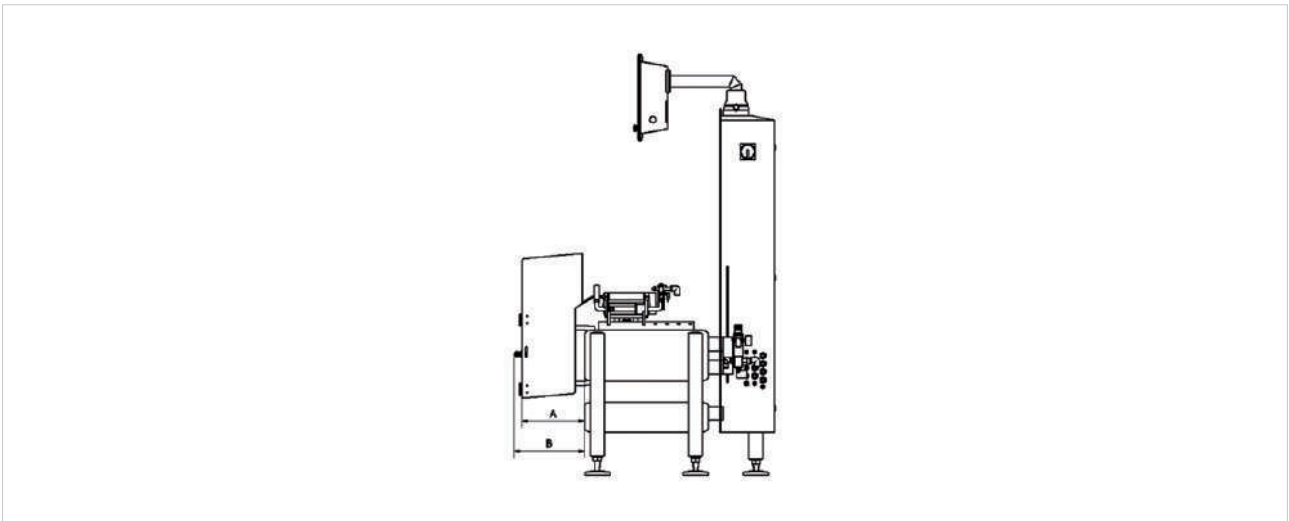

The scale drawing shows Flexus® with a collection container (optional), which is made from plastic or stainless steel – both versions have different dimensions.

A: Minimum depth of the collection container

B: Maximum depth (incl. key) of the collection container

Material	A [mm]	B [mm]
Plastic	272	303
Stainless steel	372	403

Product description

Machine construction

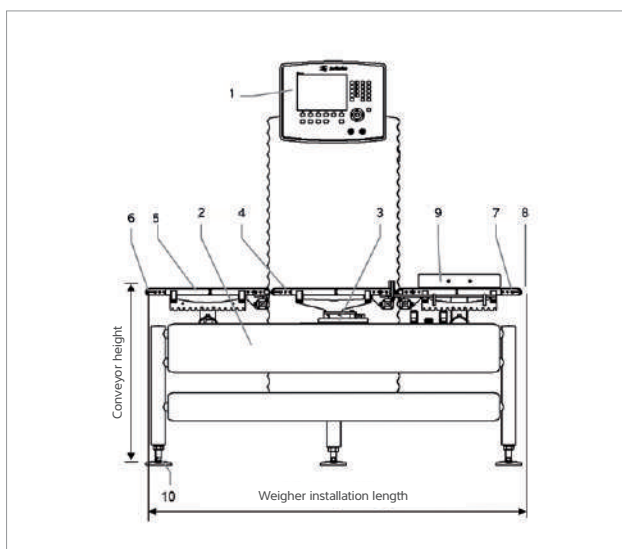

- 1 Display and remote terminal
- 2 Weigher frame
- 3 Load cell
- 4 Weighing belt
- 5 Infeed belt
- 6 Connection to customer infeed belt
- 7 Outfeed belt
- 8 Connection to customer outfeed belt
- 9 Separator
- 10 Spindle adjustable feet

Product description

Machine construction

A three-part conveyor belt system transports the products. All conveyor belts (4, 5, 7) in the system run at the same speed to ensure that products are transferred smoothly onto and off of the weighing belt. The weighing process is carried out dynamically and automatically without intervention by operating personnel. The weight value, including mass unit, is converted and shown on the display.

Weigher frame with control cabinet

Crossbars are fitted to the weigher frame (2). The weighing and transport system is attached to these crossbars. The pillar cabinet with its sinusoidal housing profile is attached to the weigher frame using a clamping device in a form-fitting manner. The working height of the weigher frame is determined by the length of the frame legs. The working height can be adjusted by changing or modifying the frame legs. Small adjustments to the working height can be made via the spindle adjustable feet (10). The display and remote terminal (1) is installed in front of the control cabinet.

Load cell

The load cell (3) is a monolithic, electro-magnetic force compensation load cell (EMFC). This delivers maximum precision, extremely short settling times, high long-term stability and overload protection in a stainless steel housing.

Transport system

A conveyor belt is used as the transport medium (weighing belt WS 1 kg also available with round belt). The belt frame is equipped with a belt quick-clamping device and a hinged, removable transport system. This allows the conveyor belts to be removed/fitted and replaced without tools. The infeed, weighing and outfeed belts are each driven by an EC geared motor. Power is transmitted via toothed belt.

- The infeed belt (5) takes products from the upstream machine and transports them to the weighing belt.
- The weighing belt (4) takes the products from the infeed belt. As the products travel along the weighing belt, they are weighed while they move.
- The outfeed belt (7) takes the products and moves them on.

Control electronics

The display and remote terminal for the weighing function is based on an industrial PC with a powerful 32-bit multitasking operating system with data storage on an internal wear-free compact flash memory card. The housing is made from polished stainless steel. The control cabinet is opened using a continuous cabinet door opening to the rear with fasteners.

The connection terminals for the power supply, the components of the evaluation and display electronics and the power supply unit with motor control are housed in the control cabinet. The main switch is installed in the control cabinet. The start/stop button for the transport system is located on the front of the display and remote terminal (1), which can be swivelled for ergonomic operation.

Separator (9)

Two compressed air nozzles (standard WS 1 kg) or a pneumatic pusher (standard WS 2–7 kg) are fitted on the crossbars of the weigher frame in the outfeed belt area to ensure the reliable rejection of products that have a different weight. A filter pressure control valve is included.