



Features

- Hardox Bale Chamber
- CAT3 Electrical Safety
- Touchscreen HMI
- Remotely Programmable
- Wire coil dispensers
- Raised bale floor for ease of cleaning
- Interlocked maintenance access doors
- Wire pusher can be placed on either side
- Multi-Linkage jaw clamp for denser bales

Optional Extras

- Feed conveyor
- De-blocking Ram
- Newsprint/Paper Fluffers
- Bin Lifter feeding
- Vertical wire pusher
- Vertical & Horizontal ties
- Bale exit guides
- Hardox upgrades

Dimensions

Height	3 204mm
Width	4 130mm
Length	10 409mm
Feed Opening	2 400mm x 1 020mm

Bale Dimensions

Height	1 100mm
Width	1 100mm
Length	Variable
Bale Weight	800 - 1 500kg
Number of ties	5
Wire Size	2.8mm - 4mm

Performance

Motor	80HP	120HP	180HP
Oil Reservoir	2000L	3000L	4000L
Throughput (TPH)	12-18	15-20	20-25
Machine Weight	24T	25T	27T
Power Supply	415 V 3-Phase		
Pressing Force	120T (optional 150T)		



Dimensions and technical information without obligation. Subject to change.

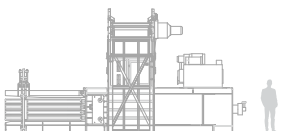
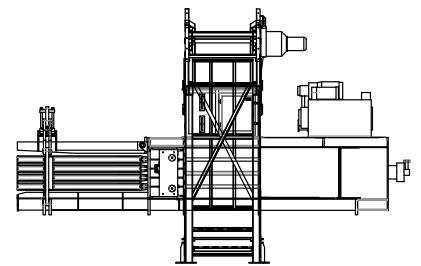
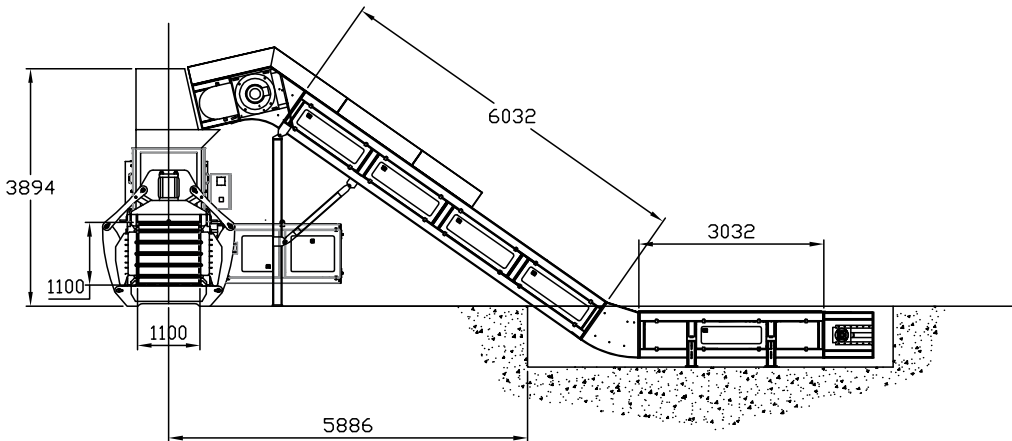
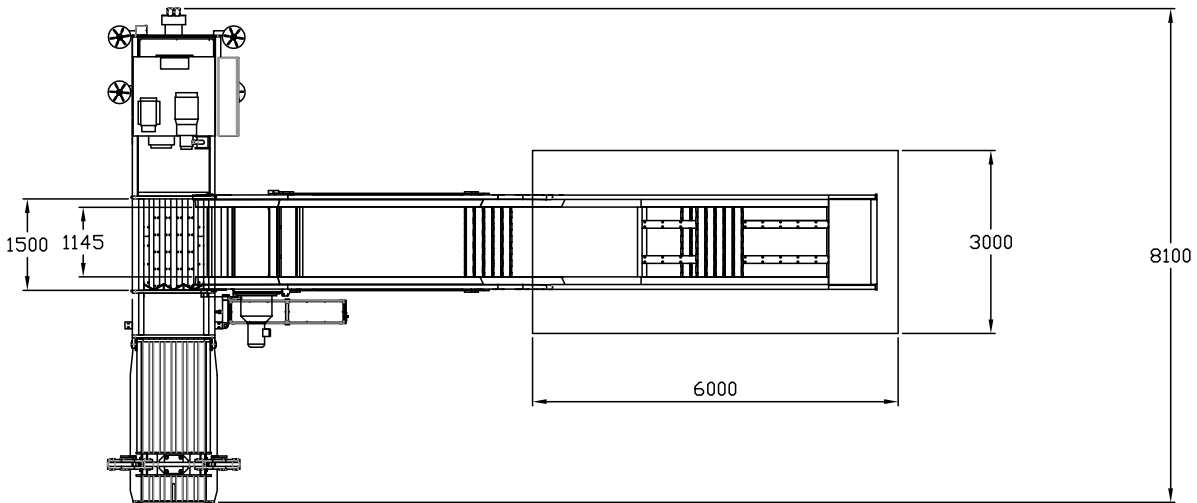

Size Comparison



Bale Weight
Up to 1500 Kg



Pressing Force
Up to 150 Ton



Motor
80/120/180HP



Waste Types
Cardboard, Paper,
Plastics, MSW

