



PROVEN PERFORMER

On-Premises Laundry

SWNMN2 (top loading washer),
SDEMNR (electric dryer), SDGMNR (gas dryer)

Top loading washer features

- Commercial all metal transmission offers highest quality and durability
- 2 Speed Motor
- Designed for durability and ease of use with simple push to start switch and reinforced control knobs
- Extra large capacity stainless steel tub keeps clothes looking their best
- Advanced suspension system eliminates the possibility of an unbalanced load



EASY OPERATION



STAINLESS STEEL WASHER DRUM

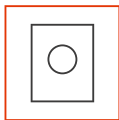

ROBUST DESIGN



LARGE DOOR OPENING



Controls

Top loading washer Push Button start

This control features a straightforward design that offers users simple water temperature and fabric selections.

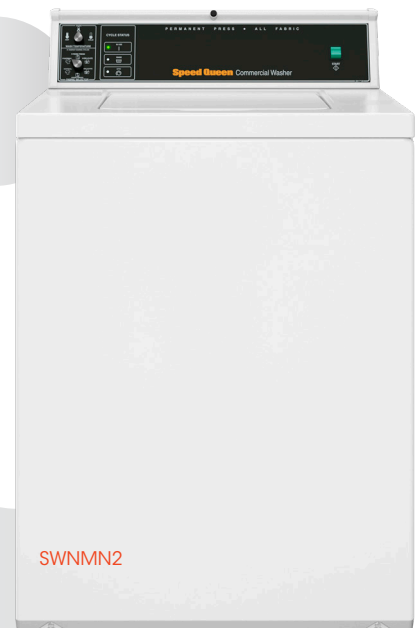

Dryer features

- Durable galvanized steel cylinder with an extra-large 198 litres of volume
- Efficient dryer heating with 27 MJ (gas models) and up to 4,000 Watts (electric models)
- Large, easy-to-clean lint compartment
- Reversible door
- 1913.8 sq. cm door opening is the largest in the industry, providing easy loading and unloading

Dryer Push Button control

This control features a straightforward design that offers users simple drying selections and uses cue lights to monitor progress through the drying cycle.

	SWNMN2	SDEMNR (Electric) SDGMNR (Gas)
Type	Top Loading Washer	Single Dryer
Control	Emech	Emech
Control location	Rear	Rear
Drum		
Capacity kg	8 kg	9 kg
Cylinder volume litres	92.3 Lt	198 Lt
Drum speed		
Spin speed G-Force	150	n/a
Spin speed rpm	710	n/a
Motor		
Motor size kW	0.37	0.25
Cabinet		
Cylinder finish	Stainless steel	Galvanized
Colours	White	White
Door type (solid/window)	n/a	Solid
Heating		
Heat sources	n/a	Electric or Natural Gas, LPG optional
Heating element (Electric W)	n/a	4000
Connection		
Gas inlet connection mm	n/a	9.5
Gas consumption MJ/Hr	n/a	27 MJ
Exhaust outlet dia. mm	n/a	102
Exhaust airflow litres/sec	n/a	85
Water temperatures	3	n/a
Operation		
Cycles	6	4
Water consumption per cycle litres	92.2	n/a
Water pressure kPa	140/830 kPa	n/a
Cycle indicator lights	Yes	Yes
Power		
Electrical requirements (voltage/Hz/Ph)	240/50/1, 6 amp	240/50/1, Electric 20 amp, Gas 4 amp
Transport data		
Net weight kg	82	Electric/Gas 59/61
Shipping weight kg	88	Electric/Gas 64/66
Dimensions H×W×D mm	1092×650×711	1092×683×711
Packing dimensions H×W×D mm	1124×699×762	1156×737×832
Agency approvals		
Available agency approvals	Electrical SAA	Electrical SAA, Gas AGA #4945



Dimensions

Top Loading Washer

	A	B	C	D	E	F	G	H	I	J
SWNMN2	651	775	730	1048	914	548	1026	1295	660	711

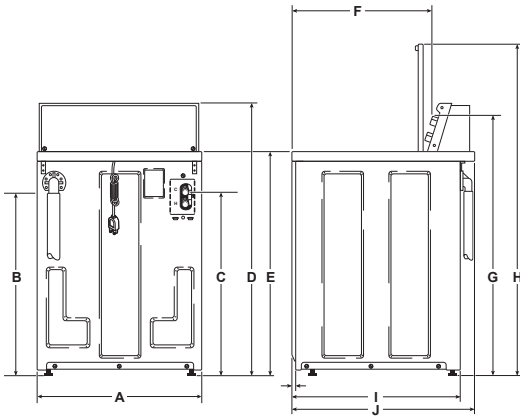

Electric Dryer

	A	B	C	D	E	F	G	H	I	J	K	L	M
SDEMNR	589	914*	1036*	1092*	391	392*	683	102	10	711	114*	203	597

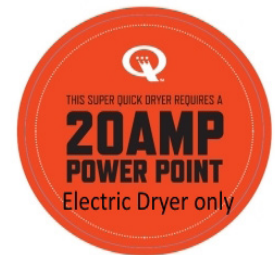
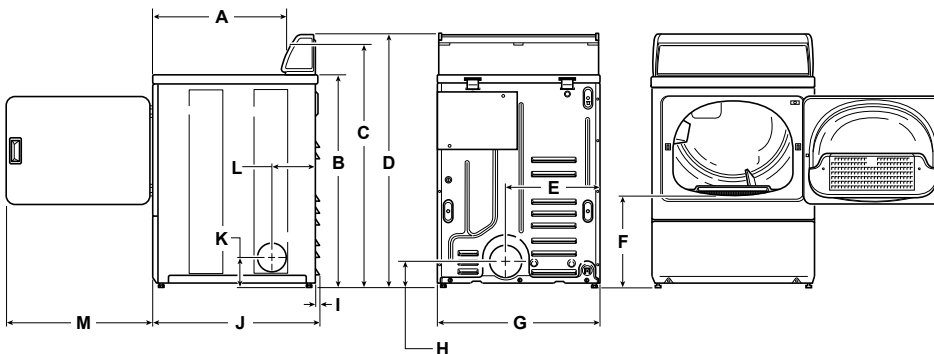

Gas Dryer

	A	B	C	D	E	F	G	H	I	J	K	L	M	N	O
SDGMNR	589	914*	1036*	1092*	391	392*	70*	60	683	102*	10	711	114*	203	597

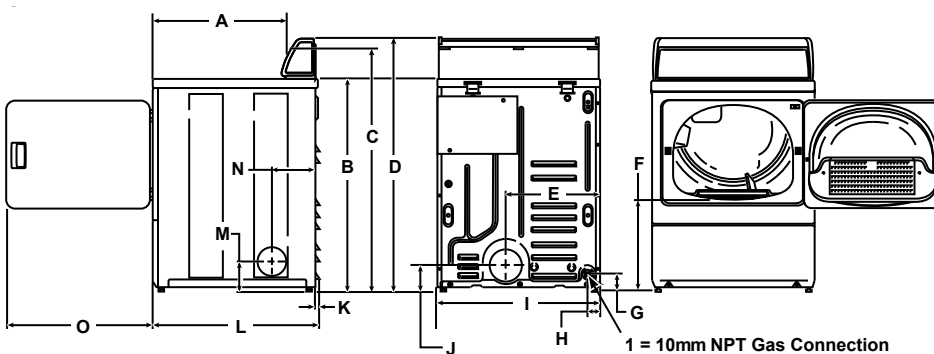

All measurements are in mm. *With levelling legs turned into base.

NOTE: Exhaust openings are 102 mm metal ducting.





Andrew Barton Laundry Systems.
67 Colebard Street West, Acacia Ridge,
QLD 4110
Ph: +61 7 3716 1333
Fax: +61 7 3716 1398
W: www.andrewbarton.com.au
E: info@andrewbarton.com.au
Servicing Queensland.

The content of this brochure (including, without limitation, any analysis forming part of it) is general information, for personal use only and should not be relied upon for investment purposes. This brochure provides information based on subjective assumptions and does not provide actual or expected returns, which may in practice be lower than those stated in the brochure. You should obtain independent financial advice prior to making any decision to invest in, or with, the distributors listed above. To the extent permitted by law, we do not accept any liability (whether in contract, tort, negligence or otherwise and howsoever arising), nor owe any duty of care to you, for any consequences of your acting (or refraining from acting) in reliance on the contents of this brochure. If you enter into a contract with us, we will require that you irrevocably waive your rights to bring a claim against us for acting in reliance on the content of this brochure. E&OE