

**Specification, Installation  
and Operation Manual**

**HOT FOOD SLIDES  
ANGLED SHELVES**

Models:

CH.HFSAG.2.750, CH.HFSAG.2.900, CH.HFSAG.2.1200 & CH.HFSAG.2.1500

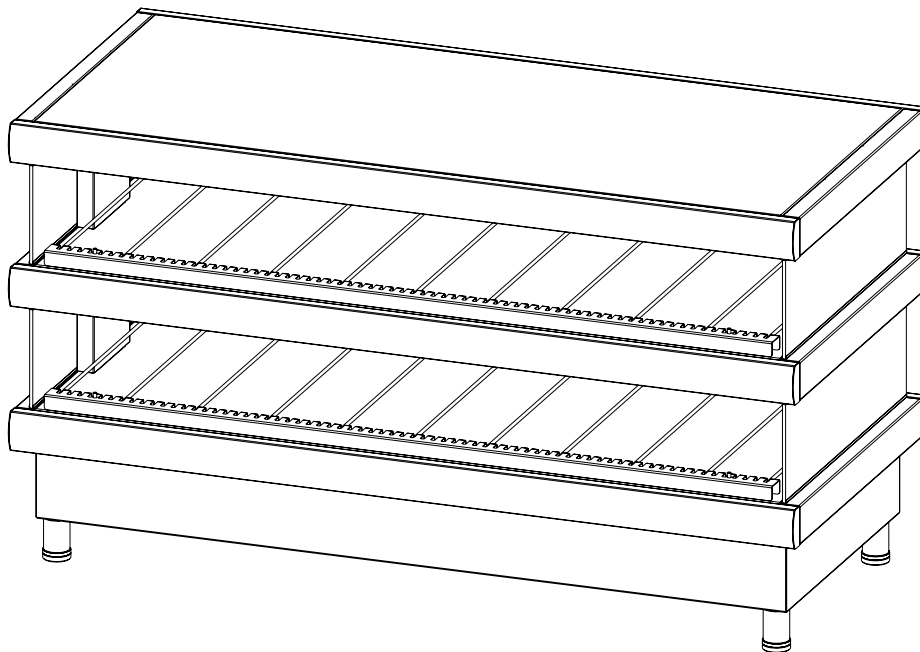

A guide on the use, care and maintenance  
of your quality Culinaire product



**Page Intentionally Left Blank**

## Introduction

Your New Culinaire Product. . . . .	3
Product Overview. . . . .	3
Attention . . . . .	4
General Information . . . . .	4
<i>Service</i>	

## Installation

Setting Up . . . . .	5
<i>Handling</i>	
<i>Unpacking</i>	
<i>Positioning</i>	
Hot Food Slide Dividers . . . . .	5
<i>Installing Dividers</i>	
Electrical Connection . . . . .	6
<i>Information</i>	

## Specification

Technical Specifications . . . . .	7
<i>Code Explanation</i>	
<i>CH.HFSAG.2.750</i>	
<i>CH.HFSAG.2.900</i>	
<i>CH.HFSAG.2.1200</i>	
<i>CH.HFSAG.2.1500</i>	

## Operation

Initial Start-up & Operation . . . . .	11
<i>Initial Start-up</i>	
<i>Operation</i>	
Temperature Adjustment . . . . .	11
GN Pans, Loading Hot Food Slides . . . . .	12
<i>Gastronorm Pans</i>	
<i>Loading Hot Food Slides</i>	
<i>Loading Restrictions</i>	
Food Safety. . . . .	12
<i>Food Temperature</i>	
<i>Food Storage</i>	
Cleaning . . . . .	13
<i>General Information</i>	
<i>Corrosion Protection</i>	
<i>Surface Finish</i>	
<i>Cleaning Schedule</i>	
<i>Materials Required</i>	
<i>Glass</i>	
Troubleshooting . . . . .	15
Replacing Heat Lamp Bulbs . . . . .	15

## Warranty

Appendix 1 – Australian Warranty and Contact Details . . . . .	16
Australian Warranty Policy & Procedure. . . . .	16
1. Commercial Warranty . . . . .	16
2. Consumer Warranty . . . . .	16
3. Warranty Clarification . . . . .	16
4. Warranty Claim Procedure . . . . .	17
5. Timing of Warranty Services . . . . .	17
6. General Maintenance and Repairs . . . . .	17
Warranty Request Form . . . . .	18

## Your New Culinaire Product

Thank you for choosing this quality Culinaire product. All our products are designed and made to meet the needs of food service professionals. By using, caring and maintaining your Culinaire product according to these instructions, your Culinaire product should give you many years of reliable service.

Stoddart is a wholly Australian owned company, which manufactures Culinaire commercial catering equipment. All Culinaire products are engineered and manufactured in Australia to provide excellent results whilst offering-value-for-money, ease-of-use and reliability.

Culinaire manufacture a comprehensive range of equipment for kitchens, food preparation and presentation.

## Product Overview

Configuration may vary according to model.

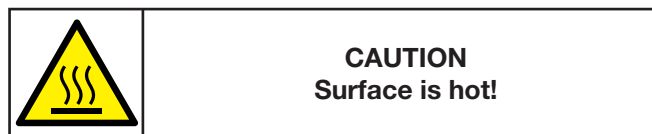

Code	Explanation
CH	= Culinaire Heated
HFSAG	= Hot Food Slide - Angled - Glass Sides
.2	= 2 Tier
xxxx	= 750 - 750mm wide unit
	= 900 - 900mm wide unit
	= 1200 - 1200mm wide unit
	= 1500 - 1500mm wide unit

### Hot Food Slides - CH.HFSAG.2.1500

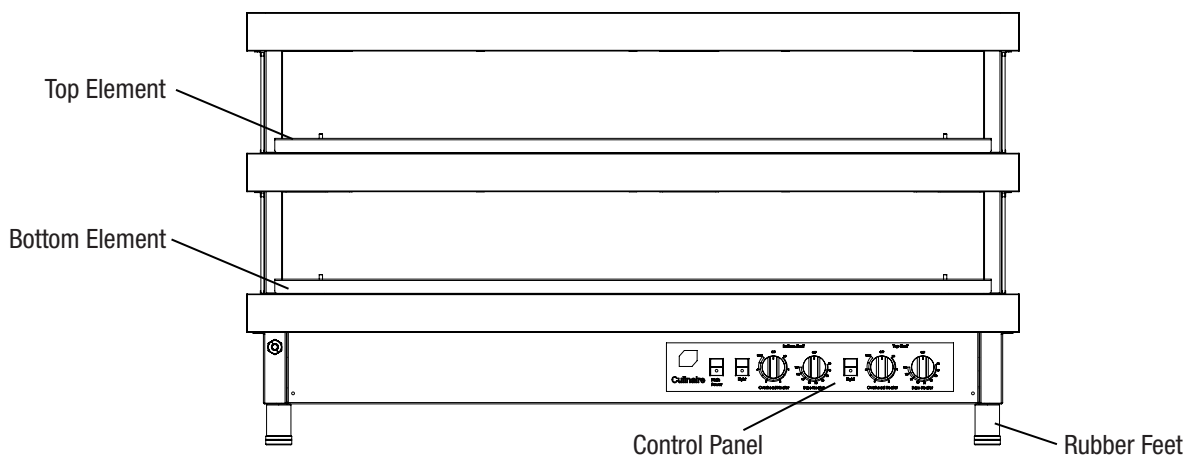

## Attention

Carefully read this instruction booklet, as it contains important advice for safe installation, operation and maintenance. Keep this booklet on hand in a safe place for future reference by other operators or users.

### Disclaimer

The manufacturer and distributor cannot be held responsible or liable for any injuries or damages of any kind occurred to persons, units or others, due to abuse and misuse of this unit in regards to installation, un-installation, operation, servicing or maintenance, or lack of conformity with the instructions indicated in this documentation.

All units made by the manufacturer are delivered assembled, where possible, and ready to install. Any installation, un-installation, servicing, maintenance and access or removal of any parts, panels or safety barriers that is not permitted, does not comply in accordance to this documentation, or not performed by a TRAINED AND AUTHORISED SPECIALIST will result in the IMMEDIATE LOSS OF THE WARRANTY.

The manufacturer cannot be held responsible or liable for any unauthorized modifications or repairs. All modifications or repairs must be approved by the manufacturer in writing before initiating. All modifications or repairs performed to this unit must be performed at all times by a TRAINED AND AUTHORISED SPECIALIST.ANTY.

**Stoddart design, manufacture & distribute Food Service Equipment (appliances) exclusively for the commercial market. This appliance is not designed nor intended for household or domestic use & must not be used for this purpose.**

This product is intended for commercial use, and in line with Australian electrical safety standards the following warnings are provided:

- This product is not intended for use by persons (including children) with reduced physical, sensory or mental capabilities, or lack of experience and knowledge, unless they have been given supervision or instruction concerning the use of the product by a person responsible for their safety. Children should be supervised to ensure that they do not play with the product
- If the supply cord is damaged, it must be replaced by the manufacturer, its service agent or similarly qualified persons in order to avoid a hazard

## General Information

When using any electrical unit, safety precautions must always be observed.

Our units have been designed for high performance. Therefore, the unit must be used exclusively for the purpose for which it has been designed.

Read these instructions carefully and retain for future reference.

- All units MUST be installed according to the procedures stated in the installation section of this manual
- In the case of new personnel, training is to be provided before operating the equipment
- DO NOT use this unit for any other purpose than its intended use
- DO NOT store explosive substances such as aerosol cans with a flammable propellant in or near this unit
- Keep fingers out of "pinch point" areas
- This unit is NOT waterproof. DO NOT use jet sprays or hoses to the exterior of the unit
- Only use this unit with voltage specified on the rating label
- Do NOT remove any cover panels that may be on the unit
- DO NOT use sharp objects to activate controls
- If any fault is detected, refer to troubleshooting
- The manufacturer declines any liability for damages to persons and/or things due and to an improper/wrong and/or unreasonable use of the machine

## Service

- Only specifically trained/qualified Technicians (Stoddart, one of our service agents, or a similarly qualified persons) should carry out any and all repairs, maintenance and services

## Setting Up

Improper installation, adjustments, alterations, service or maintenance can cause property damage, injury or death.

### Handling

- Use suitable means to move the unit: eg. A lift truck or fork pallet trucks (the forks should reach more completely beneath the unit)

### Unpacking

- Check the unit for damage before and after unpacking. If unit is damaged, contact the distributor and manufacturer
- Should any item have physical damage, report the details to the freight company and to the agent responsible for the dispatch within seven (7) days of receipt. No claims will be accepted or processed after this period
- The unit is supplied fully assembled
- Remove all protective plastic film, tapes, ties and packers before installing and operating
- Clean off any remaining residue from the interior/exterior of the unit using a clean cloth dampened with warm soapy water

### Positioning

- Choose an area that is well ventilated and provides access for future maintenance
- Place the unit on a level stable work surface capable of supporting its weight
- Do not position the unit in a wet area, an area with a lot of heat and steam or near flammable substances
- Allow an air gap between the unit and other objects or surfaces. We recommend a minimum gap of 100mm for normal operational use (if the unit is near any heat sensitive material we suggest you allow additional space)
- Please consult national and local standards to ensure that your unit is positioned in accordance with any existing requirement

## Hot Food Slide Dividers

### Installing Dividers

1. The dividers are provided with the unit.
2. The dividers slide into the slots provided. Ensure the dividers are placed in before use.

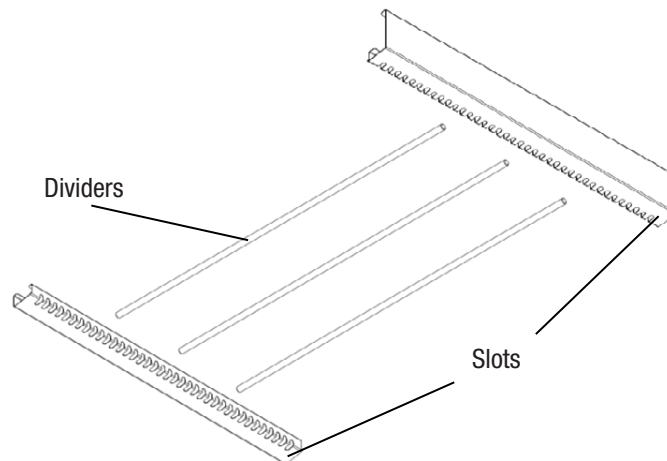

## Electrical Connection



**WARNING!**  
This unit must be installed in accordance with local electrical standards.

### Information

Aggregate electrical ratings of the Unit are expressed in kilowatts in this manual.

#### Single Phase Units:

A terminal block for on-site connection, by a licensed electrician will be supplied inside the service compartment of the unit and be indicated as:

- 1Ø + N + E

#### Plug and lead Connection:

- Plug the unit into the applicable power point

#### On-site Connection:

- The electrical supply must comply with the rating plate data
- Ensure that the machine is connected to a suitably rated and earthed power source
- Ensure that there is an isolation switch installed near the unit
- To connect the power, the unit has a terminal block in the electrical junction box. The power switches and electronic controller are the face of the electrical junction box
- The equipment should be earthed according to local electrical codes to prevent the possibility of electrical shock. It requires an earthed receptacle with separate electrical lines, protected by fuses or a circuit breaker of the proper rating
- If the supply cord is damaged, it must be replaced by the manufacturer, its service agent or similarly qualified persons in order to avoid a hazard. Please contact Stoddart for parts and we will advise how to do this in order to avoid any electrical hazard
- The power cable should be dry and/or isolated from moisture or water



**WARNING!**  
Some procedures in this manual require the power to the equipment to be turned off and isolated. Turn the power OFF at the power point and unplug the power supply lead by the plug body. If the power point is not readily accessible turn the equipment off at the isolation switch or the circuit breaker in the switchboard. Attach a yellow "CAUTION-DO NOT OPERATE" tag. This must be performed where relevant unless the procedures specify otherwise.  
**FAILURE TO DO SO MAY RESULT IN ELECTRIC SHOCK.**

**Technical Specifications**
**Code Explanation**

Code	Explanation
CH	= Culinaire Heated
HFSAG	= Hot Food Slide - Angled - Glass Sides
.2	= 2 Tier
xxxx	= 750 - 750mm wide unit
	= 900 - 900mm wide unit
	= 1200 - 1200mm wide unit
	= 1500 - 1500mm wide unit

**CH.HFSAG.2.750**

SPECIFICATIONS	
Model	CH.HFSAG.2.750
Width	750mm
Depth	680mm
Height	781mm
Voltage	220-240V, 50Hz
Power (kW)	1.88kW
Connection	1 Phase, Neutral, Earth
Temperature Range	65-90°C

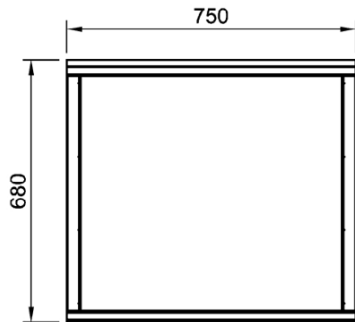
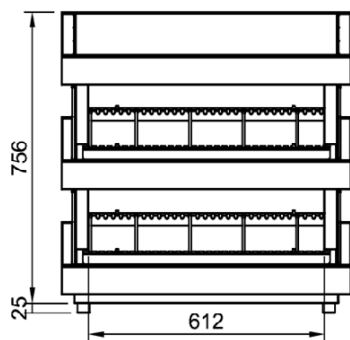
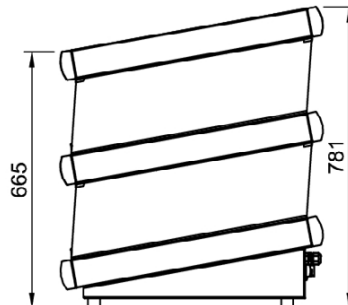
**Plan View**

**Front Elevation**

**End Elevation**

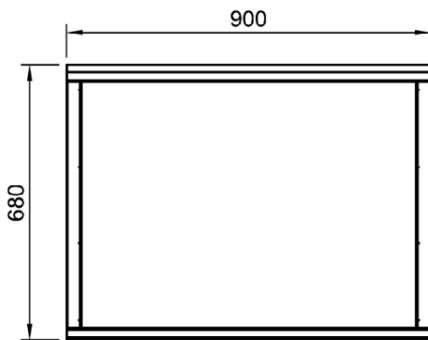

**CH.HFSAG.2.900**

SPECIFICATIONS	
Model	CH.HFSAG.2.900
Width	900mm
Depth	680mm
Height	781mm
Voltage	220-240V, 50Hz
Power (kW)	2.22kW
Connection	1 Phase, Neutral, Earth
Temperature Range	65-90°C



Plan View

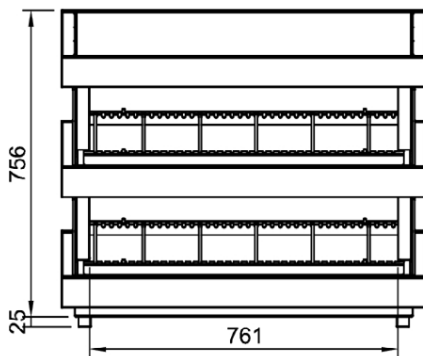

Front Elevation

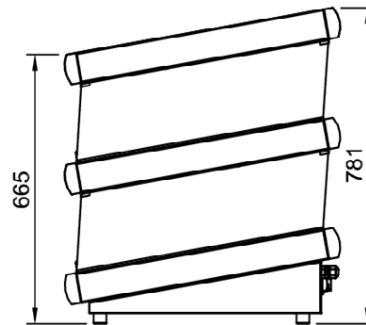

End Elevation

**CH.HFSAG.2.1200**

SPECIFICATIONS	
Model	CH.HFSAG.2.1200
Width	1200mm
Depth	680mm
Height	781mm
Voltage	220-240V, 50Hz
Power (kW)	3.4kW
Connection	1 Phase, Neutral, Earth
Temperature Range	65-90°C

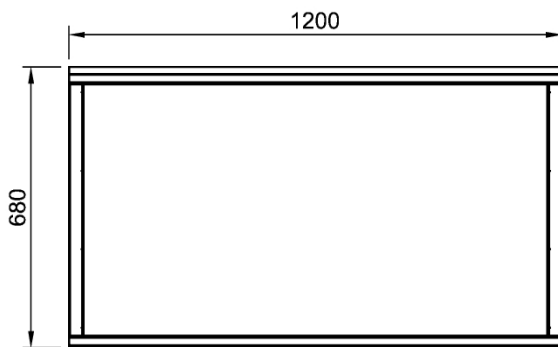
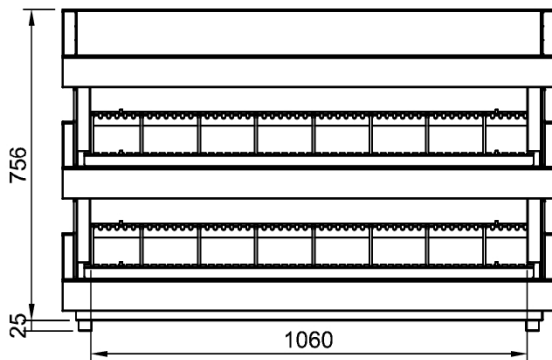
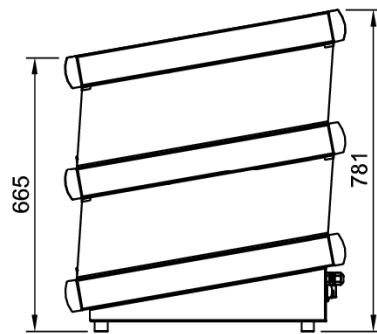

**Plan View**

**Front Elevation**

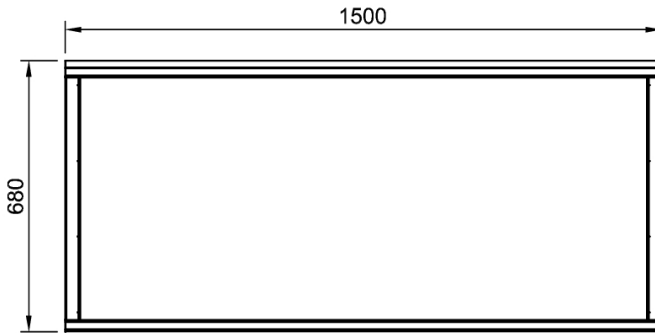
**End Elevation**

**CH.HFSAG.2.1500**

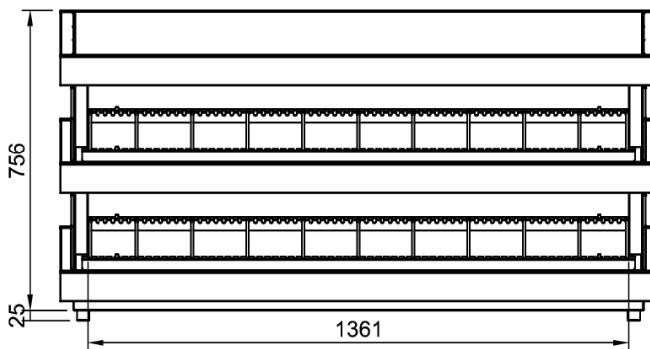
SPECIFICATIONS	
Model	CH.HFSAG.2.1500
Width	1500mm
Depth	680mm
Height	781mm
Voltage	220-240V, 50Hz
Power (kW)	3.49kW
Connection	1 Phase, Neutral, Earth
Temperature Range	65-90°C



Plan View



Front Elevation

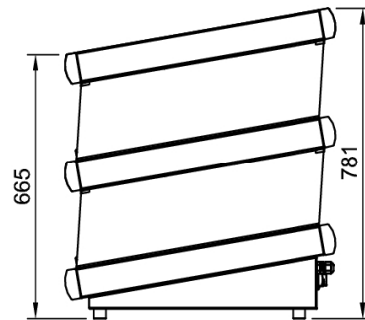

End Elevation

## Initial Start-up & Operation

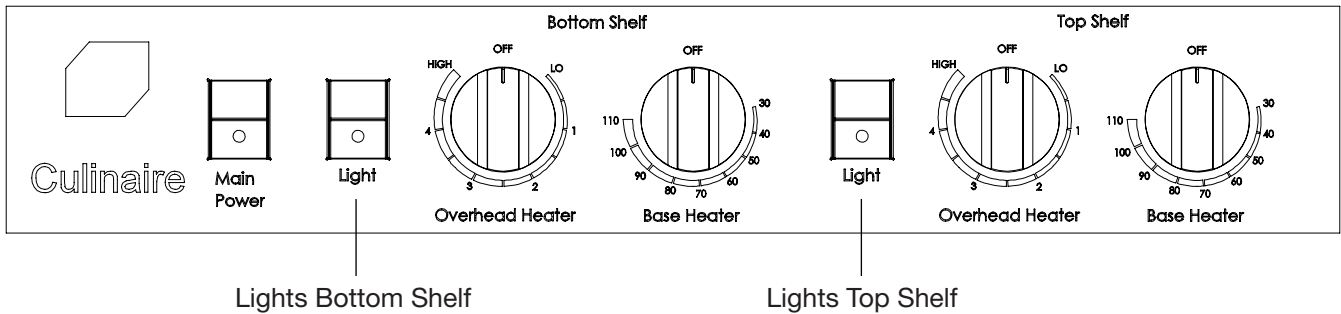

### Initial Start-up

- Before switching ON the unit, ensure the unit is installed correctly.
- Switch the power ON and check that the switches and knobs switch ON the lights and heaters.
- Leave unit for 1 - 2 hours to remove any fumes or odours.
- Switch the unit OFF and allow the unit to cool. After, clean the whole unit.
- Your unit is now ready to operate.

### Operation

- The unit can be switched ON or OFF with the MAIN POWER button on the front of the unit.
- The POWER button is a protection switch. No other switch can operate if the POWER button is OFF.
- Lights can be switched ON or OFF with the LIGHT button on the front of the unit.

	<p><b>WARNING!</b></p> <p>Take extreme care when removing the tray, skin burns to you or other persons can occur from the hot water or the hot tray. PROTECTIVE GEAR must be worn</p>
---	---

### Temperature Adjustment

- A simmerstat controls the heat to the OVERHEAD elements and can be set between LO and HI. Twist the knob around reaching the desired element temperature.
- A thermostat controls the temperature to the BASE and can be set between 30°C to 110°C. Twist the knob around reaching the desired temperature.
- The temperature probe only measures the temperature of the water/air, NOT the food temperature

## GN Pans, Loading Hot Food Slides

### **Gastronorm Pans**

- All Gastronorm pans and extra dividers are sold separately
- Each module can hold one 1/1 pan, two 1/2 pans, three 1/3 pans, four 1/4 pans, six 1/6 pans and nine 1/9 pans. Pan depths are 25mm, 65mm, 100mm and 150mm. Contact your distributor about the best possible depth for the product you intent to display
- For 1/6 and 1/9 Gastronorm pans, extra dividers are required

### **Loading Hot Food Slides**

- Ensure that the unit is switched ON and have reached operating temperature before placing any food in the unit
- All food placed in the well **MUST** be pre-heated/cooked
- Ensure unit is clean before placing food inside
- 1/1 or one 2/1 gastronorm pans can be placed per shelf no wire shelves are needed
- Take caution when opening the cabinet as hot steam can rise from the food. Pull the gastronorm pans and shelves out slowly as hot liquid can spill and burn
- When loading, load the lower section of the cart first and work your way up to the top of the cart. Do the reverse to unload
- Food should be left in the unit no longer than 1 hour

### **Loading Restrictions**

- Ensure the heat vents are **NOT** covered when serving items and gastronorm pans are in the unit. Airflow restrictions will change the temperature within the cupboard.
- Overloading the shelves can bend and damage the shelves and shelf clips.

## Food Safety

### **Food Temperature**

- All food **MUST** be pre-heated/cooked before placing in the unit. Attempting to cook food with this unit can lead to food poisoning
- Ensure the well is maintaining the food temperature over 65°C
- The temperature reached on the temperature gauge is the water/air temperature, **NOT** the food temperature
- It is important to regularly monitor the food temperature in the Bain Marie or the Hot Cupboard



**Important!**  
**This unit is not designed to cook products, it only maintains them above the regulated 65°C serving temperature.**

### **Food Storage**

- All storage of food should comply with local health standards and regulations
- All pans should be cleaned and placed in night storage. No pans should be left in the unit
- This unit is **NOT** designed to store product after hours. The unit **MUST** be switched OFF
- If the unit is moved for night storage, ensure the castors are locked (island buffet/mobile units only)

## Cleaning

### General Information



- Cleaning is recommended for health and safety purposes and to prolong the life of the unit
- Do NOT use abrasive pads or cleaners on the stainless steel or any other metal parts of the unit
- Do NOT use industrial chemical cleaners, caustic based cleaners or bleaches and bleaching agents, many will damage the metals and plastics used on this unit
- When drying, metal surfaces should be wiped with a soft cloth in the same direction as grained polish
- Do NOT remove any screws for cleaning. All internal sections of the unit are to be cleaned by a qualified technician
- This unit is NOT waterproof, do NOT hose, do NOT pour water directly onto the unit

### Corrosion Protection

- Stainless steel exhibits good resistance to corrosion however, if not properly maintained stainless steel can rust and/or corrode
- Any sign of mild rust and/or corrosion should be thoroughly cleaned with warm soapy water and dried as soon as possible
- NEVER use abrasive pads or cleaners for cleaning
- All metal surfaces should be checked while cleaning for damage, scuffs or scrapes as these can lead to rust and further damage to the product
- Mild rust and/or corrosion can be treated with a commercial cleaning agent that contains citric/oxalic/nitric/phosphoric. Do NOT use cleaning agents with chlorides or other harsh chemicals as this can cause corrosion. After treatment, wash with warm (not hot) soapy water and dry thoroughly
- Thoroughly wipe the surfaces dry after cleaning and do NOT let water pool on the unit. Check crevices and folds for pooling
- If an abrasive product is used while cleaning, thoroughly dry the unit and leave in an open or oxidised area for the stainless steel protective layer to replenish
- When using, ensure all liquids and moisture is cleaned up straight away. Food liquids such as juices from vegetables and fruits should NOT be left on preparation surfaces
- Do NOT leave items on the stainless steel such as cutting boards, rubber mats and bottles

### Surface Finish

- To protect the polish, stainless steel should be dried by wiping a dry soft cloth in the same direction as grained polish
- For NON-food contact surfaces, a light oil can be wiped on the surfaces with a cloth to enhance the stainless steel surface. Wipe in the direction of the grain
- Some commercial stainless stain cleaners can leave residue or film on the metal; this may trap fine particles of food on the surface, thus deeming the surfaces not food safe

	<p style="text-align: center;"><b>WARNING!</b> This unit is NOT waterproof, do NOT hose. DO NOT pour water directly onto the unit.</p>
	<p style="text-align: center;"><b>Important!</b> Some commercial stainless stain cleaners leave residue or film on the metal that may entrap fine particles of food, thus deeming the surface not FOOD SAFE.</p>
	<p style="text-align: center;"><b>WARNING!</b> Wait until the unit has cooled to a safe temperature before undertaking any cleaning or maintenance. Contact with hot surfaces can cause burns and serious injury.</p>

### ***Cleaning Schedule***

- Daily cleaning is required for the Banquet Cars, Warming Drawers and external surfaces. This will help to maintain and prolong the efficiency of your unit
- The unit should be cleaned at the end of each work day

### ***Materials Required***

- Stainless Cleaner
- Non Abrasive Cleaning pad
- Clean Sanitised Cloth
- Paper Towel
- Container of warm water
- Appropriate PPE (Personal Protective Equipment)

### ***Glass***

- Clean the glass with a glass cleaner or warm (not hot) soapy water, and a sponge
- Wiping dry with a squeegee is best

**Troubleshooting**

	<b>WARNING!</b> <b>Technician tasks are only to be completed by qualified service people. Check faults before calling service technician.</b>
---	--

(O) = Operator  
(T) = Technician Task

Problem	Possible Causes	Task	Remedy
Unit does not operate / start	The mains isolating switch on the wall, circuit breaker or fuses are OFF at the power board	O	Turn isolating switch, circuit breaker or fuses ON
	The power switch of the unit is OFF	O	Turn the power switch ON
	Electrical wiring damaged	T	Replace / Fix electrical wiring
Unit not heating	Temperature not set to the right setting	O	Check setting and adjust the temperature
	Exhaust fan above the unit	O	Move unit / exhaust fan
	Temperature probe broke	T	Replace probe
	Element/s blown	T	Replace element/s
Food not at desired temperature	Thermostat set incorrectly	O	Adjust thermostat
	Unit is not reaching required temperature	O/T	See above
	Heat lamps not switched ON	O	Switch ON
Heat lamps not working	The lamp switch is OFF	O	Turn lamp switch ON
	Bulb is blown	T	Replace bulb
Unable to adjust temperature	Element / thermostat failure	T	Test and replace the element or thermostat if necessary

**Replacing Heat Lamp Bulbs**

- Bulbs should be allowed to cool for 10 - 15 minutes before removing
  - All heat lamp fitting are spring loaded for easy replacement
  - Heat lamp bulbs should only be replaced with gloves or a soft cloth. No skin should touch the new bulb. If skin touches the new bulb, wipe the bulb with a soft cloth and rubbing alcohol to remove all possible oils
1. Isolate from the power supply
  2. Take off the end capping by removing the retaining screw (do not discard)
  3. Slide out the four lamp shield bars
  4. Holding the old bulb with a soft cloth or glove, press into one of the sockets, rotate out and remove
  5. Holding the new bulb with a soft cloth or glove, press into one of the sockets, rotate in and slowly release the bulb into the other socket, ensuring that the bulb does NOT become broken
  6. Re-install the lamp shield bars then place the end capping into position and secure with the retaining screw

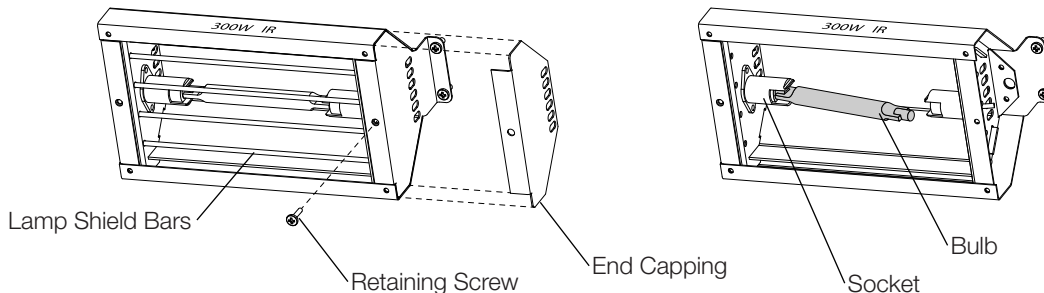



## Appendix 1 – Australian Warranty and Contact Details

As the exclusive manufacturer and distributor of Stoddart products in Australia, Stoddart would like to congratulate you on your purchase of a Stoddart product.

Stoddart design, manufacture & distribute Food Service Equipment (appliances) exclusively for the commercial market.

These appliances are not designed nor intended for household or domestic use & must not be used for this purpose.

This product is intended for commercial use, and in line with Australian electrical safety standards the following warnings are provided:

- This appliance is not intended for use by persons (including children) with reduced physical, sensory or mental capabilities, or lack of experience and knowledge, unless they have been given supervision or instruction concerning the use of the product by a person responsible for their safety. Children should be supervised to ensure that they do not play with the product.
- If the supply cord is damaged, it must be replaced by the manufacturer, its service agent or similarly qualified persons in order to avoid a hazard. Please contact Stoddart for parts and we will advise how to do this in order to avoid any electrical hazard.

## Australian Warranty Policy & Procedure

Stoddart is committed to providing a comprehensive and fair warranty for all of its equipment. The warranty incorporates a commercial manufacturers' warranty, together with the consumer warranty provisions of the National Consumer Protection Act (2009).

### 1. Commercial Warranty

- 1.1 Stoddart warrants to the original purchaser ("**Customer**") of equipment manufactured or distributed by Stoddart that for **12 months** from the date of installation of the equipment by Customer (the "**Warranty Period**"), any defect in workmanship or material will, subject to clauses 1.2 and 3, be:
  - a) Repaired without charge; or
  - b) In respect of any **Major Failure** which cannot be repaired, replaced or the purchase money refunded.
- 1.2 Stoddart will not be liable for any associated loss, damage or compensation claim resulting from any defect in workmanship or material, and such liability is expressly excluded from the operation of clause 1.1.

### 2. Consumer Warranty

- 2.1 Subject to clause 3, equipment supplied by Stoddart to Customer comes with guarantees that cannot be excluded under the Australian Consumer Law. Customer is entitled to a replacement or refund for a **Major Failure** and compensation for any other reasonably foreseeable loss or damage. Customer is entitled to have the equipment repaired, or replaced if the equipment fails to be of an **Acceptable Quality** and that failure does not amount to a Major Failure.

### 3. Warranty Clarification

- 3.1 Customer acknowledges and agrees:
  - i. A **Major Failure** occurs when the equipment suffers repeated and/or unexpected failure that cannot be repaired to Stoddart's satisfaction (acting reasonably) or which Stoddart considers (acting reasonably) renders the equipment unsafe or inoperable;
  - ii. Stoddart can only warrant the equipment will be of an **Acceptable Quality** when Customer uses the equipment in accordance with Stoddart's manufacturer's instructions or user manual ("**Instructions**"). Acceptable Quality does not imply a lifetime guarantee for the equipment;
  - iii. Certain components have a finite expected life, especially in a commercial or high-use environment. For example components such as refrigeration compressors, elements, thermostats/simmerstats, switches, fans, and temperature controllers can be expected to last up to **12 months** when used in accordance with the instructions;
  - iv. In a commercial environment, components such as lamps, fluorescent tubes, light bulbs, glass, silicone seals, gaskets and plastic components will require regular replacement. This is not covered by warranty and is at Customer's cost.;
  - v. The life of equipment may be adversely affected by misuse, neglect, unauthorised alteration, incorrect installation, power surges, accident, use of inappropriate chemicals, flooding, and acts of God;
  - vi. Proper maintenance and cleaning of equipment in accordance with the Instructions is essential to the equipment's effective operation;
  - vii. On site warranty services are limited to sites within 50km from the nearest Stoddart authorised service agent and service agent's reasonable travel costs must be paid by Customer prior to the commencement of the repairs;
  - viii. Additional labour costs will apply for service outside standard business hours of 8.00am to 4:30pm, Monday to Friday and on public holidays;
  - ix. Stoddart cannot guarantee the performance of equipment made specifically to Customer's design or specifications. Stoddart will, where reasonably possible, draw any issues arising from Customer's design or specifications to Customer's attention during the commissioning and/or manufacturing process; and
  - x. Customer must pay additional costs incurred by Stoddart as a result of Customer failing to provide suitable access to the equipment for inspection and service.

3.2 Stoddart's warranty liability under clauses 1 and 2 of these Terms exclude or do not cover:

- a) The matters acknowledged by Customer in clause 3.1;
- b) Situations where Stoddart is not satisfied (acting reasonably) the equipment or any part of the equipment has been used in accordance with the Instructions including misuse, neglect, unauthorised alteration, incorrect installation, power surges, accident, use of inappropriate chemicals, flooding, fire or act of God;
- c) Any consequential loss, damage or expense arising directly or indirectly from use of the equipment otherwise than in accordance with the Instructions;
- d) Any damage or malfunction arising from, or relating to, Customer's failure to properly maintain or clean the equipment in accordance with the Instructions;
- e) Damage caused to equipment during transportation, which is outside Stoddart's standard delivery conditions.
- f) Breakage or replacement of lamps, fluorescent tubes, light bulbs, glass, silicone seals, gaskets and plastic components.;
- g) Maintenance, repair or other works not undertaken by a Stoddart authorised service agent.
- h) Where remote refrigeration is connected by a person other than Stoddart to equipment produced by Stoddart, Stoddart cannot accept claims for repair of TX valves and control components, as the fault may arise from the installation of the remote refrigeration lines, equipment, and gas, by a party over which Stoddart has no control.
- i) Transportation costs associated with transporting the equipment to a Stoddart authorized service agent where Stoddart considers (acting reasonably) that repairs cannot be undertaken on-site; and
- j) Unless agreed to by Stoddart in writing to the contrary, warranty is not included in the sale price for goods sold to or installed in an overseas location.

## 4. Warranty Claim Procedure

4.1 The following procedure must be followed to claim under Stoddart's warranties:

- a) Refer to the trouble-shooting section of the Instructions to establish the nature of the fault. Check the equipment is plugged-in, turned-on or has no other valid reason for not operating.
- b) If step (a) does not overcome the issue, you should report the fault with the equipment to our service department (phone 1300 307 289 or fax 07 3344 6166). Our service department will assist you with further trouble-shooting. If our service department is unable to resolve the fault with the equipment they will request you complete a Stoddart Warranty Request Form and fax (07 3344 6166) or email (service@stoddart.com.au) it to us. This form can also be completed online ([www.stoddart.com.au/warranty-claim](http://www.stoddart.com.au/warranty-claim)).
- c) To complete a Stoddart Warranty Request Form you will require the following information:
  - I. Proof of purchase stating model number and date of purchase;
  - II. The serial number of the equipment (this is located on the ratings plate sticker);
  - III. A description of the fault/problem;
  - IV. Your company details including the exact location of the equipment; and
  - V. Any restrictions on times or methods of access to the equipment.

Stoddart will not arrange a warranty call out until it receives the above information from you in writing.

- d) Upon receipt of a properly completed Stoddart Warranty Request Form, Stoddart will check its records to confirm whether the equipment is eligible for warranty repair. If warranty repair is required, Stoddart will issue an OFFICIAL AUTHORISATION NUMBER and details of work to be carried out by a Stoddart authorised service agent. This authorisation number **MUST** be obtained before any work is carried out. Stoddart will not accept invoices for work carried out without an official authorisation number or by an unauthorised service agent.
- e) Customer must quote the official authorisation number on all correspondence and invoices relating to a warranty claim to ensure prompt processing by Stoddart.
- f) Customer must pay all costs associated with a call-out for work that is not related to warranty repairs or outside Stoddart's Terms immediately.

## 5. Timing of Warranty Services

5.1 Stoddart will comply with its warranty liabilities contained in these Terms in a timely manner.

## 6. General Maintenance and Repairs

6.1 The equipment must be repaired and maintained by a qualified technician. Stoddart's authorised service agents are experienced technicians who understand the equipment and carry commonly used spare parts. Contact Stoddart's national service number listed below for details of your nearest Stoddart authorised service agent.

**For Warranty, maintenance, spare parts and repairs, contact:  
Tel: 1300 307 289 Fax: 07 3344 1000 email: [service@stoddart.com.au](mailto:service@stoddart.com.au)**

## Warranty Request Form

This form can also be completed online at: [www.stoddart.com.au/warranty-claim](http://www.stoddart.com.au/warranty-claim).

### WARRANTY REQUEST FORM

Phone: (07) 3440 7600 Int: +617 3440 7600  
 Phone: 1300 307 289  
 Fax: (07) 3344 1000 Int: +617 3344 1000  
 Email: [service@stoddart.com.au](mailto:service@stoddart.com.au)



To ensure we can provide the best possible service we require you to complete this form. Make, model and serial number, along with other essential information. To secure a call, you must also have an account with Stoddart or complete the credit card details below.  
**THIS FORM MUST BE COMPLETED OR WARRANTY CANNOT BE PROCESSED**

Name of contact person on site: \_\_\_\_\_ Date: / /

Business/Organisation name: \_\_\_\_\_

Street Address: \_\_\_\_\_

Suburb: \_\_\_\_\_ State: \_\_\_\_\_ Post Code: \_\_\_\_\_

Phone (Site): \_\_\_\_\_ Mob: \_\_\_\_\_

Equipment Type: \_\_\_\_\_ Brand: \_\_\_\_\_

Model/PNC no.: \_\_\_\_\_ Serial no.: \_\_\_\_\_

Location (large sites only): \_\_\_\_\_ Open: \_\_\_\_\_ Close: \_\_\_\_\_

Date of purchase: / /

Company purchased from: \_\_\_\_\_

(please provide a copy of your tax invoice or delivery docket as proof of purchase)

Description of fault: \_\_\_\_\_

Has the following been checked (tick box if appropriate and checked)?

Electrical power supply  Gas  Water Supply

Name of person requesting warranty (please print): \_\_\_\_\_

**CREDIT CARD DETAILS - Required as security against chargeable work (see note below)**

Card type: Visa  Mastercard

Cardholder name: \_\_\_\_\_ Card no.: \_\_\_\_\_

Signature: \_\_\_\_\_ Expiry Date: / /

PLEASE NOTE: Warranty call-outs take place Mondays to Fridays between 8.00 and 16.30 (except public holidays). Any calls outside these times will be subject to penalty rates. Certain items such as glass components and light fittings are not covered under warranty. Claims for non-covered parts, no faults found, travel over 50km or other items outside our standard terms and conditions will be chargeable. Any chargeable items will be COD terms – payable onsite.

**CREDIT CARD INFORMATION MUST BE PROVIDED AS SECURITY AGAINST FALSE WARRANTY CALL-OUTS.  
 FAILURE TO DO SO WILL RESULT IN REQUEST BEING UNATTENDED.  
 NORMAL BUSINESS HOURS ARE 8AM – 4.30PM MONDAY TO FRIDAY**



***Stoddart Sales  
Servicing and Replacement***

**Sales Department**

Tel: 1300 791 954

Fax: (07) 3344 1000

Email: [fseorders@stoddart.com.au](mailto:fseorders@stoddart.com.au)

**Service & Spares Department**

Tel: 1300 307 289

Email: [service@stoddart.com.au](mailto:service@stoddart.com.au)

Email: [spares@stoddart.com.au](mailto:spares@stoddart.com.au)