



Almega Friendly series II
Arc Welding Robot
NEW *FD-B6L*

Fast, Slim, User-Friendly

Improved all performances!
New robot with built-in cables



Best for large structures
by its long arm
All cables required for
synchro-feed welding are already
built into the robot



Improved all performances! New robot with built-in cables

Fast

Industry leading level speed.
Reduce cycle time

User friendly

All cables required for
synchro-feed welding are
already built into the robot

Slim

30% reduce in foot print
High-density layout

Powerful

Max. Payload 6kg
Allows to be equipped with various
torches and sensors

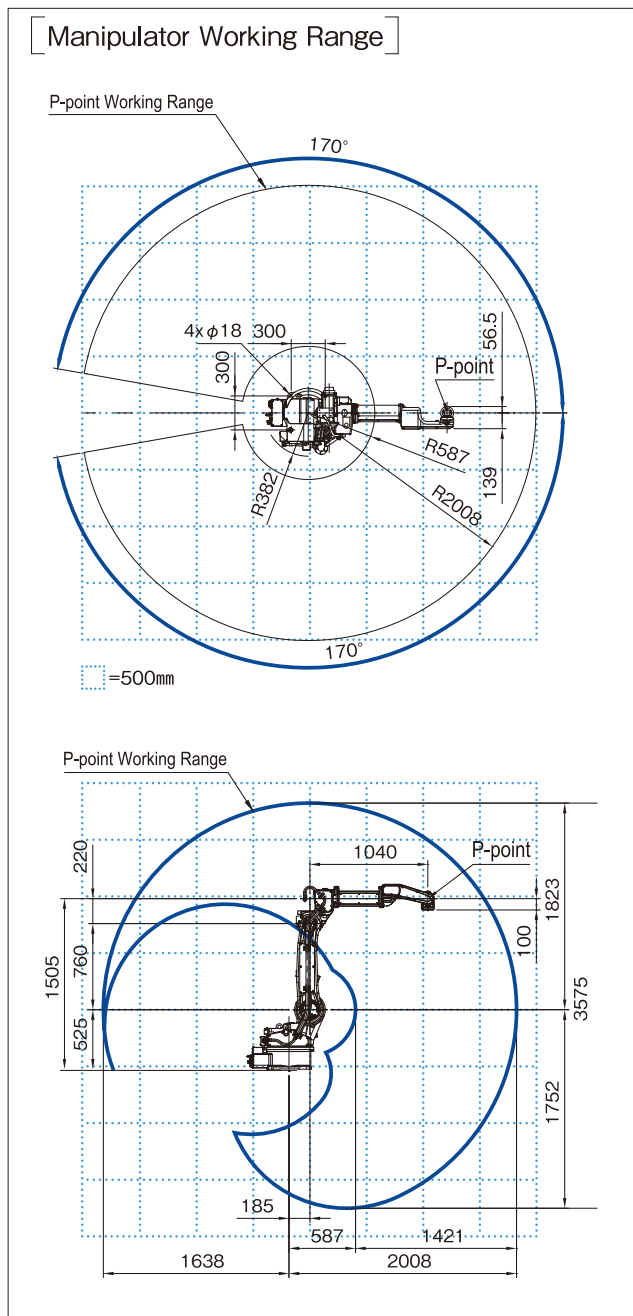

[Manipulator Specifications]

| | | Specification | | |
|-----------------------------------|-----------------------------|---|--|-----------------------|
| Name | | FD-B6L | | |
| Structure | | Vertically articulated type | | |
| Number of Axes | | 6 | | |
| Wrist Capacity | | 6 kg | | |
| Positional Repeatability (Note 1) | | ±0.05mm (Note 1) | | |
| Driving Method | | AC servo motor | | |
| Driving Capacity | | 4632W | | |
| Positional Feedback | | Absolute encoder | | |
| Working Range | Arm | J1 (Rotation) | ±170°(±50°) (Note 2) | |
| | | J2 (Front/back) | -155°~+100°(Note 3) | |
| | | J3 (Up/down) | -170°~+190° | |
| Working Range | Wrist | J4 (Swing) | ±155°(±170°) (Note 4) | |
| | | J5 (Bending) | -45°~+225° (Note 5) | |
| | | J6 (Twist) | ±205°(±360°)(Note 4,5) | |
| Maximum Speed | Arm | J1 (Rotation) | 3.93rad/s {225°/s} (3.05 rad/s {175°/s}) (Note 2) | |
| | | J2 (Front/back) | 3.58rad/s {205°/s} | |
| | | J3 (Up/down) | 3.84rad/s {220°/s} | |
| | Working Range | Wrist | J4 (Swing) | 7.50rad/s {430°/s} |
| | | | J5 (Bending) | 7.50rad/s {430°/s} |
| | | | J6 (Twist) | 11.00rad/s {630°/s} |
| Wrist Allowable Load | Allowable Moment | J4 (Swing) | 10.5N·m | |
| | | J5 (Bending) | 10.5N·m | |
| | | J6 (Twist) | 5.9N·m | |
| | Allowable Moment of Inertia | Wrist | J4 (Swing) | 0.28kg·m ² |
| | | | J5 (Bending) | 0.28kg·m ² |
| | | | J6 (Twist) | 0.06kg·m ² |
| Arm Cross-sectional Area | | 6.37m ² ×340° | | |
| Environmental Conditions | | Temp: 0~45°C, Hmd: 20~80%RH (No Condensation) | | |
| Mass (weight) | | 237 kg | | |
| Capacity of Upper Arm | | 20kg (Note 6) | | |
| Installation Method | | Floor-/Ceiling-/Wall-mounted | | |
| Paint Color | | White (Munsell notation 10GY 9/1) | | |

(Note 1) Positional repeatability of the tool center point (TCP) value complies with the JIS -B-8432 Standard.
 (Note 2) Specifications for wall mounting appear in parentheses.
 (Note 3) The working range of the J2 axis may be restricted when wall-mounted.
 (Note 4) This specification applies when a single-wire power cable is fed through the hollow part of J4 and J6.
 The value in parentheses represents all other specifications.
 (Note 5) Working range of J6 axis may be restricted by the position of J5 axis.
 (Note 6) The capacity of the upper arm varies with the wrist capacity.



DAIHEN Corporation

4-1, Koyocho-nishi, Higashinada-ku, Kobe, Hyogo 658-0033, Japan
 Phone: (Country Code 81) 78-275-2006
 Fax: (Country Code 81) 78-845-8159

Note | This product and the technologies (including software) used in the product are subject to Catch-All Controls. When exporting any of them, verify the users, applications, etc. according to the applicable laws and regulations and take appropriate procedures such as applications for export permission to the Minister of Economy, Trade and Industry if required.

●The information contained in this catalog is current as of April 2021 and is subject to revision without notice.

Daihen Robot Site
www.daihen-robot.com/en/