

# **SHELTER ASSEMBLY** **MANUAL**

**Back Wall for  
20ftx20ft & 20ftx40ft**

## Parts List

Code	Description	Qty
	Base plates at side of back	
2	wall Base plates at middle of back wall	2 sets
2B	Side standing legs Upper side standing legs	2 sets
5	Lower standing legs at middle of back wall	2
6	Middle standing legs at middle of back	2
15	wall Upper standing legs at middle of back	2
16	wall Horizontal tubes Bottom tensioning	2
16A	tubes Back cover Expansion screw	2
17	Welding iron plate Clips Rope Carriage	3
18	bolts M8*80	3
20		1
21		8
22		4
22A		4
23		1 bundle
26		32 sets
28	Bolts M10*30	4 sets
30	Added standing legs to suit HQ container	4
32	End cap for bottom tensioning tubes	6

A---Back wall assembly

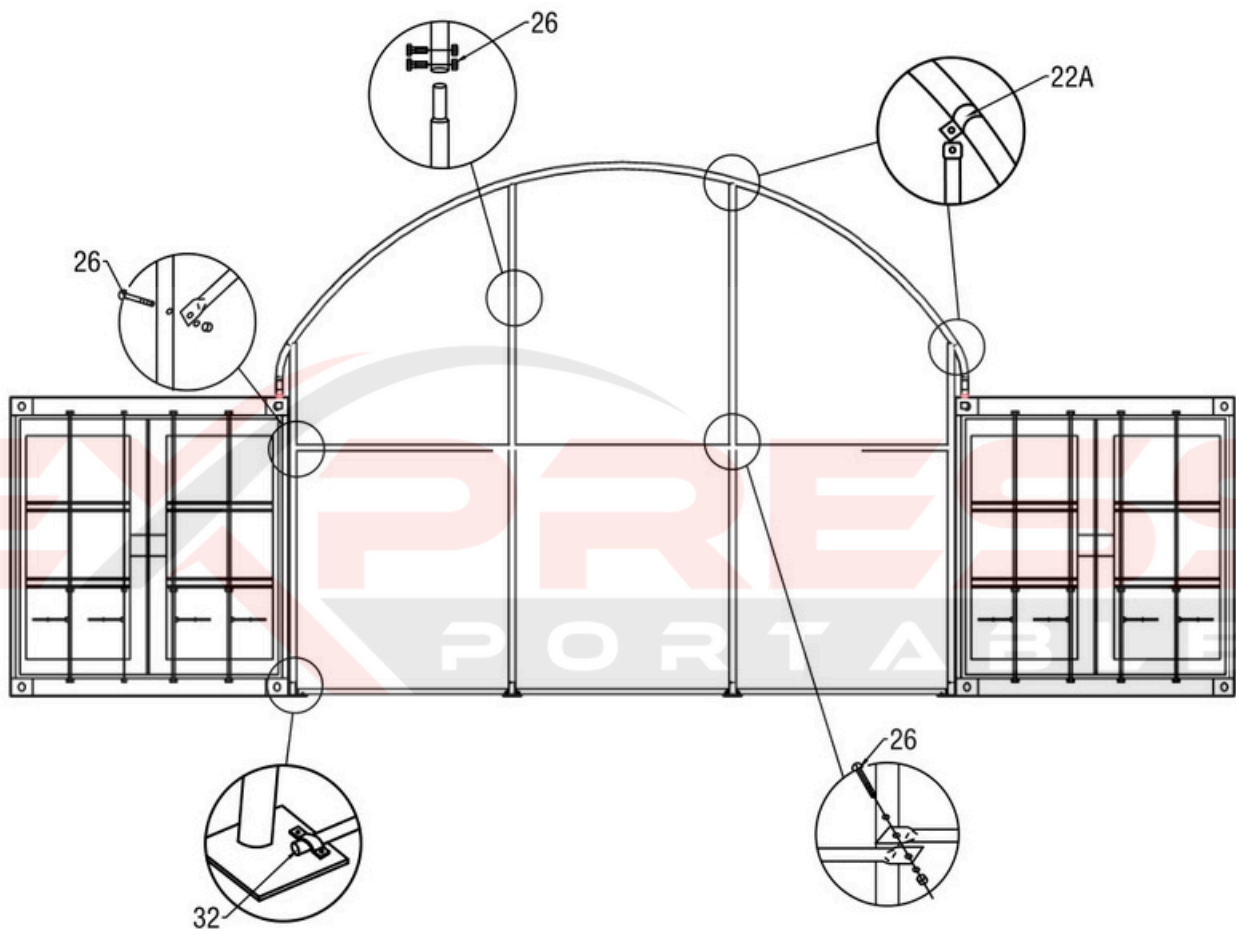
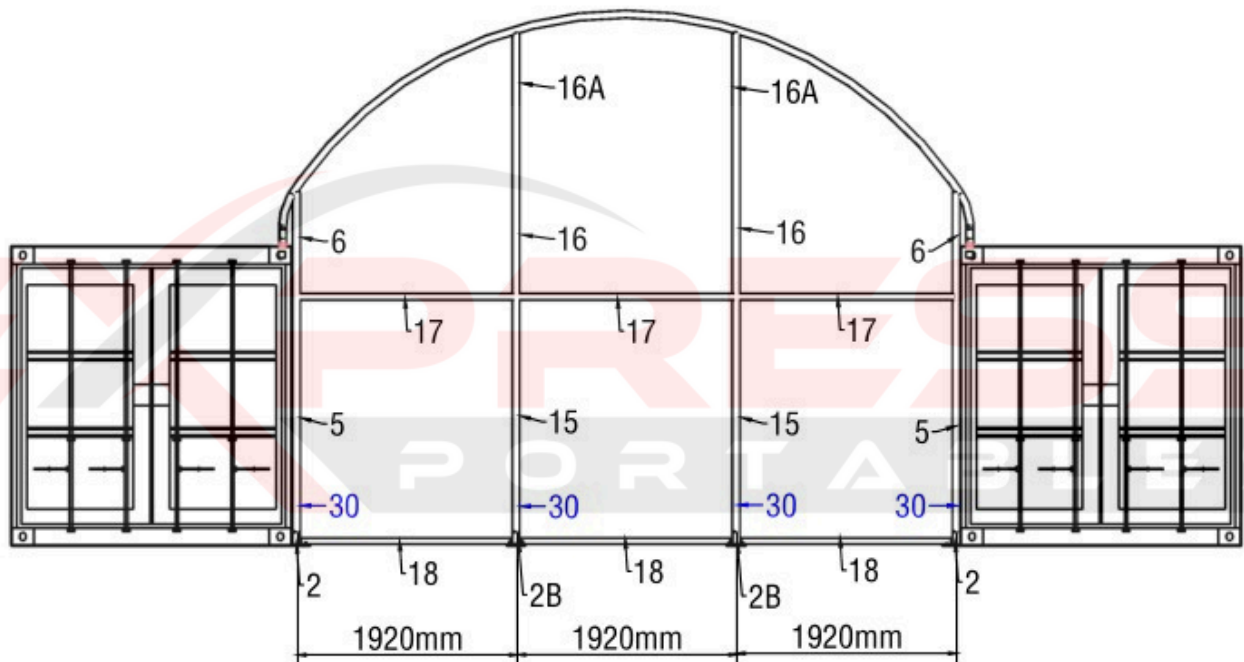

According to above Figure to find out all spare parts for back wall, connect them together by use screw, make sure the spacing. There are stake pegs for base plates.

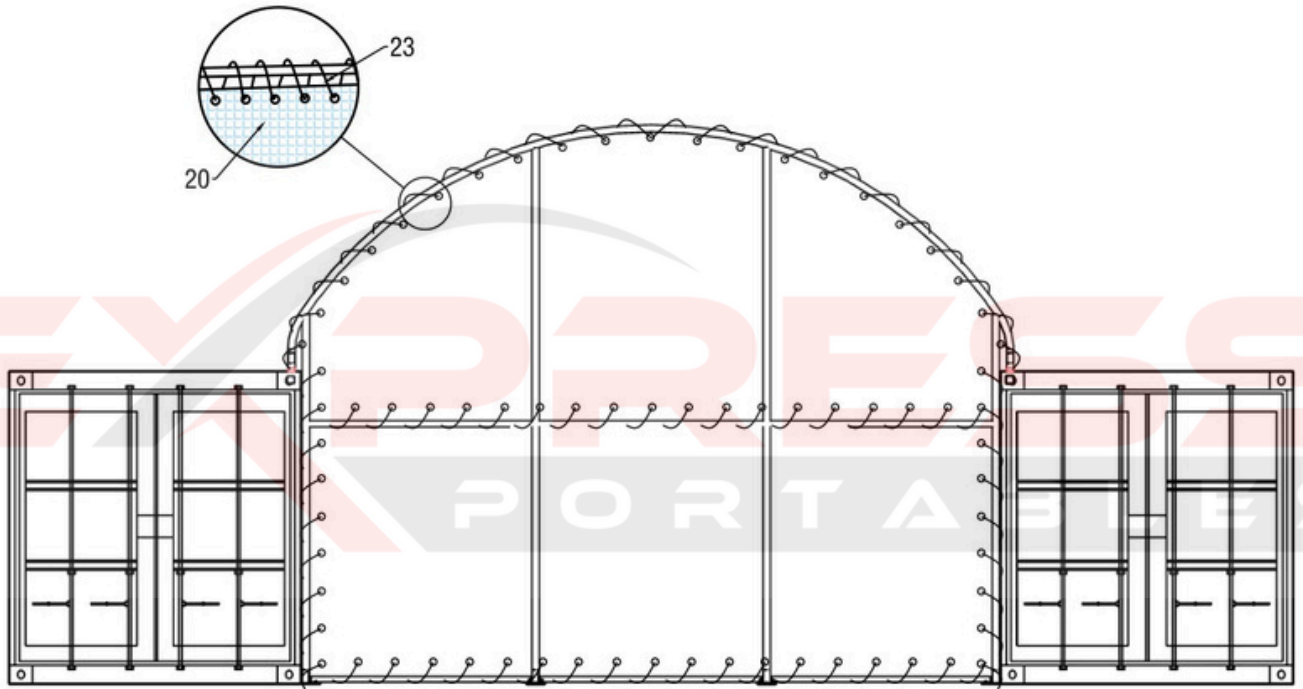

Find out the back cover(No.20), use ropes(No.23) to tie it to the back wall.  
Adjust and tighten them once per month after assembly to make sure they work perfect.